



## **NOTICE AND AGENDA**

**NOTICE IS HEREBY GIVEN  
THAT A REGULAR VILLAGE BOARD MEETING**

**WILL BE HELD ON**

**June 18, 2019**

**7:00 PM**

**Location: Oswego Village Hall**

---

- A. CALL TO ORDER AND PLEDGE OF ALLEGIANCE TO THE FLAG OF THE UNITED STATES OF AMERICA**
  
- B. ROLL CALL**
  
- C. CONSIDERATION OF AND POSSIBLE ACTIONS ON ANY REQUESTS FOR ELECTRONIC PARTICIPATION IN MEETING**
  
- D. RECOGNITIONS/APPOINTMENTS**

D.1. Employee Service Awards

- a. Cassandra Catberro- 5 Years of Service (Police Department)
- b. Jordan Lombardi- 5 Years of Service (Police Department)
- c. Kenneth Foote- 10 Years of Service (Police Department)
- d. Kelly Garcia- 15 Years of Service (Police Department)
- e. Denise Lawrence- 15 Years of Service (Police Department)
- f. Michael Gunter- 20 Years of Service (Public Works Department)
- g. Scott Hart- 20 Years of Service (Police Department)

Posted: \_\_\_\_\_  
Date: \_\_\_\_\_  
Time: \_\_\_\_\_  
Place: \_\_\_\_\_  
Initials: \_\_\_\_\_

Tina Touchette  
Village Clerk

D.2. Character Counts Awards

[Character Counts June 2019.pdf](#)

D.3. Police Commission Board:

- a) Re-appoint Ron Elvin for a Term to Expire April 30, 2022.

**E. PUBLIC FORUM**

**F. STAFF REPORTS**

**G. CONSENT AGENDA**

G.1. May 28, 2019 Special Committee of the Whole Minutes

[5-28-19 Spcl COTW.docx](#)

G.2. May 28, 2019 Special Village Board Minutes

[5-28-19 SpclVB.docx](#)

G.3. May 28, 2019 Closed Session Minutes (Approve and Release)

G.4. Resolution Authorizing Release of Certain Closed Session Minutes

[Memo-Release of Closed Session Minutes June 2019.docx](#)  
[19-R- Release Certain Closed Session Minutes.docx](#)

G.5. Resolution Authorizing the Destruction of Audio and Video Recordings of Closed Meeting Sessions Where More than 18 Months Have Elapsed.

[Memo-Destruction of Audio and Video Recordings of Closed Session Meetings.docx](#)  
[19-R- Destruction of Audio and Video Recordings.docx](#)

G.6. Resolution Approving the Oswego High School homecoming Parade and Temporary Closure of US Highway 34 and IL Route 71.

[Memo-OHS Homecoming Parade 2019.docx](#)  
[19-R- OHS Homecoming Parade.docx](#)  
[2019 Map\\_OHS Homecoming Parade Route.pdf](#)

- G.7. Resolution Authorizing the Execution of a Memorandum of Understanding Between the Oswego Police Department and the City of Aurora Police Department Regarding Use of the Aurora Police Department National Integrated Ballistic Information Network System.

[MOU - APD NIBN System - Memo - 6-18-19.docx](#)  
[MOU - APD NIBN System - Resolution - 6-18-19.docx](#)  
[NIBIN Intergovernmental Agreement - Exhibit A - 6-18-19.pdf](#)

- G.8. Resolution Designating Depositories and Signors for Village Banking Services and Accounts.

[Authorized depositories and signers 2019.docx](#)  
[Resolution Designated Depositories 2019.docx](#)

- G.9. Approval of a Resolution Relating to Participation by Elected Officials in the Illinois Municipal Retirement Fund

[Elected Official IMRF memo 061819.docx](#)  
[IMRF Resolution 061819.pdf](#)

## **H. BILL LIST**

- H.1. Approve Bill List Dated June 4, 2019 in the Amount of \$551,171.01 and Approve Bill List Dated June 18, 2019 in the Amount of \$939,624.05.

[6-4-19 Bill List.pdf](#)  
[6-18-19 Bill List.pdf](#)

## **I. OLD BUSINESS**

## J. NEW BUSINESS

- J.1. Ordinance Granting an Amendment to the Special Use Permit for Oswego Township to Allow for a Public Service Use Maintenance Garage Located at 1150 Route 25.

[1039.19 Oswego Township Garage Special Usse VB Memo \(VB 6-18-19\).docx](#)  
[Township Ordinance.docx](#)  
[Exhibit A Legal Description.docx](#)  
[Exhibit B Location Map.pdf](#)  
[Exhibit C Site Plan.pdf](#)  
[1039.19 Oswego Township Garage pc.061319.docx](#)

- J.2. 2019 Road Maintenance Project

- a. Supplemental Resolution for Maintenance Under the Illinois Highway Code in the Amount of \$99,600.00 of Motor Fuel Tax Funds in Fiscal Year 2020  
b. Resolution Authorizing the Execution of a Contract with D Construction, Coal City, IL in the Amount of \$828,722.62 for Maintenance of Various Streets

[jh061819.pbot 2019 MFTApprove construction contract.docx](#)  
[Recommendation Letter with Bid Tab from HR Green.pdf](#)  
[Supplemental Resolution for Maintenance Under the Illinois Highway Code - BLR14220 - Oswego 2019.pdf](#)  
[19-R- Authorizing Contract with D Construction.docx](#)  
[Exhibit A - 2019 Road Resurface Project Contract.pdf](#)

- J.3. Resolution Authorizing the Execution of a Four (4) Year Contract with Busted Knuckles Landscape, Sheridan, IL, for Tree Removal Services for Various Areas Throughout the Village.

[Tree Removal Services Contract Award Agenda Memo 061819.docxDDSRev.docx](#)  
[Exhibit B - Tree Services Bid Tab 041219.pdf](#)  
[19-R- Resolution Authorizing the Execution of a Four Year Contract with Busted Knuckles Landscape Sheridan IL for Tree Removal Services For Various Area.docx](#)  
[Exhibit A - Busted Knuckles Landscaping, LLC Signed Contract Packet.pdf](#)

- J.4. Resolution Authorizing the Execution of a Professional Engineering Services Contract with Christopher B. Burke Engineering Ltd. in an Amount of \$94,500.00 for a Traffic Study of Washington Street

[jh061819.pbot traffic study washington street.pdf](#)  
[19-R- Authorizing Contract with CBBEL for Traffic Study.docx](#)  
[Exhibit A - CBBEL PSA.pdf](#)

- J.5. Staffing Discussion

- a) Resolution Modifying Authorized Staffing from the FY2020 Budget (Part-time Administrative Assistant and Sergeant)

- b) Resolution Adopting Revised Fiscal Year 2020 Salary Ranges (Part-time Administrative Assistant)

[061819\\_Staffing\\_Discussion.docx](#)[DDSRev.docx](#)  
[Salary Ranges FY20 Revised 061819.pdf](#)  
[Organization Chart 2018v2 CPATCPAT2 \(002\).pdf](#)  
[Resolution Admin Assistant and Sergeant 061819.docx](#)  
[Resolution Revising Salary Ranges Admin Assist.docx](#)

**K. PRESIDENT’S REPORT**

**L. TRUSTEE REPORTS**

**M. CLOSED SESSION**

M.1.

- a. Pending and Probable Litigation [5 ILCS 120/2(c)(11)]
- b. Appointment, Employment, Compensation, Discipline, Performance, or Dismissal of Personnel [5 ILCS 120/2(c)(1)]
- c. Collective Bargaining, Collective Negotiating Matters, Deliberations Concerning Salary Schedules [5 ILCS 120/2(c)(2)]
- d. Sale, Lease, and/or Acquisition of Property [5 ILCS 120/2(c)(5) & (6)]
- e. Security Procedures and the Use of Personnel and Equipment to Respond to an Actual, Threatened, or a Reasonably Potential Danger to the Safety of Employees, Staff, the Public, or Public Property [5 ILCS 120/2(c)(8)]

**N. POSSIBLE ACTION OF CLOSED SESSION ITEMS INCLUDING:**

**O. CALENDAR UPDATE**

O.1. Calendar Update

[Calendar\\_Update.docx](#)

**P. ADJOURNMENT**



The Village of Oswego is pleased to announce this quarter's Character Counts Award winners!

These awards are presented to Youth, Teens, Adults and Organizations that have exhibited and/ or best exemplify one of the six pillars of Character – Trustworthiness, Respect, Responsibility, Fairness, Caring and Citizenship. They are recognized tonight for making our community a better place to live.

The award of \_\_\_\_\_ is presented to \_\_\_\_\_.

This \_\_\_\_\_ was nominated by \_\_\_\_\_ for:

The award of \_\_\_\_\_ is presented to \_\_\_\_\_.

This \_\_\_\_\_ was nominated by \_\_\_\_\_ for:

The award of \_\_\_\_\_ is presented to \_\_\_\_\_.

This \_\_\_\_\_ was nominated by \_\_\_\_\_ for:

The award of \_\_\_\_\_ is presented to \_\_\_\_\_.

This \_\_\_\_\_ was nominated by \_\_\_\_\_ for:

The award of \_\_\_\_\_ is presented to \_\_\_\_\_.

This \_\_\_\_\_ was nominated by \_\_\_\_\_ for:

**MINUTES OF A SPECIAL COMMITTEE OF THE WHOLE MEETING  
OSWEGO VILLAGE PRESIDENT AND BOARD OF TRUSTEES  
OSWEGO VILLAGE HALL  
100 PARKERS MILL, OSWEGO, ILLINOIS  
May 28, 2019**

**CALL TO ORDER**

President Troy Parlier called the meeting to order at 6:01 p.m.

**ROLL CALL**

Physically Present: President Troy Parlier and Trustees James Marter, Terry Olson, Pam Parr, Luis Perez, Judy Sollinger and Brian Thomas.

Staff Present: Dan Di Santo, Village Administrator; Christina Burns, AVA/HR Director; Tina Touchette, Village Clerk; Jeff Burgner, Police Chief; Mark Horton, Finance Director; Rod Zenner, Community Development Director; Corinna Cole, Economic Development Director; Jenette Sturges, Community Engagement Coordinator, Marketing; Carri Parker, Purchasing Manager; Joe Renzetti, IT Manager; and Karl Ottosen, Village Attorney.

**CONSIDERATION OF AND POSSIBLE ACTIONS ON-ANY REQUESTS FOR ELECTRONIC PARTICIPATION IN MEETING**

There was no one who participated electronically.

**PUBLIC FORUM**

Public Forum was opened at 6:01 p.m. There was no one who requested to speak; the Public Forum was closed at 6:01 p.m.

**OLD BUSINESS**

There was no Old Business.

**NEW BUSINESS**

There was no New Business.

**CLOSED SESSION**

A motion was made by Trustee Perez and seconded by Trustee Sollinger to enter into Closed Session for the purposes of discussing the following:

- a. Pending and Probable Litigation [5 ILCS 120/2(c)(11)]
- b. Appointment, Employment, Compensation, Discipline, Performance, or Dismissal of Personnel [5 ILCS 120/2(c)(1)]
- c. Collective Bargaining, Collective Negotiating Matters, Deliberations Concerning Salary Schedules [5 ILCS 120/2(c)(2)]

Aye: James Marter II  
Pam Parr  
Judy Sollinger

Terry Olson  
Luis Perez  
Brian Thomas

Nay: None

The motion was declared carried by a roll call vote with six (6) aye votes and zero (0) nay votes.

The Board adjourned to Closed Session at 6:02 p.m.

The Board returned to open session at 7:03 p.m.; all remaining members still present.

**ADJOURNMENT**

The meeting adjourned at 7:03 p.m.



**MINUTES OF A SPECIAL MEETING  
OSWEGO VILLAGE PRESIDENT AND BOARD OF TRUSTEES  
OSWEGO VILLAGE HALL  
100 PARKERS MILL, OSWEGO, ILLINOIS  
May 28, 2019**

**CALL TO ORDER AND PLEDGE OF ALLEGIANCE**

President Troy Parlier called the meeting to order at 7:03 p.m. and led the Pledge of Allegiance to the Flag of the United States of America.

**ROLL CALL**

Physically Present: President Troy Parlier and Trustees James Marter, Terry Olson, Pam Parr, Luis Perez, Judy Sollinger and Brian Thomas.

Staff Present: Dan Di Santo, Village Administrator; Christina Burns, AVA/HR Director; Tina Touchette, Village Clerk; Jeff Burgner, Police Chief; Jennifer Hughes, Public Works Director; Mark Horton, Finance Director; Rod Zenner, Community Development Director; Corinna Cole, Economic Development Director; Jenette Sturges, Community Engagement Coordinator, Marketing; Carri Parker, Purchasing Manager; Joe Renzetti, IT Manager; Tim Zasada, Asst. Public Works Director Utilities; and Karl Ottosen, Village Attorney.

**CONSIDERATION OF AND POSSIBLE ACTIONS ON-ANY REQUESTS FOR ELECTRONIC PARTICIPATION IN MEETING**

There was no one who participated electronically.

**RECOGNITIONS/APPOINTMENTS**

D.1. Adjudication:

- a) Re-appoint Carlo Colosimo for a Term to Expire April 30, 2020.
- b) Re-appoint Linda Salfisberg for a Term to Expire April 30, 2020.

Cultural Arts:

- a) Re-appoint Shannon Greene Robb for a Term to Expire April 30, 2022.
- b) Re-appoint Rachelle Stoller for a Term to Expire April 30, 2022.
- c) Re-appoint Tamzin Ritchie for a Term to Expire April 30, 2022.

Economic Development:

- a) Re-appoint Brian Caldwell for a Term to Expire April 30, 2022.
- b) Re-appoint Diane Nyhammer for a Term to Expire April 30, 2022.
- c) Re-appoint Terry Anderson for a Term to Expire April 30, 2022.
- d) Re-appoint Lisa Wentzell for a Term to Expire April 30, 2022.

Historic Preservation:

- a) Re-appoint John Brenneman for a Term to Expire April 30, 2022.

Police Pension Board:

- a) Re-appoint Mark Horton for a Term to Expire April 30, 2021.

President Parlier read the re-appointments and requested a motion to approve.

A motion was made by Trustee Perez and seconded by Trustee Olson to approve the re-appointments.

Aye: James Marter II                      Terry Olson  
Pam Parr                                      Luis Perez  
Judy Sollinger                              Brian Thomas

Nay: None

The motion was declared carried by a roll call vote with six (6) aye votes and zero (0) nay votes.

**PUBLIC FORUM**

Public Forum was opened at 7:06 p.m. There was no one who requested to speak; the Public Forum was closed at 7:06 p.m.

**STAFF REPORTS**

Administrator Di Santo-

The June 4, 2019 Board meetings are canceled. Next meetings will be held on June 18, 2019.

Last week, him, President Parlier and Director Cole attended ICSC in Las Vegas. It was mostly positive; a lot of optimism; quite productive; Director Cole went very well prepared; Board will hear more about it at a future meeting. He thanked President Parlier for attending. President Parlier thanked Director Cole; it was a good trip.

Staff is looking at expanding shared services; will be holding a shared services summit with other taxing bodies to see if there are opportunities for savings. Summit to be held some time in June.

Director Hughes-

Village sustained a significant rain, wind and hail storm yesterday; caused flash flooding, catch basins to close and a number of trees down; Windcrest through the old part of town was also affected; a tree landed on a car with a family inside the car; Public Works personnel were able to cut the tree off the car before emergency vehicles arrived; debris on the roads; personnel are working to open driveways and sidewalks; street sweeping starts tomorrow; pulling debris out of inlets; will take some time to get through Village for clean-up; will be looking to other agencies for help; brush pick-up will start next week in Zone A; Zone B will start the second week in June; crews are working 5:00 a.m.-6:00p.m.

**CONSENT AGENDA**

- G.1. May 7, 2019 Special Village Board Minutes
- G.2. Ordinance Amending Title 1 Chapter 7 Section 12 (G); Rules of Order. (First Read of Ordinance, Waiver of Second Read) **Ordinance No. 19-33**
- G.3. Ordinance Authorizing the Disposal of Surplus Property Owned by the Village of Oswego. (First Read of Ordinance; Waiver of Second Read). **Ordinance No. 19-34**

A motion was made by Trustee Perez and seconded by Trustee Thomas to approve the Consent Agenda; Approving the May 7, 2019 Special Village Board Minutes; and approving the following ordinances:

**Ordinance No. 19-33;** Ordinance Amending Title 1 Chapter 7 Section 12 (G); Rules of Order. (First Read of Ordinance, Waiver of Second Read)

**Ordinance No. 19-34;** Ordinance Authorizing the Disposal of Surplus Property Owned by the Village of Oswego. (First Read of Ordinance; Waiver of Second Read)

Aye: James Marter II                      Terry Olson  
Pam Parr                                      Luis Perez  
Judy Sollinger                              Brian Thomas

The motion was declared carried by an omnibus roll call vote with six (6) aye votes and zero (0) nay votes.

**BILL LIST**

H.1. Approve Bill List Dated May 28, 2019 in the Amount of \$1,449,371.65.

A motion was made by Trustee Perez and seconded by Trustee Parr to approve the Bill List Dated May 28, 2019 in the Amount of \$1,449,371.65.

Aye: James Marter II	Terry Olson
Pam Parr	Luis Perez
Judy Sollinger	Brian Thomas

The motion was declared carried by a roll call vote with six (6) aye votes and zero (0) nay votes.

**OLD BUSINESS**

There was no Old Business.

**NEW BUSINESS**

J.1. Resolution Authorizing the Execution of an Agreement with HR Green, Inc. Consulting Engineers for the Brock Ct., Sedgwick Ct., and Faro Ct. Water Main Replacement Project in an Amount Not to Exceed \$30,367.00. **Resolution No. 19-R-42**

Asst. Public Works Director Zasada addressed the Board regarding an agreement for water main replacement. The water main that feeds Brock Ct. and Sedgwick Ct. is a 2-inch ductile iron water main with no fire hydrant for flushing. The 2-inch water main is no longer manufactured, and parts are not available for repairs. If a major failure occurs, the Village would not be able to deliver potable water to the residences. The proposed 6-inch water main, with a length of 220 feet, is planned for Sedgwick Ct. and 190 feet for Brock Ct. Faro Ct. has experienced numerous failures in the past years and needs to be replaced. It is recommended that 350 feet of 6-inch water main will be needed to replace the deteriorating water main. This project is tentatively scheduled for construction in Fall of 2019.

Staff selected HR Green, Inc. Consulting Engineers to complete the design phase of the project, assist with the bid process and construction oversight. HR Green, Inc. has completed various projects in past years and has been outstanding in performance and professionalism in their industry. The Village currently has an existing General Consultation Services Agreement. The replacement of the water mains is vital in providing a reliable water source to the residence of the Village. If the repairs are not completed, the mains will fail and will be problematic thus causing a long hardship on the residence.

Staff recommended moving forward with the agreement with HR Green, Inc. for the design phase of Brock Ct. Sedgwick Ct. and Faro Ct. water main replacement. Total estimated cost of repairs is projected not to exceed \$330,000 and will be provided through the Water and Sewer Capital Fund. There was no further discussion.

A motion was made by Trustee Marter II and seconded by Trustee Olson to approve a Resolution Authorizing the Execution of an Agreement with HR Green, Inc. Consulting Engineers for the Brock Ct., Sedgwick Ct., and Faro Ct. Water Main Replacement Project in an Amount Not to Exceed \$30,367.00

Aye: James Marter II	Terry Olson
Pam Parr	Luis Perez

Judy Sollinger

Brian Thomas

The motion was declared carried by a roll call vote with six (6) aye votes and zero (0) nay votes.

J.2. Resolution Authorizing the Execution of an Agreement with RJN Group, Inc. Professional Engineers for the Management Services of the Sanitary Sewer Inspection Project in an Amount Not to Exceed \$34,925.00. **Resolution No. 19-R-43**

Asst. Public Works Director Zasada addressed the Board regarding an agreement for sanitary sewer inspections. The Village sanitary sewer inspection, cleaning, and lining program is a proactive program which prioritizes and identifies corrective actions needed including debris removal, grease or root abatement, repair and replacement recommendation prior to sanitary overflows and backups. Sanitary sewers where known inflow and infiltration problems occur are televised to determine whether pipes can be lined to eliminate these problems. In Spring 2013, the Village and Fox Metro Water Reclamation District signed an intergovernmental agreement allowing the Village to utilize Fox Metro's contractor, Visu-sewer, to keep costs down. RJN Group, Inc. Professional Engineers is a nationally recognized leader in sewer collection systems and specializes in inspecting, studying, analyzing, and designing sewer systems. In their 44-year history, they have evaluated over a quarter-billion feet of sewers. By utilizing this group to manage the televising, cleaning and lining of the sanitary pipes; the root foaming costs will be eliminated, and inflow and infiltration will be removed. This program is required by the Illinois Environmental Protection Agency.

Staff selected RJN Group, Inc. Professional Engineers to complete the consultation and management of the project and to assist staff with the completion of the inspection of the sanitary sewers in the downtown and older sections of the Village. There was no competitive bidding process as per the Village Purchasing Code, Title 1-19-7 (A)(1) Bid Exemptions, RJN Group, Inc. Professional Engineers are exempt from the competitive bidding requirement as they are a professional services company with individuals or firms holding a professional license or possessing a high degree of professional skill or expertise where the ability and fitness of the individual or organization plays an important part in the performance of the contract. The sanitary sewer inspections would be completed over a multiple year time period. Staff would focus on critical areas in need of debris removal, grease or root abatement, repair or replacement recommendations. Crews will have accurate maps when responding to sewer backups, making response quicker and decisions more accurate. Postponing the project will result in the Village incurring additional costs pumping stormwater that enters the sanitary sewers at the lift stations.

Staff recommended the approval of the agreement with RJN Group, Inc. Professional Engineers to proceed with the management of the sanitary sewer cleaning, inspection and lining of the Village sanitary sewers. Total estimated cost of repairs is \$160,000 and will be provided through the Water and Sewer Capital Fund.

Board and staff discussion focused on what root foaming is; root foaming is a method to get rid of roots; foaming kills the roots instead of cutting the roots out and lining. There was no further discussion.

A motion was made by Trustee Sollinger and seconded by Trustee Thomas to approve a Resolution Authorizing the Execution of an Agreement with RJN Group, Inc. Professional Engineers for the Management Services of the Sanitary Sewer Inspection Project in an Amount Not to Exceed \$34,925.00.

Aye: James Marter II  
Pam Parr

Terry Olson  
Luis Perez

Judy Sollinger

Brian Thomas

The motion was declared carried by a roll call vote with six (6) aye votes and zero (0) nay votes.

J.3. Resolution Authorizing the Purchase of a Four-Column Portable Vehicle Lift from Napa Auto Parts in the Amount of \$42,000. **Resolution No. 19-R-44**

Manager Parker addressed the Board regarding the purchase of portable lifts. Currently, the public works vehicle maintenance garage uses two lifts (inground and a two-post style). Unfortunately, the company who manufactures the inground lift is no longer in business and repair parts have been difficult to locate. The gross vehicle weight rating of Village owned Class 6-8 vehicles averages 40,000 lbs. The two-post lift is rated at 18,000 lbs. and does not meet the standards to lift the weight of a larger public works vehicle. The four-column portable lift will be the primary lifting source for the larger vehicles with a max weight rating at 76,000 lbs. and will allow the vehicle maintenance and service of these vehicles. The inground lifts are difficult to use on the large vehicles as both axles must be lifted independently, limiting access to vehicle components due to the placement of the lifting surfaces.

With the safety and mechanical issues the existing in-ground lift is experiencing, staff is requesting to purchase a new four-column portable lift through Napa Auto Parts by using a cooperative purchasing agreement with Sourcewell. This lift will allow the mechanics to work on the larger trucks more efficiently and safely. These lifts are also portable, resulting in better mobility if repairs are needed elsewhere instead of inside the maintenance garage. Additionally, the column lifts have built-in safety features including the Lock Light System. This system allows mechanics to verify the lift is in the locked position and is safe to work beneath the vehicle.

This item was listed in the FY2020 Capital Improvement Plan and the Village Board approved the CIP on April 16, 2019. There was no further discussion.

A motion was made by Trustee Parr and seconded by Trustee Olson to approve a Resolution Authorizing the Purchase of a Four-Column Portable Vehicle Lift from Napa Auto Parts in the Amount of \$42,000.

Aye: James Marter II  
Pam Parr  
Judy Sollinger

Terry Olson  
Luis Perez  
Brian Thomas

The motion was declared carried by a roll call vote with six (6) aye votes and zero (0) nay votes.

**PRESIDENT'S REPORT**

K.1. Proclamation- Flag Day, June 14, 2019

President Parlier recognized Flag Day, June 14, 2019.

Very proud of the community after the storms that came through yesterday; asked that community assist with cleaning grates and helping others; outstanding job by Public Works and Director Hughes.

**TRUSTEE REPORTS**

Trustee Thomas- thanked Public Works and Director Hughes for their work; terrible 2-3 weeks; successful trip to Vegas; see great things going forward; looking forward to the summit.

Trustee Perez- thanked the Public Works team and Director Hughes; good luck and keep the Board posted.

Trustee Marter II- thanked all for their hard work.

Trustee Parr- thank you to Public Works; great job in Vegas; thanked President Parlier for representing the Village in Vegas.

Trustee Olson- attended the KenCom meeting as an alternate; thanked Public Works and Director Hughes for helping after the storm incident. Director Hughes noted that Trustee Olson and Manager Hoover were out helping to clear the streets.

**CLOSED SESSION**

There was no Closed Session held.

**ADJOURNMENT**

A motion was made by Trustee Perez and seconded by Trustee Sollinger to adjourn the meeting; upon a voice vote with all remaining members present voting aye, the meeting was adjourned at 7:26 p.m.

Tina Touchette  
Village Clerk

DRAFT

**AGENDA ITEM**

**MEETING TYPE:** Village Board  
**MEETING DATE:** June 18, 2019  
**SUBJECT:** Closed Session Minutes Release

**ACTION REQUESTED:**  
 Consideration to approve a resolution authorizing the release of certain closed session minutes.

**BOARD/COMMISSION REVIEW:**  
 N/A

**ACTION PREVIOUSLY TAKEN:**

Date of Action	Meeting Type	Action Taken
N/A	N/A	N/A

**DEPARTMENT:** Clerks Office  
**SUBMITTED BY:** Tina Touchette, Village Clerk

**FISCAL IMPACT:**  
 N/A

**BACKGROUND:**  
 N/A

**DISCUSSION:**  
 The Village President and Board of Trustees are required to review Closed Session minutes every six (6) months for release. Village Attorney Ottosen, Village Attorney Greg Jones and the Village Clerk reviewed the Closed Session minutes and have proposed certain minutes for the Village President and Board of Trustees to review and determine if they can be released at this time.

**RECOMMENDATION:**  
 Staff is recommending the approval of a resolution authorizing the release of certain closed session minutes.

**ATTACHMENTS:**

- Resolution

**RESOLUTION NO. 19 - R - \_\_\_\_**

---

**A RESOLUTION AUTHORIZING RELEASE  
OF CERTAIN CLOSED SESSION MINUTES**

---

**WHEREAS**, the Village of Oswego (“Village”) has a population of more than 25,000 and is therefore a “Home Rule Unit” under the 1970 Illinois Constitution; and

**WHEREAS**, the Illinois Constitution of 1970 provides that a Home Rule Unit may exercise any power and perform any function pertaining to its government and affairs, including but not limited to the power to regulate for the protection of the public health, safety, morals and welfare; to license, to tax; and to incur debt; and

**WHEREAS**, it is in the best interest of the Village of Oswego to approve the release of certain closed session minutes, and parts of certain closed session minutes, which no longer require confidentiality as set forth in “Exhibit A”.

**NOW, THEREFORE, BE IT RESOLVED BY THE PRESIDENT AND BOARD OF  
TRUSTEES OF THE VILLAGE OF OSWEGO, KENDALL AND WILL COUNTIES, ILLINOIS,**  
as follows:

**SECTION 1. INCORPORATION OF RECITAL**

That the recitals set forth above are incorporated here by reference.

**SECTION 2. RELEASE OF CLOSED SESSION MINUTES**

Closed Sessions Minutes as set forth on Exhibit “A” attached herewith are hereby released. The Village Clerk is hereby authorized and directed to make said minutes available for inspection and copying in accordance with the standing procedures of the Clerk's Office.

**SECTION 3. REPEALER**

All resolutions or parts of resolutions in conflict with any of the provisions of this resolution shall be, and the same hereby repealed to the extent of any conflict.

**SECTION 4. SEVERABILITY**

This Resolution and every provision thereof shall be considered severable. If any section, paragraph, clause or provision of this Resolution is declared by a court of law to be invalid or



unconstitutional, the invalidity or unconstitutionality thereof shall not affect the validity of any other provisions of this Resolution.

**SECTION 5. EFFECTIVE DATE**

This Resolution shall be in full force and effect from and after its passage.

**PASSED** by the Board of Trustees of the Village of Oswego, Kendall and Will Counties, Illinois this 18<sup>th</sup> day of June 2019.

JAMES MARTER	_____	LUIS PEREZ	_____
TERRY OLSON	_____	JUDY SOLLINGER	_____
PAM PARR	_____	BRIAN THOMAS	_____

**APPROVED** by me, Troy Parlier, as President of the Village of Oswego, Kendall and Will Counties, Illinois this 18<sup>th</sup> day of June 2019.

\_\_\_\_\_  
TROY PARLIER, VILLAGE PRESIDENT

\_\_\_\_\_  
Tina Touchette, Village Clerk

**EXHIBIT A**

June 7, 2011	Release Remaining
February 19, 2013	Release Remaining
March 19, 2013	Release Remaining
May 7, 2013	Release
June 4, 2013	Release Remaining
June 18, 2013	Partial
March 15, 2016	Release
April 5, 2016	Release Remaining
January 17, 2017	Release Remaining
February 7, 2017	Partial
February 21, 2017	Partial
March 7, 2017	Partial
November 21, 2017	Partial
January 16, 2018	Partial
March 19, 2018	Release Remaining
April 17, 2018	Release
May 15, 2018	Partial
June 5, 2018	Partial
June 19, 2018	Release Remaining
July 17, 2018	Partial
August 7, 2018	Partial
September 4, 2018	Partial
October 16, 2018	Release
February 19, 2019	Release
April 9, 2019	Release

STATE OF ILLINOIS     )  
  )  
COUNTY OF KENDALL    )        SS

**CLERK'S CERTIFICATE**  
**(RESOLUTION)**

I, Tina Touchette, the duly qualified and acting Village Clerk of the Village of Oswego, Kendall and Will Counties, Illinois, do hereby certify that I am the keeper of its books and records and that the attached hereto is a true and correct copy of a Resolution entitled:

**A RESOLUTION AUTHORIZING RELEASE OF CERTAIN CLOSED SESSION MINUTES**

which Resolution was duly adopted by said Board of Trustees at a meeting held on the 18<sup>th</sup> day of June 2019, and thereafter approved by the Village President on the 18<sup>th</sup> day of June 2019.

I do further certify, in my official capacity, that a quorum of said Board of Trustees was present at said meeting and that the Board complied with all requirements of the Illinois Open Meetings Act.

IN WITNESS WHEREOF, I have hereunto set my hand this \_\_\_\_day of June 2019.

\_\_\_\_\_  
Tina Touchette, Village Clerk  
Village of Oswego

(Seal)

**AGENDA ITEM**

**MEETING TYPE:** Village Board

**MEETING DATE:** July 16, 2019

**SUBJECT:** Destruction of Audio and Video Recordings of Closed Session Meetings

**ACTION REQUESTED:**

Consideration to approve a resolution authorizing the destruction of audio and video recording of closed session meetings more than 18 months.

**BOARD/COMMISSION REVIEW:**

N/A

**ACTION PREVIOUSLY TAKEN:**

Date of Action	Meeting Type	Action Taken
N/A	N/A	N/A

**DEPARTMENT:** Clerks Office

**SUBMITTED BY:** Tina Touchette, Village Clerk

**FISCAL IMPACT:**

N/A

**BACKGROUND:**

N/A

**DISCUSSION:**

The Open Meetings Act, 5 ILCS120/2.06 requires governmental bodies to audio or video record closed or executive session meetings. The Open Meetings Act permits governmental bodies to destroy the audio and video recordings of closed meetings without notification to or the approval of a Records Commission or the State Archivist of those closed sessions for which:

1. The corporate authorities of the Village have approved the minutes of the closed sessions as to accurate content, regardless of whether the minutes have been released for public review
2. More than eighteen (18) months have elapsed since the date of the closed session
3. There is no court order requiring the preservation of such recording
4. The corporate authorities of the Village have not passed a motion requiring the preservation of the verbatim recording of that meeting

The Village Clerk, or their designee, shall be responsible for the retention or destruction of the audio or video recordings of all closed meetings of the Village in accordance with the relevant Illinois Compiled Statutes and the direction of the corporate authorities.

**RECOMMENDATION:**

Staff is recommending the approval of a resolution authorizing the destruction of audio and video recording of closed session meetings more than 18 months

**ATTACHMENTS:**

- Resolution

**RESOLUTION NO. 19 - R - \_\_\_\_**

---

**A RESOLUTION AUTHORIZING THE DESTRUCTION OF AUDIO  
AND VIDEO RECORDINGS OF CLOSED MEETING SESSIONS  
WHERE MORE THAN 18 MONTHS HAVE ELAPSED**

---

**WHEREAS**, the Village of Oswego (“Village”) has a population of more than 25,000 and is therefore a “Home Rule Unit” under the 1970 Illinois Constitution; and

**WHEREAS**, the Illinois Constitution of 1970 provides that a Home Rule Unit may exercise any power and perform any function pertaining to its government and affairs, including but not limited to the power to regulate for the protection of the public health, safety, morals and welfare; to license, to tax; and to incur debt; and

**WHEREAS**, the Open Meetings Act, 5 ILCS120/2.06 requires governmental bodies to audio or video record their closed or executive session meetings; and

**WHEREAS**, this government body has complied with that requirement; and

**WHEREAS**, the corporate authorities of the Village of Oswego seek to establish procedures by which the Village can provide for the destruction of such recordings; and

**WHEREAS**, the Open Meetings Act permits governmental bodies to destroy the audio and video recordings of closed meetings without notification to or the approval of a Records Commission or the State Archivist of those closed sessions for which:

1. The corporate authorities of the Village have approved the minutes of the closed sessions as to accurate content, regardless of whether the minutes have been released for public review;
2. More than eighteen (18) months have elapsed since the date of the closed session;
3. There is no court order requiring the preservation of such recording; and
4. The corporate authorities of the Village have not passed a motion requiring the preservation of the verbatim recording of that meeting.

**NOW, THEREFORE, BE IT RESOLVED BY THE PRESIDENT AND BOARD OF TRUSTEES OF THE VILLAGE OF OSWEGO, KENDALL AND WILL COUNTIES, ILLINOIS,**  
as follows:

**SECTION 1.** The Village Clerk, or their designee, shall be responsible for the retention or destruction of the audio or video recordings of all closed meetings of the Village in accordance with the relevant Illinois Compiled Statutes and the direction of the corporate authorities.

**SECTION 2. DESTRUCTION OF RECORDINGS:**

The Village Clerk, or her designee, is hereby authorized to destroy the audio and video recordings of those closed sessions for which:

1. The corporate authorities of the Village have approved the minutes of the closed sessions as to accurate content, regardless of whether the minutes have been released for public review;
2. More than eighteen (18) months have elapsed since the date of the closed session;
3. There is no court order or direction from the Village Attorney requiring the preservation of such recording; and
4. The corporate authorities of the Village have not passed a motion requiring the preservation of the verbatim recording of that meeting.

**SECTION 3. INCORPORATION OF RECITAL**

That the recitals set forth above are incorporated here by reference.

**SECTION 3. REPEALER**

All Resolutions or parts of Resolutions in conflict with any of the provisions of this Resolution shall be, and the same hereby repealed to the extent of the conflict.

**SECTION 4. SEVERABILITY**

This Resolution and every provision thereof shall be considered severable. If any section, paragraph, clause or provision of this Resolution is declared by a court of law to be invalid or unconstitutional, the invalidity or unconstitutionality thereof shall not affect the validity of any other provisions of this Resolution.

**SECTION 5. EFFECTIVE DATE**

This Resolution shall be in full force and effect from and after its passage and approval in the manner provided by law

**PASSED** by the Board of Trustees of the Village of Oswego, Kendall and Will Counties, Illinois this \_\_ day of \_\_ 2019.

JAMES MARTER	_____	LUIS PEREZ	_____
TERRY OLSON	_____	JUDY SOLLINGER	_____
PAM PARR	_____	BRIAN THOMAS	_____

**APPROVED** by me, Troy Parlier, as President of the Village of Oswego, Kendall and Will Counties, Illinois this \_\_\_\_ day of \_\_\_\_ 2019.

---

TROY PARLIER, VILLAGE PRESIDENT

---

Tina Touchette, Village Clerk

DRAFT



STATE OF ILLINOIS     )  
  )  
COUNTY OF KENDALL    )     SS

**CLERK'S CERTIFICATE**  
**(RESOLUTION)**

I, Tina Touchette, the duly qualified and acting Village Clerk of the Village of Oswego, Kendall and Will Counties, Illinois, do hereby certify that I am the keeper of its books and records and that the attached hereto is a true and correct copy of a Resolution entitled:

**A RESOLUTION AUTHORIZING THE DESTRUCTION OF AUDIO AND VIDEO RECORDINGS OF CLOSED MEETING SESSIONS WHERE MORE THAN 18 MONTHS HAVE ELAPSED**

which Resolution was duly adopted by said Board of Trustees at a meeting held on the \_\_\_ day of \_\_\_\_\_ 2019, and thereafter approved by the Village President on the \_\_\_ day of \_\_\_\_\_ 2019.

I do further certify, in my official capacity, that a quorum of said Board of Trustees was present at said meeting and that the Board complied with all requirements of the Illinois Open Meetings Act.

IN WITNESS WHEREOF, I have hereunto set my hand this \_\_\_ day of \_\_\_\_\_ 2019.

\_\_\_\_\_  
Tina Touchette, Village Clerk  
Village of Oswego

(Seal)

DRAFT

**AGENDA ITEM**

**MEETING TYPE:** Village Board  
**MEETING DATE:** June 18, 2019  
**SUBJECT:** OHS Homecoming Parade

**ACTION REQUESTED:**

Consideration to Approve a Resolution Approving the Oswego High School Homecoming Parade and the Temporary Closure of US Highway 34 and IL Route 71.

**BOARD/COMMISSION REVIEW:**

N/A

**ACTION PREVIOUSLY TAKEN:**

Date of Action	Meeting Type	Action Taken
N/A	N/A	N/A

**DEPARTMENT:** Clerks Office

**SUBMITTED BY:** Tina Touchette

**FISCAL IMPACT:**

N/A

**BACKGROUND:**

N/A

**DISCUSSION:**

Oswego High School submitted a Special Event Permit application for the OHS Homecoming Parade to be held on Sunday, September 22, 2019. As part of this event, the parade will require temporary closure of both lanes of US Highway 34 at Jefferson Street and Main Street; and IL Route 71 between Oswego High School and Franklin Street. There will be no detour route and traffic may go through by the Oswego Police Department stopping the parade. IDOT permission to temporarily close a State Highway needs to be obtained.

This year’s event time needed to be moved to 3:00 pm versus 12:00 noon to allow for the Oswego Country Market to clear Main Street for the parade. In previous years, the parade was held after all scheduled Country Market events concluded for the year.

**RECOMMENDATION:**

Staff is recommending the approval of the resolution for the OHS Homecoming Parade to be held on Sunday, September 22, 2019.

**ATTACHMENTS:**

- Resolution
- Map

**RESOLUTION NO. 19 - R - \_\_**

---

**RESOLUTION APPROVING THE OSWEGO HIGH SCHOOL HOMECOMING PARADE AND TEMPORARY CLOSURE OF US HIGHWAY 34 AND IL ROUTE 71**

---

**WHEREAS**, the Village of Oswego (“Village”) has a population of more than 25,000 and is therefore a “Home Rule Unit” under the 1970 Illinois Constitution; and

**WHEREAS**, the Illinois Constitution of 1970 provides that a Home Rule Unit may exercise any power and perform any function pertaining to its government and affairs, including but not limited to the power to regulate for the protection of the public health, safety, morals and welfare; to license, to tax; and to incur debt; and

**WHEREAS**, Community Unit School District 308 is sponsoring a Homecoming Parade in the Village of Oswego, which constitutes a public purpose; and

**WHEREAS**, this parade will require the temporary closure of the intersection of IL Route 71 and Franklin Street; and the intersection of US HWY 34 at Jefferson Street; and the intersection of US HWY 34 (Washington Street) at Main Street; and

**WHEREAS**, Section 4-408 of the Illinois Highway Code authorizes the Department of Transportation to issue permits to local authorities to temporarily close portions of State Highways for such public purposes; and

**NOW THEREFORE, BE IT RESOLVED**, by the Village President and Board of Trustees of the Village of Oswego, Kendall and Will Counties, Illinois that permission to close the intersections of IL Route 71 and Franklin Street; US HWY 34 at Jefferson Street; and US HWY 34 (Washington Street) at Main Street as above designated, be requested of the Department of Transportation.

**BE IT FURTHER RESOLVED**, that this closure shall occur during the approximate time period between 2:30 p.m. and 4:00 p.m. on Sunday, September 22, 2019 with each intersection being closed no longer than fifteen (15) minutes at a time; and

**BE IT FURTHER RESOLVED**, that the Village of Oswego assumes full responsibility for the direction, protection, and regulation of the traffic during the time the parade is in effect; and

**BE IT FURTHER RESOLVED**, that police officers or authorized flaggers shall, at the expense of the Village of Oswego, be positioned at each end of the closed section and at other points (such as intersections) as may be necessary to assist in directing traffic; and

**BE IT FURTHER RESOLVED**, that police officers, flaggers, and officials shall permit emergency vehicles in emergency situations to pass through the closed area as swiftly as is safe for all concerned; and

**BE IT FURTHER RESOLVED**, that all debris shall be removed by the Village of Oswego prior to reopening the State Highways; and

**BE IT FURTHER RESOLVED**, that such signs, flags, barricades, etc., shall be used by the Village Oswego as may be approved by the Illinois Department of Transportation. These items shall be provided by the Village of Oswego; and

**BE IT FURTHER RESOLVED**, that the closure shall be marked according to the Illinois Manual on Uniform Traffic Control Devices; and

**BE IT FURTHER RESOLVED**, there shall be no detour route and traffic on IL Route 71 or US HWY 34; and

**BE IT FURTHER RESOLVED**, that an occasional break shall be made in the procession so that traffic may pass through. In any event, adequate provisions will be made for traffic on intersecting highways pursuant to conditions noted above; and

**BE IT FURTHER RESOLVED**, that to the fullest extent permitted by law, the Community Unit School District 308 shall be responsible for any and all injuries to persons or damages to property, and shall indemnify and hold harmless the Illinois Department of Transportation, its officers, employees and agents from any and all claims, lawsuits, actions, costs and fees (including reasonable attorneys' fees and expenses) of every nature or description, arising out of, resulting from or connected with the exercise of authority granted by the Department which is the subject of this resolution. The obligation is binding upon the Community Unit School District 308 regardless of whether or not such claim, damage, loss or expense

is caused in part by the act, omission or negligence of the Department or its officers, employees or agents;  
and

**BE IT FURTHER RESOLVED**, that the Community Unit School District 308 shall provide a comprehensive general liability insurance policy or an additional named insured endorsement in the minimum amount of \$1,000,000.00 per person and \$2,000,000.00 aggregate which has the Illinois Department of Transportation and the Village of Oswego, its officials, employees, and agents as insureds and which protects them from all claims arising from the requested road closing. A copy of said policy or endorsement will be provided to the Department and Village of Oswego before the road is closed; and

**BE IT FURTHER RESOLVED**, that a copy of this resolution be forwarded to the Department of Transportation to serve as a formal request for the permission sought in this resolution and to operate as part of the conditions of said permission; and

**BE IT FURTHER RESOLVED BY THE PRESIDENT AND BOARD OF TRUSTEES OF THE VILLAGE OF OSWEGO, KENDALL AND WILL COUNTIES, ILLINOIS**, as follows:

**SECTION 1. INCORPORATION OF RECITAL**

That the recitals set forth above are incorporated here by reference.

**SECTION 2. SUPPORT FOR TEMPORARY CLOSURE**

The Village President and Village Board of Trustees do hereby request that the Illinois Department of Transportation grant permission to close the above designated locations with such closure occurring between the hours of 2:30 p.m. to 4:00 p.m. on Sunday, September 22, 2019 with each intersection being closed no longer than fifteen (15) minutes at a time.

**SECTION 3. REPEALER**

All Resolutions or parts of Resolutions in conflict with any of the provisions of this Resolution shall be, and the same hereby repealed.

**SECTION 4. SEVERABILITY**

This Resolution and every provision thereof shall be considered severable. If any section, paragraph, clause or provision of this Resolution is declared by a court of law to be invalid or unconstitutional, the invalidity or unconstitutionality thereof shall not affect the validity of any other provisions of this Resolution.

**SECTION 5. EFFECTIVE DATE**

This Resolution shall be in full force and effect from and after its passage.

**PASSED** by the Board of Trustees of the Village of Oswego, Kendall and Will Counties, Illinois this 18<sup>th</sup> day of June 2019.

JAMES MARTER

\_\_\_\_\_

LUIS PEREZ

\_\_\_\_\_

TERRY OLSON

\_\_\_\_\_

JUDY SOLLINGER

\_\_\_\_\_

PAM PARR

\_\_\_\_\_

BRIAN THOMAS

\_\_\_\_\_

**APPROVED** by me, Troy Parlier, as President of the Village of Oswego, Kendall and Will Counties, Illinois this 18<sup>th</sup> day of June 2019.

\_\_\_\_\_  
TROY PARLIER, VILLAGE PRESIDENT

\_\_\_\_\_  
Tina Touchette, Village Clerk

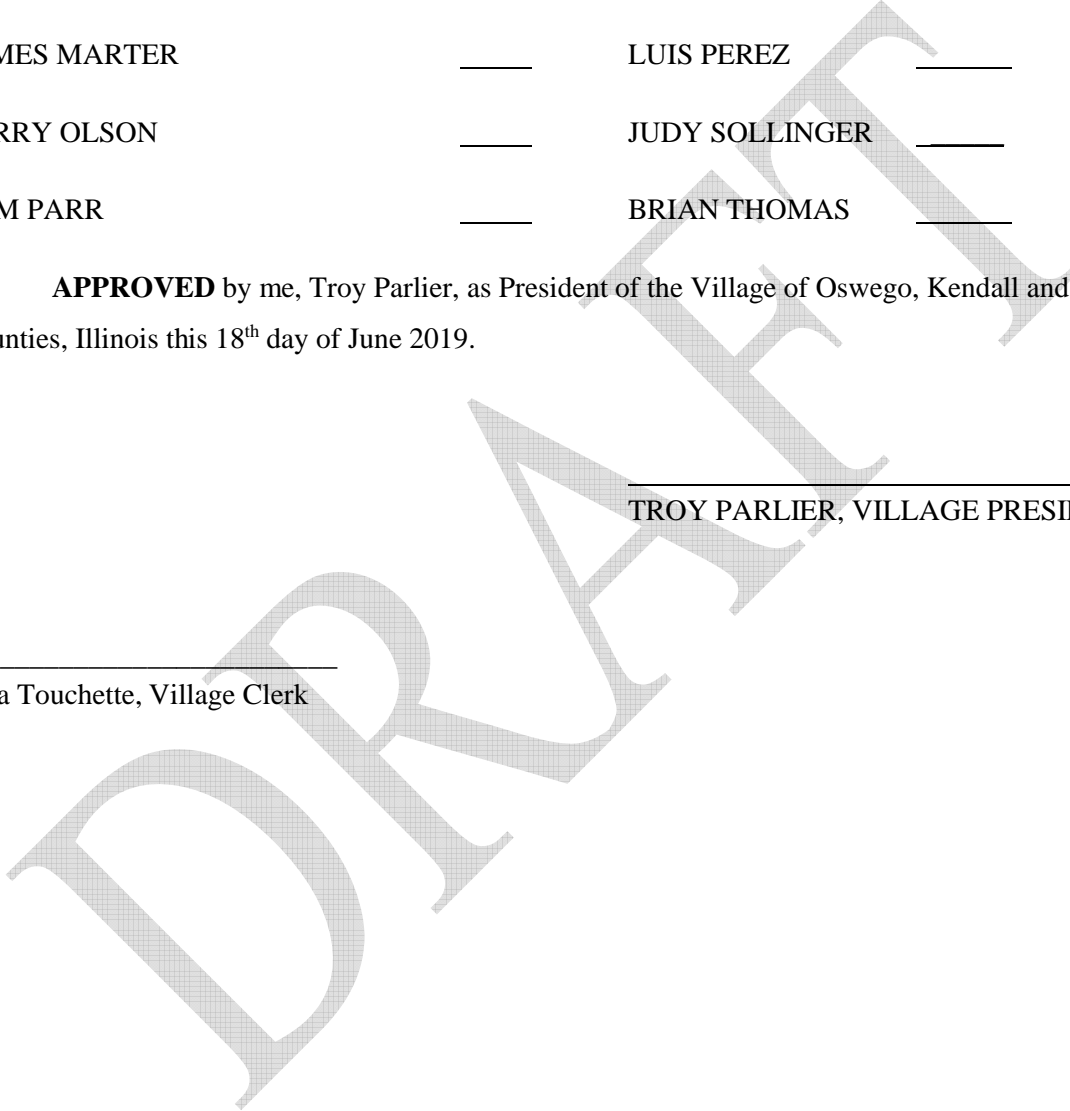



STATE OF ILLINOIS     )  
                                  )     SS  
COUNTY OF KENDALL)

**CLERK'S CERTIFICATE**  
**(RESOLUTION)**

I, Tina Touchette, the duly qualified and acting Village Clerk of the Village of Oswego, Kendall and Will Counties, Illinois, do hereby certify that I am the keeper of its books and records and that the attached hereto is a true and correct copy of a Resolution entitled:

**RESOLUTION APPROVING THE OSWEGO HIGH SCHOOL HOMECOMING PARADE  
AND TEMPORARY CLOSURE OF US HIGHWAY 34 AND IL ROUTE 71**

which Resolution was duly adopted by said Board of Trustees at a meeting held on the 18<sup>th</sup> day of June 2019, and thereafter approved by the Village President on the 18<sup>th</sup> day of June 2019.

I do further certify, in my official capacity, that a quorum of said Board of Trustees was present at said meeting and that the Board complied with all requirements of the Illinois Open Meetings Act.

IN WITNESS WHEREOF, I have hereunto set my hand this \_\_\_\_ day of June 2019.

\_\_\_\_\_  
Tina Touchette, Village Clerk  
Village of Oswego

(Seal)



**AGENDA ITEM**

**MEETING TYPE:** Village Board

**MEETING DATE:** June 18, 2019

**SUBJECT:** Forensic Equipment Memorandum of Understanding – Aurora PD

**ACTION REQUESTED:**

Resolution Authorizing the Execution of a Memorandum of Understanding Between the Oswego Police Department and the City of Aurora Police Department Regarding Use of the Aurora Police Department National Integrated Ballistic Information Network System.

**BOARD/COMMISSION REVIEW:**

N/A

**ACTION PREVIOUSLY TAKEN:**

Date of Action	Meeting Type	Action Taken
NA	NA	NA

**DEPARTMENT:** Police

**SUBMITTED BY:** Jeff Burgner – Chief of Police

**FISCAL IMPACT:**

None

**BACKGROUND:**

The Oswego Police Department has a close working relationship with many of the area police agencies including the City of Aurora Police Department (APD). These mutual aid partnerships many times includes sharing resources such as police equipment. APD recently started a program in partnership with the Bureau of Alcohol, Tobacco and Firearms (ATF) in which the ATF houses a forensics ballistic system at APD Headquarters that can be used to conduct forensic analysis of firearms related evidence. This system, National Integrated Ballistic Information Network (NIBIN) is technology that can allow a trained user of the system to analyze firearms related evidence such as shell casings or firearms in order to determine if there is a link to different criminal incidents where firearms were used.

**DISCUSSION:**

The Aurora Police Department has invited the Oswego Police Department and other neighboring jurisdictions to participate in the use of their NIBIN system to assist in linking criminal activity. The Oswego Police Department would have our Evidence Custodian receive training on this equipment. The training and ability to use the NIBIN system would come with no direct cost to the Village other than staff time to attend training and use the equipment. A benefit to using this equipment is the quick turnaround time for the analysis. Typically, the police department would send any weapons or shell casings to the Illinois State Police Crime Lab. The turnaround time for that analysis would generally be over nine months depending on the type of crime.

Under this agreement, the Oswego Police Department would have direct access at the Aurora Police Headquarters to utilize the NIBIN equipment. We would in turn share our ballistic information with other users to attempt link crimes together from other agencies. The cost of the equipment and maintenance is covered in an agreement with Aurora Police Department and the ATF.

**RECOMMENDATION:**

Staff recommends the approval of the resolution authorizing the execution of a Memorandum of Understanding between the Oswego Police Department and the City of Aurora Police Department regarding the use of the Aurora Police Department National Integrated Ballistic Information Network system.

**ATTACHMENTS:**

Resolution

Exhibit A – Memorandum of Understanding

**RESOLUTION NO. 19 - R - \_\_\_\_**

---

**RESOLUTION AUTHORIZING THE EXECUTION OF A MEMORANDUM OF UNDERSTANDING BETWEEN THE OSWEGO POLICE DEPARTMENT AND THE CITY OF AURORA POLICE DEPARTMENT REGARDING USE OF THE AURORA POLICE DEPARTMENT NATIONAL INTEGRATED BALLISTIC INFORMATION NETWORK SYSTEM.**

---

**WHEREAS**, the Village of Oswego (“Village”) has a population of more than 25,000 and is therefore a “Home Rule Unit” under the 1970 Illinois Constitution; and

**WHEREAS**, the Illinois Constitution of 1970 provides that a Home Rule Unit may exercise any power and perform any function pertaining to its government and affairs, including but not limited to the power to regulate for the protection of the public health, safety, morals and welfare; to license, to tax; and to incur debt; and

**WHEREAS**, the Oswego Police Department supports law enforcement partnerships to enhance the level of police services for the Village of Oswego.

**WHEREAS**, it is in the best interest of the Village of Oswego to approve the agreement substantially in the form attached hereto marked as “Exhibit A”.

**NOW, THEREFORE, BE IT RESOLVED BY THE PRESIDENT AND BOARD OF TRUSTEES OF THE VILLAGE OF OSWEGO, KENDALL AND WILL COUNTIES, ILLINOIS,** as follows:

**SECTION 1. INCORPORATION OF RECITAL**

That the recitals set forth above are incorporated here by reference.

**SECTION 2. SUPPORT FOR AGREEMENT**

The Village President and Village Board of Trustees are hereby authorized and directed to execute on behalf of the Village of Oswego an intergovernmental agreement between the City of Aurora Police Department and the Oswego Police Department regarding the use of the Aurora Police Department National Integrated Ballistic Information Network Systems substantially in the form attached as “Exhibit A.”

**SECTION 3. REPEALER**

All Resolutions or parts of Resolutions in conflict with any of the provisions of this Resolution shall be, and the same hereby repealed.

**SECTION 4. SEVERABILITY**

This Resolution and every provision thereof shall be considered severable. If any section, paragraph, clause or provision of this Resolution is declared by a court of law to be invalid or unconstitutional, the invalidity or unconstitutionality thereof shall not affect the validity of any other provisions of this Resolution.

**SECTION 5. EFFECTIVE DATE**

This Resolution shall be in full force and effect from and after its passage.

**PASSED** by the Board of Trustees of the Village of Oswego, Kendall and Will Counties, Illinois this \_\_\_ day of \_\_\_ 2019.

JAMES MARTER	_____	LUIS PEREZ	_____
TERRY OLSON	_____	JUDY SOLLINGER	_____
PAM PARR	_____	BRIAN THOMAS	_____

**APPROVED** by me, Troy Parlier, as President of the Village of Oswego, Kendall and Will Counties, Illinois this \_\_\_\_ day of \_\_\_\_ 2019.

\_\_\_\_\_  
TROY PARLIER, VILLAGE PRESIDENT

\_\_\_\_\_  
Tina Touchette, Village Clerk

STATE OF ILLINOIS     )  
  )  
COUNTY OF KENDALL    )       SS

**CLERK'S CERTIFICATE**  
**(RESOLUTION)**

I, Tina Touchette, the duly qualified and acting Village Clerk of the Village of Oswego, Kendall and Will Counties, Illinois, do hereby certify that I am the keeper of its books and records and that the attached hereto is a true and correct copy of a Resolution entitled:

**RESOLUTION AUTHORIZING THE EXECUTION OF A MEMORANDUM OF UNDERSTANDING BETWEEN THE OSWEGO POLICE DEPARTMENT AND THE CITY OF AURORA POLICE DEPARTMENT REGARDING USE OF THE AURORA POLICE DEPARTMENT NATIONAL INTEGRATED BALLISTIC INFORMATION NETWORK SYSTEM.**

which Resolution was duly adopted by said Board of Trustees at a meeting held on the \_\_\_ day of \_\_\_\_\_ 2019, and thereafter approved by the Village President on the \_\_\_ day of \_\_\_\_\_ 2019.

I do further certify, in my official capacity, that a quorum of said Board of Trustees was present at said meeting and that the Board complied with all requirements of the Illinois Open Meetings Act.

IN WITNESS WHEREOF, I have hereunto set my hand this \_\_\_ day of \_\_\_\_\_ 2019.

\_\_\_\_\_  
Tina Touchette, Village Clerk  
Village of Oswego

(Seal)

**MEMORANDUM OF UNDERSTANDING**  
**BETWEEN**  
**THE CITY OF AURORA POLICE DEPARTMENT**  
**AND**  
**OSWEGO POLICE DEPARTMENT**

**1. PURPOSE**

The purpose of this Memorandum of Understanding (MOU) between the City of Aurora Police Department (APD) and the Oswego Police Department (OPD), hereinafter referred to as the “parties” is to define the responsibilities of the parties with respect to the scheduling and use of APD’s National Integrated Ballistic Information Network (NIBIN). It sets forth the agreed upon procedures for management, accountability, direction, authority, and liabilities of the parties in conjunction with this effort.

**2. BACKGROUND**

This MOU is being executed for the purpose of enhancing the parties’ efforts to combat, link, and solve violent crimes involving firearms. The parties have entered into this agreement to accomplish each party’s objective to resolve violent crimes through participation in the NIBIN program.

The parties understand that participation in the NIBIN program is contingent on continued approval from the Bureau of Alcohol, Tobacco and Firearms (ATF) through a MOU between ATF and APD, which is incorporated by reference into this MOU. The NIBIN network and certain associated computer systems are the property of ATF and the U.S. Government. ATF has granted APD permission to use the NIBIN network and two computer systems (e.g., one entry station and one analysis station), which are under APD’s operational control, facility space, and exclusive control. As an ATF NIBIN partner, APD may provide NIBIN network and systems access to another law enforcement agency provided the other law enforcement agency agrees to the same restrictions on the use of the NIBIN network and systems as placed on APD.

The parties agree that APD possesses the necessary network access, equipment, space and ballistic facility. The parties recognize that their objectives are best met through integrated and coordinated actions that leverage their respective expertise and infrastructure through robust information sharing.



### **3. SCOPE**

This MOU defines the responsibilities of the parties to the agreement.

The parties will be responsible for the following:

- a. Oswego Police Department will provide personnel who have successfully completed certification training for the purpose of acquiring, reviewing, and analyzing data.
- b. Oswego Police Department will be responsible for its own evidentiary chain of custody and will provide personnel to conduct their own examinations. No items of evidence will be stored at APD facilities. Oswego Police Department will be responsible for entering its own evidence to include test fired specimens from recovered weapons.
- c. Oswego Police Department will adhere to any “use of equipment” schedule for routine use, review and analysis to promote efficient and effective operations of any APD ballistics identification system. In the event of a high profile or urgent case, expedited processing outside of any “use of equipment” schedule may be necessary. The parties agree to communicate with any other affected parties to other APD NIBIN agreements to ensure minimization of impact to the other parties.
- d. Oswego Police Department will comply with all federal security requirements related to the NIBIN program, network, or systems to ensure the integrity of the program. These requirements are set forth under NIBIN security policies and the ATF-APD MOU incorporated by reference into this MOU.
- e. Oswego Police Department will adhere to the same restrictions on the use of the NIBIN program, network, or systems that have been placed upon APD under the ATF-APD MOU. This includes, but is not limited to, clauses in the ATF-APD MOU regarding the scope of the NIBIN program, publicity, disclosure of information related to NIBIN, and personnel and training requirements. These requirements are set forth under the ATF-APD MOU incorporated by reference into this MOU.

### **4. FUNDING**

Each party to this MOU shall be responsible for its own costs associated with implementing its requirements under this MOU. Any expenditure of funds is subject to the availability of said funds.

## **5. DISCLOSURE AND USE OF INFORMATION**

The parties agree to the following disclosure and use policy. The parties may share information with each other in accordance with the rules of its own agency. Information which is shared between the parties may be used by the recipient for any authorized law enforcement purpose.

## **6. SETTLEMENT OF DISPUTES**

Disagreements between the parties arising under or related to this MOU will be resolved by consultation between the parties and will not be referred to a Federal or State court or entity for settlement. The parties agree to make every effort to settle disagreements at the lowest level appropriate under the circumstances. In the event of an impasse or issues beyond the authority of APD and Oswego Police Department personnel involved, the matter in dispute will be referred to the parties' respective headquarters for resolution. This section does not affect APD's right to seek indemnification under Paragraph 9 below.

## **7. COORDINATION AND DECONFLICTION**

If analysis of a shell casing identifies a potential high confidence candidate that crosses regional jurisdictional boundaries, the parties agree to collaborate with other law enforcement agencies as quickly as possible to advance the investigation.

The parties will coordinate and deconflict through their representatives prior to taking operational action based in whole or in part from information received or derived from another party pursuant to this MOU.

## **8. AMENDMENT, TERMINATION, ENTRY INTO FORCE, AND DURATION**

With regard to amendment, termination, entry into force, and duration of this agreement the following procedures apply:

- a. Except as otherwise provided, this MOU may only be amended by the mutual written consent of the parties' authorized representatives.
- b. This MOU may be terminated at any time upon the mutual written consent of the parties. In the event both parties consent to terminate this MOU, the parties agree to ensure termination on the most economical and equitable terms for both parties.
- c. Either party may terminate this MOU upon 30 days written notification to the other party.

In the event of such termination, the following rules apply:

- a. The termination party will continue to participate up to the effective date of termination.
- b. Each party will pay its own costs incurred as a result of termination.
- c. All information and rights therein received under the provisions of the MOU prior to the termination will be retained by the parties, subject to the provisions of this MOU.

## **9. INDEMNIFICATION**

Each party agrees to defend, indemnify and hold harmless the other, including its employees and officers, for any and all claims, suits, causes or action, damages, or the like or for the cost incurred in any adjudication or settlement of the foregoing. This includes, but is not limited to, attorney's fees and costs, which may arise from any alleged use or misuse of documents, equipment, facilities or information provided by APD pursuant to this MOU, or by any negligent or willful and wanton act or omission on the part of either party. This also specifically includes any costs incurred to investigate potential breaches of this data and, where applicable, the cost of notifying individuals who may be impacted by the breach.

## **10. DURATION**

This MOU will be effective upon signature of both parties and will remain in effect for five years. It may be extended by mutual written consent of the parties' authorized representatives.

## **11. ENTIRE AGREEMENT**

The foregoing represents the entire agreement and understandings reached by the parties referred to herein. There are no representations or other provisions other than those contained herein, and any amendment to or modification of this MOU will be made only in writing and signed by the Parties.

In witness thereof, the parties have hereby executed this Memorandum of Understanding this \_\_\_\_\_ day of \_\_\_\_\_, 2019, by their duly authorized representative

**FOR THE OSWEGO POLICE DEPARTMENT**

\_\_\_\_\_  
Signature

\_\_\_\_\_  
Date

Name:

Title:

Location:

APPROVED AS TO FORM:

\_\_\_\_\_  
Interim Corporation Counsel

\_\_\_\_\_  
Date

**FOR THE AURORA POLICE DEPARTMENT**

\_\_\_\_\_  
Signature

\_\_\_\_\_  
Date

Name:

Title:

Location:

APPROVED AS TO FORM:

\_\_\_\_\_  
Assistant Corporation Counsel

\_\_\_\_\_  
Date

**AGENDA ITEM**

**MEETING TYPE:** Village Board

**MEETING DATE:** June 18, 2019

**SUBJECT:** Authorized Depositories and Authorized Signers for Village Banking

**ACTION REQUESTED:**

Adopt Resolution Designating Depositories and Signers for Village Banking Services and Accounts

**BOARD/COMMISSION REVIEW:**

Click here to enter text.

**ACTION PREVIOUSLY TAKEN:**

Date of Action	Meeting Type	Action Taken
Click here to enter a date.	Click here to enter text.	Click here to enter text.

**DEPARTMENT:** Finance

**SUBMITTED BY:** Mark G. Horton, CPFO, Finance Director

**FISCAL IMPACT:**

N/A

**BACKGROUND:**

The Village finance department follows best practices for cash management of Village funds. Adopting resolutions designating where village funds are deposited and designating which individuals may provide instructions for depositories to act upon and which individuals may sign village issued checks follows one of these best practices.

**DISCUSSION:**

The Village President is one of the signatories on all Village issued checks. With the election of the new Village President May 1, 2019, the Village must adopt the new Resolution to file with all the financial institutions utilized noting the signatory change.

**RECOMMENDATION:**

Adopt the resolution.

**ATTACHMENTS:**

Resolution

**RESOLUTION NO. 19 - R - \_\_\_\_**

---

**A RESOLUTION  
DESIGNATING  
DEPOSITORIES AND  
SIGNERS FOR VILLAGE  
BANKING SERVICES AND  
ACCOUNTS**

---

**WHEREAS**, the Village of Oswego (“Village”) has a population of more than 25,000 and is therefore a “Home Rule Unit” under the 1970 Illinois Constitution; and

**WHEREAS**, the Illinois Constitution of 1970 provides that a Home Rule Unit may exercise any power and perform any function pertaining to its government and affairs, including but not limited to the power to regulate for the protection of the public health, safety, morals and welfare; to license, to tax; and to incur debt; and

**WHEREAS**, it is in the best interest of the Village of Oswego to approve the Authorized Depository and Designated Signers for all Village banking services substantially in the form attached hereto marked as “Exhibit A”.

**NOW, THEREFORE, BE IT RESOLVED BY THE PRESIDENT AND BOARD OF TRUSTEES OF THE VILLAGE OF OSWEGO, KENDALL AND WILL COUNTIES, ILLINOIS**, as follows:

**SECTION 1. INCORPORATION OF RECITAL**

That the recitals set forth above are incorporated here by reference.

**SECTION 2. AUTHORIZATION AND DEPOSITORY APPROVAL**

The Authorized Depositories together with the individuals empowered to act and signatory requirements set forth in Exhibit A be and are hereby approved and authorized by the Village President and Board of Trustees.

**SECTION 3. REPEALER**

All Resolutions or parts of Resolutions in conflict with any of the provisions of this Resolution shall be, and the same hereby repealed.

**SECTION 4. SEVERABILITY**

This Resolution and every provision thereof shall be considered severable. If any section, paragraph, clause or provision of this Resolution is declared by a court of law to be invalid or unconstitutional, the invalidity or unconstitutionality thereof shall not affect the validity of any other provisions of this Resolution.

**SECTION 5. EFFECTIVE DATE**

This Resolution shall be in full force and effect from and after its passage and approval in the manner provided by law.

**PASSED** by the Board of Trustees of the Village of Oswego, Kendall and Will Counties, Illinois this \_\_\_ day of \_\_\_ 2019.

JAMES MARTER \_\_\_\_\_ LUIS PEREZ \_\_\_\_\_

TERRY OLSON \_\_\_\_\_ JUDY SOLLINGER \_\_\_\_\_

PAM PARR \_\_\_\_\_ BRIAN THOMAS \_\_\_\_\_

**APPROVED** by me, Troy Parlier, as President of the Village of Oswego, Kendall and Will Counties, Illinois this \_\_\_\_\_ day of \_\_\_\_\_ 2019.

\_\_\_\_\_  
TROY PARLIER, VILLAGE PRESIDENT

\_\_\_\_\_  
Tina Touchette, Village Clerk



STATE OF ILLINOIS     )  
  )  
COUNTY OF KENDALL    )            SS

**CLERK'S CERTIFICATE**  
**(RESOLUTION)**

I, Tina Touchette, the duly qualified and acting Village Clerk of the Village of Oswego, Kendall and Will Counties, Illinois, do hereby certify that I am the keeper of its books and records and that the attached hereto is a true and correct copy of a Resolution entitled:

**A RESOLUTION  
DESIGNATING  
DEPOSITORIES AND  
SIGNERS FOR VILLAGE  
BANKING SERVICES AND  
ACCOUNTS**

which Resolution was duly adopted by said Board of Trustees at a meeting held on the \_\_\_ day of \_\_\_\_\_ 2019, and thereafter approved by the Village President on the \_\_\_ day of \_\_\_\_\_ 2019.

I do further certify, in my official capacity, that a quorum of said Board of Trustees was present at said meeting and that the Board complied with all requirements of the Illinois Open Meetings Act.

IN WITNESS WHEREOF, I have hereunto set my hand this \_\_\_ day of \_\_\_\_\_ 2019.

\_\_\_\_\_  
Tina Touchette, Village Clerk  
Village of Oswego

(Seal)

**Exhibit A**

**Authorized Depositories**

Allied First Bank, Oswego, IL  
Bridgeview Bank, Oswego, IL  
First National Bank of Omaha, Oswego, IL  
The Illinois Funds, State Treasurer, US Bank NA  
Old Second National Bank, Oswego, IL  
Byline Bank, Oswego, IL  
US Bank Institutional Trust & Custody, Springfield, IL  
Associated Bank NA, Janesville, WI

**Individuals empowered to act on behalf of the Village regarding any banking services**

Troy Parlier, Village President  
Daniel Di Santo, Village Administrator  
Mark G Horton, Finance Director/Village Treasurer  
Billie Robinson, Asst. Finance Director

**Authorized Signers (two signatures: actual, facsimiles or electronic) required on all Village issued checks from the following list:**

Troy Parlier, Village President  
Judith A Sollinger, Village Trustee  
Mark G Horton, Finance Director/Village Treasurer  
Billie Robinson, Asst. Finance Director

**AGENDA ITEM**

**MEETING TYPE:** Village Board

**MEETING DATE:** June 18, 2019

**SUBJECT:** Elected Official Participation in IMRF

**ACTION REQUESTED:**

Approval of A Resolution Relating to Participation by Elected Officials in the Illinois Municipal Retirement Fund

**BOARD/COMMISSION REVIEW:**

N/A

**ACTION PREVIOUSLY TAKEN:**

Date of Action	Meeting Type	Action Taken
05/02/2017	Village Board Meeting	Approval of A Resolution Relating to Participation by Elected Officials in the Illinois Municipal Retirement Fund
10/6/2015	Village Board Meeting	Approval of a Resolution to Rescind IMRF participation for Village Trustees
9/15/2015	Committee of the Whole	Discussion on continuing IMRF participation for Elected Officials
Late 1984	Village Board Meeting	Village Board approval of elected clerk, governing body and Village President eligible to participate in IMRF effective 1-1-1985
April 2, 1979	Village Board Meeting	Village Board approved resolution authorizing Village employee participation in IMRF effective 1-1-1980.

**DEPARTMENT:** Human Resource

**SUBMITTED BY:** Christina Burns, Assistant Village Administrator

**FISCAL IMPACT:**

Participation of the Village President in IMRF is included in the Village’s IMRF funding for FY2020.

**BACKGROUND:**

In the 1980s, the Village Board adopted IMRF participation for all elected officials. Following a routine IMRF member audit and discussion at a 2016 Committee of the Whole, it was determined that only the Village President met the 1,000-hour threshold for participation in IMRF. At that time, the Village Board elected to eliminate IMRF participation by Village Trustees but continue participation for the Village President.

**DISCUSSION:**

Since in 2017, IMRF is requiring all municipalities who have elected officials who participate in IMRF to re-certify participation every two years.

The attached Resolution continued elected official participation in IMRF by the Village President.

**RECOMMENDATION:**

Approval of a Resolution Relating to Participation by Elected Officials in the Illinois Municipal Retirement Fund

**ATTACHMENTS:**

A Resolution Relating to Participation by Elected Officials in the Illinois Municipal Retirement Fund



# A RESOLUTION RELATING TO PARTICIPATION BY ELECTED OFFICIALS IN THE ILLINOIS MUNICIPAL RETIREMENT FUND

IMRF Form 6.64 (Rev. 03/17) (Income tax information can be found on the reverse side of this resolution)

PLEASE ENTER Employer IMRF I.D. Number  
00710

## RESOLUTION

Number \_\_\_\_\_

WHEREAS, the Village of Oswego  
EMPLOYER NAME

is a participant in the Illinois Municipal Retirement Fund; and

WHEREAS, elected officials may participate in the Illinois Municipal Retirement Fund if they are in positions normally requiring performance of duty for 1,000 hours or more per year; and  
600 OR 1,000

WHEREAS, this governing body can determine what the normal annual hourly requirements of its elected officials are, and should make such determination for the guidance and direction of the Board of Trustees of the Illinois Municipal Retirement Fund;\*

NOW THEREFORE BE IT RESOLVED that the Board of Trustees  
BOARD, COUNCIL, ETC.  
finds the following elected positions qualify for membership in IMRF.

TITLE OF ELECTED POSITION	DATE POSITION BECAME QUALIFIED
<u>Village President</u>	<u>1-1-1985</u>
_____	_____
_____	_____

## CERTIFICATION

I, \_\_\_\_\_, the \_\_\_\_\_  
NAME CLERK OR SECRETARY OF THE BOARD  
of the \_\_\_\_\_ of the County of \_\_\_\_\_,  
EMPLOYER NAME COUNTY  
State of Illinois, do hereby certify that I am keeper of its books and records and that the foregoing is a true and correct copy of a resolution duly adopted by its \_\_\_\_\_ at a meeting duly  
BOARD, COUNCIL, ETC.  
convened and held on the \_\_\_\_\_ of \_\_\_\_\_, 20\_\_\_\_.  
DAY MONTH YEAR

\_\_\_\_\_  
SIGNATURE CLERK OR SECRETARY OF THE BOARD

\* Any person who knowingly makes any false statement or falsifies or permits to be falsified any record of the Illinois Municipal Retirement Fund in an attempt to defraud IMRF is guilty of a Class 3 felony (40 ILCS 5/1-135).

### IMRF

2211 York Road, Suite 500, Oak Brook, Illinois 60523-2337  
Employer Only Phone: 1-800-728-7971  
www.imrf.org

**Village of Oswego  
Bill List  
June 4, 2019**

<u>Fund/Department:</u>	<u>Vendor Name:</u>	<u>Description:</u>	<u>Amount:</u>	<u>Department Totals:</u>
<b>General Fund:</b>				
Corporate:				
1001100	CareerBuilder	Pre-Employment Screening Services	48.75	
1001100	Fox Valley Trophy & Awards	Plastic Signs, Name Badges	29.00	
1001100	Fox Valley Trophy & Awards	PW Plastic Sign	8.00	
1001100	ILCMA	ILCMA Job Posting for Project Engineer	50.00	
1001100	IPRF	Workers Compensation Insurance	835.14	
1001100	Metro West Council of Government	May MetroWest Board Meeting	70.00	
1001100	NIU Centerr for Government Studies	Session 1 and 2 of Growing Together	1,683.34	
1001100	Officeteam	Temporary Executive Assistant	1,068.20	
1001100	Officeteam	Temporary Executive Assistant	423.49	
1001100	Officeteam	Temporary Executive Assistant	1,085.17	
1001100	Sterling Codifiers, INC	Supplement #42, Ordinances	1,519.00	
1001100	Time Stops Photography	22 Portraits-Directors, Officials	2,200.00	
			<b>Corporate Total:</b>	<b>9,020.09</b>
Community Relations:				
1002000	IPRF	Workers Compensation Insurance	250.54	
1002000	Widely Interactive LLC	Go Oswego Website Updates	524.50	
			<b>Community Relations Total:</b>	<b>775.04</b>
Building & Zoning:				
1002500	IPRF	Workers Compensation Insurance	835.14	
1002500	Oswego Printing Service	Approved Sticker Label, Qty 2000	165.00	FY19
1002500	P F Pettibone & Co.	Ordinance Violation Tickets	1,049.40	FY19
1002500	Riverview Ford	Vehicle Maintenance	34.23	FY19
1002500	Thompson Elevator Inpections	Semi-Annual Inspection	50.00	
			<b>Building &amp; Zoning Total:</b>	<b>2,133.77</b>
Community Development:				
1003000	Cirone, Dominick	PZC Meeting 05/23/19	25.00	
1003000	Holmstrom, Kenneth	PZC Meeting 05/23/19	25.00	
1003000	IPRF	Workers Compensation Insurance	445.41	
1003000	Kuhn, Rick	PZC Meeting 05/23/19	25.00	
1003000	Novy, Karen E	PZC Meeting 05/23/19	25.00	
1003000	Pajor, Charles	PZC Meeting 05/23/19	25.00	
1003000	Stine, Rebecca	PZC Meeting 05/23/19	25.00	
			<b>Community Development</b>	<b>595.41</b>
Economic Development:				
1003500	IPRF	Workers Compensation Insurance	111.35	
			<b>Economic Development:</b>	<b>111.35</b>
Finance:				
1004000	IPRF	Workers Compensation Insurance	668.11	
1004000	Oswego Printing Service	AP & Payroll Envelopes	679.20	
			<b>Finance Total:</b>	<b>1,347.31</b>
Information Technologies:				
1004500	Bluebeam Software	Bluebeam Annual Maintenance Renewal	318.00	
1004500	Fathom Media, INC	Interactive Touchscreen for PW	13,704.13	FY19
1004500	Interdev, LLC.	InterDev - Onsite Support	11,404.32	FY19
1004500	IPRF	Workers Compensation Insurance	111.35	
1004500	WatchGuard Video	WatchGuard Maintenance Renewal	6,475.00	
			<b>Information Technologies Total:</b>	<b>32,012.80</b>
Police:				
1005030	IPRF	Workers Compensation Insurance	7,239.85	
			<b>Police Total:</b>	<b>7,239.85</b>
Public Works:				
1006050	Al Warren Oil Co, INC	Diesel Fuel Purchase for Village	511.92	
1006050	Al Warren Oil Co, INC	Village Fuel Purchase	812.14	
1006060	Aramark Corporation	Mat Service - PD	43.87	
1006010	Clarke Mosquito Control	Mosquito Control	20,849.53	
1006030	Comed	Master Account Traffic Signals	453.27	FY19
1006030	Comed	Master Acct St Lights	3,806.16	FY19
1006030	Frost Electric Company	Street Light Repair	5,825.00	FY19
1006030	Frost Electric Company	Street Light Repair	250.00	FY19
1006030	Frost Electric Company	Street Light Repair	270.00	FY19
1006030	Frost Electric Company	Street Light Repair: Pearces Ford	575.00	FY19

**Village of Oswego  
Bill List  
June 4, 2019**

<u>Fund/Department:</u>	<u>Vendor Name:</u>	<u>Description:</u>	<u>Amount:</u>	<u>Department Totals:</u>
1006030	Frost Electric Company	Streetlight Repair	1,300.00	FY19
1006030	Graybar Electric Co	Street Light Supplies	308.16	FY19
1006010	Groot Industries, INC	Four 30 Yard Dumpsters	4,750.00	FY19
1006060	Imperial Service Systems	Monthly Janitorial Services-PD	3,276.00	
1006060	Imperial Service Systems	Monthly Janitorial Services-PW	311.00	
1006060	Imperial Service Systems	Monthly Janitorial Services-VH	1,886.00	
1006030	IPRF	Workers Compensation Insurance	2,061.00	
1006060	Johnson Controls, INC	VH - Repairs to AHU 2 Chiller	458.10	
1006030	Meade Electric Company	Traffic Signal Locate	156.69	FY19
1006030	Meade Electric Company	Traffic Signal Locate	221.99	FY19
1006030	Meade Electric Company	Traffic Signal Locate	223.94	FY19
1006030	Meade Electric Company	Traffic Signal Locate	228.49	FY19
1006030	Meade Electric Company	Traffic Signal Locate	150.19	FY19
1006030	Meade Electric Company	Traffic Signal Locate	293.14	FY19
1006030	Meade Electric Company	Traffic Signal Locate	143.60	FY19
1006030	Meade Electric Company	Traffic Signal Repair	315.43	FY19
1006030	Meade Electric Company	Traffic Signal Repair	3,312.00	FY19
1006030	Meade Electric Company	Traffic Signal Repair	761.72	FY19
1006030	Meade Electric Company	Traffic Signal Repair	215.40	FY19
1006030	Meade Electric Company	Traffic Signal Repair	610.68	FY19
1006030	Meade Electric Company	Traffic Signal Repair	175.80	FY19
1006030	Meade Electric Company	Traffic Signal Repair	2,244.92	FY19
1006030	Meade Electric Company	Traffic Signal Repair	532.53	FY19
1006030	Meade Electric Company	Traffic Signal Repair	143.60	FY19
1006030	Meade Electric Company	Traffic Signal Repair	151.38	FY19
1006030	Meade Electric Company	Traffic Signal Repair	300.21	FY19
1006060	Warehouse Direct	5 Cases Toilet Tissue	207.50	
1006060	Warehouse Direct	PD-Carton of Cleaner	50.73	
1006060	Warehouse Direct	PD-Trash Bags, Paper Towels, SS Polish	552.19	

Public Works Total: 58,739.28

General Fund Total: 111,974.90

**Water & Sewer Fund:**

5006070	Al Warren Oil Co, INC	Diesel Fuel Purchase for Village	625.69	
5006070	Al Warren Oil Co, INC	Village Fuel Purchase	992.62	
5006070	Comed	1613 Rt. 34 Booster 2	193.65	FY19
5006070	Comed	Master Account Lift Stations	478.32	FY19
5006070	Comed	Well 7 - 378 Ogden Falls	751.88	FY19
5006070	Concentric Integration	171185.00-Support Services	11,250.00	
5006070	IL Environmental Protection Agency	Drinking Water Project	37,346.69	
5006070	IL Environmental Protection Agency	Drinking Water Project	6,003.65	
5006070	Imperial Service Systems	Monthly Janitorial Services-PW	311.00	
5006070	IPRF	Workers Compensation Insurance	668.11	
5006070	Third Millennium	Regular Utility Bills, Modification	2,141.00	
5006070	Water Remediation Technology	Base Treatment Charge	3,725.55	
5006070	Water Remediation Technology	Base Treatment Charge	6,101.14	
5006070	Water Remediation Technology	Base Treatment Charge	4,768.70	
5006070	Water Remediation Technology	Base Treatment Charge	4,768.70	
5006070	Water Remediation Technology	Base Treatment Charge	4,768.70	
5006070	Water Remediation Technology	Base Treatment Charge	4,768.70	
5006070	Water Remediation Technology	Base Treatment Charge	4,768.70	
5006070	Water Remediation Technology	Base Treatment Charge	4,768.70	
5006070	Water Remediation Technology	Excess Volume Charge	1,863.72	
5006070	Water Remediation Technology	Excess Volume Charge	887.58	
5006070	Water Remediation Technology	Excess Volume Charge	2,541.68	
5006070	Water Remediation Technology	Excess Volume Credit	-2,144.90	
5006070	Water Remediation Technology	Excess Volume Credit	-3,256.70	
5006070	Water Remediation Technology	Excess Volume Credit	-2,026.24	
5006070	Water Remediation Technology	Excess Volume Credit	-3,725.56	
5006070	Water Remediation Technology	Excess Volume Credit	-1,567.67	

Water & Sewer Fund: 91,773.41

**Water & Sewer Capital Fund:**

5106070	Strand Associates, INC	PW Lift Station Generator Engineering	10,189.05	FY19
5106070	Ferguson Waterworks	Water Meter Purchase	3,410.39	
5106070	Ferguson Waterworks	Water Meter Purchase	4,396.63	
5106070	Ferguson Waterworks	Water Meter Purchase	452.39	
5106070	Ferguson Waterworks	Water Meter Purchase	159,635.00	
5106070	Ferguson Waterworks	Water Meter Purchase	11,376.48	
5106070	Ferguson Waterworks	Water Meter Purchase	51,725.00	

**Village of Oswego  
Bill List  
June 4, 2019**

<u>Fund/Department:</u>	<u>Vendor Name:</u>	<u>Description:</u>	<u>Amount:</u>	<u>Department Totals:</u>
			Water & Sewer Capital Fund:	241,184.94
<b>Capital Fund:</b>				
3003000	Alfred Benesch & Company	Wolf's Crossing Phase 1 Study	11,977.43	FY19
3003000	ClientFirst Consulting	Project Oversight: Implementation #2	5,175.66	FY19
3003000	IL Department of Transportation	IL 47 & US 34 Construction	1,866.08	FY19
3003000	Kasper & Nottage, PC	Lobbyist Services	7,000.00	
3003000	Tyler Technologies,INC	ERP Implementation Phase 5	20,130.43	FY19
			Capital Fund:	46,149.60
<b>Special Events Fund:</b>				
2302000	Angelos Intl Concessions	Deposit Refund-Wine on the Fox	200.00	
2302000	ASCAP	ASCAP Fees for Events	363.56	
2302000	August Hill Winery	Deposit Refund-Wine on the Fox	200.00	
2302000	August Hill Winery	Wine on the Fox-Ticket Payout	2,004.00	
2302000	Auntie Anne's Pretzel Co	Deposit Refund-Wine on the Fox	200.00	
2302000	Bike Bald Group	Volunteer Donation-Wine on the Fox	400.00	
2302000	Cooper's Hawk Winery	Deposit Refund-Wine on the Fox	200.00	
2302000	Cooper's Hawk Winery	Wine on the Fox-Ticket Payout	1,516.80	
2302000	First Place Rental	4 Light Towers - WOTF	604.00	
2302000	Floral Expressions	16 Wine Table Floral Pieces - WOTF	240.00	
2302000	Fox Creek Vineyard	Deposit Refund-Wine on the Fox	200.00	
2302000	Fox Creek Vineyard	Wine on the Fox-Ticket Payout	723.00	
2302000	Fox Metro Kiwanis	Volunteer Donation-Wine on the Fox	319.68	
2302000	Fox Valley Winery	Deposit Refund-Wine on the Fox	200.00	
2302000	Fox Valley Winery	Wine on the Fox-Ticket Payout	1,403.40	
2302000	Galena Cellars	Deposit Refund-Wine on the Fox	200.00	
2302000	Galena Cellars	Wine on the Fox-Ticket Payout	2,485.80	
2302000	Genoa Italian Concessions	Deposit Refund-Wine on the Fox	200.00	
2302000	Help Save Pets	Volunteer Donation-Wine on the Fox	119.88	
2302000	Hoffman, Julie	Reimb for WOTF, Cups, Tape, Bags	73.02	
2302000	Home City Ice	Wine on the Fox - Ice	1,053.00	
2302000	Illinois River Winery	Deposit Refund-Wine on the Fox	200.00	
2302000	Illinois River Winery	Wine on the Fox-Ticket Payout	715.20	
2302000	Imperial Service Systems	Emergency Restroom/Lobby Clean - WOTF	250.00	
2302000	John Werle	Christmas Walk - DJ Deposit	225.00	
2302000	Kendall County Comm Food Bank	Volunteer Donation-Wine on the Fox	123.21	
2302000	Kickapoo Creek Winery	Deposit Refund-Wine on the Fox	200.00	
2302000	Kickapoo Creek Winery	Wine on the Fox-Ticket Payout	1,384.20	
2302000	Kiwanis of Aurora	Volunteer Donation-Wine on the Fox	106.56	
2302000	Lavender Crest Winery	Deposit Refund-Wine on the Fox	200.00	
2302000	Lavender Crest Winery	Wine on the Fox-Ticket Payout	1,517.40	
2302000	Oswego Jr Womans Club	Volunteer Donation-Wine on the Fox	246.42	
2302000	Oswegoland Seniors	Volunteer Donation-Wine on the Fox	226.44	
2302000	Patten Cat	4 Generator Rentals - WOTF	2,544.00	
2302000	Pizza Cucina	Deposit Refund-Wine on the Fox	200.00	
2302000	Popcorn Store	Deposit Refund-Wine on the Fox	200.00	
2302000	Prairie State Winery	Deposit Refund-Wine on the Fox	200.00	
2302000	Prairie State Winery	Wine on the Fox-Ticket Payout	1,645.80	
2302000	Premier Mailing & Printing	WOTF-16 Page Booklet	2,048.96	
2302000	Quick Signs	Wine on the Fox - Park At Own Risk	144.00	
2302000	Quick Signs	Wine on the Fox Banners - 3	288.00	
2302000	Quick Signs	Wine on the Fox Signs - Various	1,449.00	
2302000	Simply Destinee	Volunteer Donation-Wine on the Fox	400.00	
2302000	Sturmon, Jason	Extended Performance Fee - WOTF	200.00	
2302000	The Rental Place	Equipment Rental - Tents, Etc, WOTF	9,326.40	
2302000	Vahling Vineyard	Deposit Refund-Wine on the Fox	200.00	
2302000	Vahling Vineyard	Wine on the Fox-Ticket Payout	784.80	
2302000	Village Vintner Wine	Deposit Refund-Wine on the Fox	250.00	
2302000	Wurst Kitchen Sausage Co	Deposit Refund-Wine on the Fox	200.00	
			Special Events Fund:	38,381.53
<b>Subdivision Escrow Fund:</b>				
9000000	Baxter & Woodman Co	181042.80 244 E Washington, 7-Eleven	961.87	
9000000	Baxter & Woodman Co	190355.80-1945 Wiesbrook	1,828.79	
9000000	Baxter & Woodman Co	190432.80-4100 Route 71	1,025.00	
			Sub Escrow Fund:	3,815.66
<b>TIF Fund:</b>				
2503500	Fowler Enterprises	Demo of Building at 63 W Washington	18,600.00	
			TIF Fund:	18,600.00



**Village of Oswego  
Bill List  
June 4, 2019**

<u>Fund/Department:</u>	<u>Vendor Name:</u>	<u>Description:</u>	<u>Amount:</u>	<u>Department Totals:</u>
<b>Other General Fund:</b>				
1000000	I.U.O.E. Local 150	Union Dues	860.90	
1000000	I.U.O.E. Local 150	Union Dues	36.00	
1000000	I.U.O.E. Local 150	Union Dues	200.09	
1000000	I.U.O.E. Local 150	Union Dues	860.90	
1000000	I.U.O.E. Local 150	Union Dues	36.00	
1000000	I.U.O.E. Local 150	Union Dues	200.09	
1000000	I.U.O.E. Local 150	Union Dues	200.09	
1000000	I.U.O.E. Local 150	Union Dues	36.00	
1000000	I.U.O.E. Local 150	Union Dues	860.90	
				Other General Fund: <u>3,290.97</u>
				Grand Total: <u><u>555,171.01</u></u>

**Village of Oswego  
Bill List  
June 18, 2019**

<u>Fund/Department:</u>	<u>Vendor Name:</u>	<u>Description:</u>	<u>Amount:</u>	<u>Department Totals:</u>
<b>General Fund:</b>				
Corporate:				
1001100	Officeteam	Temporary Executive Assistant	842.77	
1001100	Parlier, Troy	Travel-ICSC RECon Conference	529.53	
1001100	Peter Burchard, LLC	Innovating the Innovator-Deposit	800.00	
				Corporate Total: <b>2,172.30</b>
Community Development:				
1003000	Brenneman, John	CAMP Registration Reimbursement	37.00	
1003000	Illinois Heritage Assoc	Illinois Heritage Assoc Membership	45.00	
				Community Development <b>82.00</b>
Finance:				
1004000	Gatske, Jennifer	Mileage-Tyler Conference	62.90	FY19
1004000	Horton, Mark	Mileage/Tolls-MyLocalTax Seminar	21.71	
1004000	Horton, Mark	Travel-GFOA Conference	2,284.68	
				Finance Total: <b>2,369.29</b>
Information Technologies:				
1004500	CDW Government, INC	Mimecast Antispam and E-Discovery	2,500.00	
1004500	CDW Government, INC	Mimecast Antispam and E-Discovery	15,023.20	
1004500	Interdev, LLC.	InterDev - Onsite Support	11,404.32	
				Information Technologies Total: <b>28,927.52</b>
Police:				
1005030	I-PAC	I-PAC Membership Dues	100.00	
1005040	Pan, Justin	Meal-FTO Training Class	94.33	
1005030	Petty Cash-Police	Training Meal Reimbursements	26.48	FY19
1005040	Petty Cash-Police	Training Meal Reimbursements	19.37	FY19
1005030	Petty Cash-Police	Training, Notary, Meetings	63.23	
1005030	Petty Cash-Police	Training, Notary, Meetings	20.00	
1005040	Petty Cash-Police	Training, Notary, Meetings	5.00	
1005040	Petty Cash-Police	Training, Notary, Meetings	12.41	FY19
1005030	Physicians Immediate Care	Monthly Random Drug Screens	38.00	
1005030	Plainfield Police	Leadership Seminar	100.00	
1005040	Strypes Plus More	Replace Lettering on Squad Car	150.00	
1005030	Trotsky Investigative Services	2 CSO Polygraphs	280.00	
1005040	White Eagle Auto Body	Squad #14 Repair	843.07	
				Police Total: <b>1,751.89</b>
Public Works:				
1006050	Al Warren Oil Co, INC	Diesel Fuel	889.62	
1006050	Al Warren Oil Co, INC	Village Fuel Purchase	238.84	
1006060	Aramark Corporation	New PD - Mat Service 4/1	43.87	FY19
1006030	Comed	1000 Station Dr, Park & Ride	202.90	
1006030	Comed	104 E. Jackson St Lights	111.24	
1006030	Comed	1945 Wiesbrook Controller	49.26	
1006030	Comed	Master Account Traffic Signals	520.10	FY19
1006060	Compliance Signs	Safe Haven Sign	31.50	
1006030	Frost Electric Company	Street Light Repair	1,535.00	
1006030	Frost Electric Company	Street Light Repair	312.50	
1006030	Frost Electric Company	Street Light Repair	1,315.00	
1006030	Frost Electric Company	Street Light Repair	1,315.00	
1006030	Graybar Electric Co	Street Light Supplies	1,050.00	
1006030	IL Department of Transportation	Traffic Signal Maintenance	341.64	FY19
1006030	Meade Electric Company	Traffic Signal Locate	147.22	
1006030	Meade Electric Company	Traffic Signal Maintenance	455.40	
1006030	Meade Electric Company	Traffic Signal Repair	175.80	
1006010	Physicians Immediate Care	Drug Screen Testing	106.00	
1006060	Schindler Elevator Corp	Quarterly VH Elevator Inspection	664.35	
1006060	Security Builders Supply	PW - Re-key Asst Director's Office	20.00	
				Public Works Total: <b>9,525.24</b>
				General Fund Total: <b>44,828.24</b>
<b>Water &amp; Sewer Fund:</b>				
5006070	Al Warren Oil Co, INC	Diesel Fuel	1,087.32	
5006070	Al Warren Oil Co, INC	Village Fuel Purchase	291.91	
5006070	Clean Sweep	Hourly Waste Haul, Water Main	143.75	FY19
5006070	Comed	107A Rt 25 PRV Well 1	75.20	
5006070	Comed	1613 Rt 34 Booster 2	178.92	
5006070	Comed	3523 Rt 34 Booster 1	28.96	

**Village of Oswego  
Bill List  
June 18, 2019**

<u>Fund/Department:</u>	<u>Vendor Name:</u>	<u>Description:</u>	<u>Amount:</u>	<u>Department Totals:</u>
5006070	Comed	405A Chicago Rd Pump Valve Well 2	21.54	
5006070	Illinois Collection Services	Collection Services	36.37	FY19
5006070	Metropolitan Industries	Emergency Replacement Pump	4,924.00	
5009999	Presnell, Danny	Refund Overpayment of Utility Bill	841.86	
5006070	Third Millennium	Green Pay Transaction Fees-Jan-March 2019	1,051.20	FY19
			Water & Sewer Fund:	<u>8,681.03</u>
<b>Water &amp; Sewer Capital Fund:</b>				
5106070	Ferguson Waterworks	Water Meter Purchase	42,484.05	
5106070	Ferguson Waterworks	Water Meter Purchase	26,131.56	
5106070	Ferguson Waterworks	Water Meter Purchase	11,320.42	
5106070	Ferguson Waterworks	Water Meter Purchase	6,105.40	
			Water & Sewer Capital Fund:	<u>86,041.43</u>
<b>Capital Fund:</b>				
3003000	Gilbane Building Company	Construction Services #33	351,513.97	
			Capital Fund:	<u>351,513.97</u>
<b>Vehicle Fund:</b>				
6001000	Napa Auto Parts	Shop Vehicle Two Post Lift	19,868.62	
			Vehicle Fund:	<u>19,868.62</u>
<b>Special Events Fund:</b>				
2302000	Champion Fencing	Fencing - Wine on the Fox	2,376.00	
			Special Events Fund:	<u>2,376.00</u>
<b>Subdivision Escrow Fund:</b>				
9100000	Oswego Comm Unit School Dist 308	Land Cash/Transition Fees	46,942.95	
9100000	Oswego Comm Unit School Dist 308	Land Cash/Transition Fees	67,424.81	
9100000	Oswego Fire Protection District	Transition Fees	2,547.09	
9100000	Oswego Public Library District	Transition Fees	2,481.50	
9100000	Oswegoland Park District	Land Cash/Transition Fees	44,562.67	
9100000	Oswegoland Park District	Land Cash/Transition Fees	3,745.62	
			Sub Escrow Fund:	<u>167,704.64</u>
<b>Agency Fund:</b>				
			Agency Fund:	<u>-</u>
<b>TIF Fund:</b>				
2503500	Robinson Engineering	17-R0347 Reserve at Hudson Crossing	154.00	
2503500	Robinson Engineering	17-R0416 Potter's Place	175.00	
2503500	Rubino Engineering, INC	Engineering-Adams St Improvements	4,000.00	
2503500	Shodeen Group, LLC	Reserve at Hudson Crossing	251,909.45	
			TIF Fund:	<u>256,238.45</u>
<b>Other General Fund:</b>				
1009999	Illinois State Police	Sex Offender Registration Fee	90.00	FY19
1009999	Office of Il Attorney General	Sex Offender Registration Fee	90.00	FY19
1009999	Treasurer of State of Illinois	Sex Offender Registration Fee	30.00	FY19
1000000	Trustmark	Voluntary Insurance	65.71	
1000000	Trustmark	Voluntary Insurance	463.00	
1000000	Trustmark	Voluntary Insurance	1,632.96	
			Other General Fund:	<u>2,371.67</u>
			Grand Total:	<u><u>939,624.05</u></u>

**AGENDA ITEM**

**MEETING TYPE:** Village Board  
**MEETING DATE:** June 18, 2019  
**SUBJECT:** Oswego Township Garage Special Use Permit  
**ACTION REQUESTED:**

Approve Ordinance Granting an Amended Special Use Permit for a Public Service Use located at 1150 Route 25.

**BOARD/COMMISSION REVIEW:**

The Planning and Zoning Commission held a public hearing on the proposed request at their June 13, 2019 Meeting. Staff will provide an update of the Commission’s review and recommendation at the June 18<sup>th</sup> Village Board meeting.

**ACTION PREVIOUSLY TAKEN:**

Date of Action	Meeting Type	Action Taken
10/10/2005	Village Board	Ordinance No. 05-132 Approving a special use permit for a Public Service Use

**DEPARTMENT:** Community Development  
**SUBMITTED BY:** Rod Zenner, Community Development Director  
**FISCAL IMPACT:** Not Applicable

**BACKGROUND:**

In 2005, the Village approved Ordinance #05-132 approving a Special Use Permit to allow for the development of a maintenance facility for Oswego Township at 1150 Route 25. Since that approval, the Township has completed the site containing a main building consisting of 9,600 square feet, two storage domes, and a gravel storage area. The plans attached identify the existing site plan and the proposed improvements.

**DISCUSSION:**

The petitioner is now requesting approval to amend the Special Use permit to allow for the construction on an additional storage building and to pave the gravel storage area. There is also an identified future 35-foot by 70-foot building identified along the front of the building. The potential future use of this building has not been specifically identified as it may be a potential improvement to the site after the existing paving and storage facility is constructed, but it would

likely be office or other support space as necessary in the future for the Township facility. As these improvements will increase the impervious surface, the petitioner will also increase the size of the stormwater detention facility.

Staff has reviewed the request and believes that the additional storage building is in keeping with the approved use of the site. The proposed paving of the rear gravel storage area will improve the site and reduce the potential for dust in the future. Staff also believes that the additional stormwater detention proposed would adequately address any storm water issues that could be generated by the increase in impervious surface. Therefore, staff recommends approval of the request.

**RECOMMENDATION:**

Staff is recommending approval of the Ordinance Granting an amendment to the Special Use Permit for 1150 Route 25 to allow for a Public Service Use as a maintenance facility for Oswego Township.

**ATTACHMENTS:**

- Ordinance
- Exhibit A: Legal Description
- Exhibit B: Map
- Exhibit C: Engineering Site Plan
- Plan and Zoning Commission Memo

**VILLAGE OF OSWEGO  
KENDALL AND WILL COUNTIES, ILLINOIS**

---

**ORDINANCE NO. 19 -- \_\_**

**AN ORDINANCE GRANTING AN AMENDMENT TO THE SPECIAL USE PERMIT FOR  
OSWEGO TOWNSHIP TO ALLOW FOR A PUBLIC SERVICE USE MAINTENANCE  
GARAGE LOCATED AT 1150 ROUTE 25 IN THE VILLAGE OF OSWEGO, KENDALL  
COUNTY, ILLINOIS**

(Oswego Township Garage)

---

**ADOPTED BY  
THE PRESIDENT AND BOARD OF TRUSTEES  
OF THE  
VILLAGE OF OSWEGO**

This \_\_ day of \_\_, 2019

Prepared by and Return to:  
Village of Oswego  
100 Parkers Mill  
Oswego, IL 60543

Published in this pamphlet form by authority of the President  
and Board of Trustees of the Village of Oswego on \_\_\_\_, 2019.

**AN ORDINANCE GRANTING AN AMENDMENT TO THE SPECIAL USE PERMIT FOR OSWEGO TOWNSHIP TO ALLOW FOR A PUBLIC SERVICE USE MAINTENANCE GARAGE LOCATED AT 1150 ROUTE 25 IN THE VILLAGE OF OSWEGO, KENDALL COUNTY, ILLINOIS**

(Oswego Township Garage)

---

**WHEREAS**, the Village of Oswego (“Village”) has a population of more than 25,000 and is therefore a “Home Rule Unit” under the 1970 Illinois Constitution; and

**WHEREAS**, the Illinois Constitution of 1970 provides that a Home Rule Unit may exercise any power and perform any function pertaining to its government and affairs, including but not limited to the power to regulate for the protection of the public health, safety, morals and welfare; to license, to tax; and to incur debt; and

**WHEREAS**, the Village has in full force and effect a codified set of those ordinances of the Village which are of a general and permanent nature, which said codified set is known and designated as the Village Code of the Village of Oswego, as amended; and

**WHEREAS**, the Special Use Permit for the Oswego Township Garage located at 1150 Route 25 was approved on October 10, 2005 by Ordinance No. 05-132 (Document No. 05-33752); and

**WHEREAS**, Oswego Township has submitted an application to allow for an amendment to the Special Use Permit to allow for the construction of additional structures and improvements; and

**WHEREAS**, the property is currently zoned R-1 Single Family Residence District and improved with a maintenance garage; and

**WHEREAS**, a Public Hearing was held on June 13, 2019 by the Planning and Zoning Commission, who accepted the findings of fact and recommended approval of the Special Use Permit; and

**WHEREAS**, the President and Board of Trustees make the following findings of fact:

1. The proposed building or use at the particular location requested is necessary or desirable to provide a service or a facility which is in the best interest of the public convenience and will contribute to the general welfare of the neighborhood or community.

*Response: The proposed amendment to the Special Use permit to construct 1-2 buildings and to pave the gravel storage area are consistent with the original Special Use permit for the types of uses proposed.*

2. The proposed building or use will not have a substantial or undue adverse effect upon adjacent property, the character of the neighborhood, traffic conditions, utility facilities and other matter affecting the public health, safety, and general welfare.

*Response: The proposed changes will enclose equipment and materials from the elements. The pavement addition will reduce dust that could be generated by the gravel storage area. The additional stormwater detention will provide adequate storage for the proposed improvements.*

3. The proposed building or use will be designed, arranged and operated so as to permit the development and use of neighboring property in accordance with the applicable district regulations.

*Response: The proposed changes will be used consistent to the previously approved Special Use permit for the property for a maintenance facility.*

4. The proposed building or use has been considered in relation to the goals and objectives of the Official Plan of the Village.

*Response: The proposed buildings and additions are consistent with the long-established uses of the site.*

5. There shall be reasonable assurance that the proposed building or use will be completed and maintained in a timely manner, if authorized.

*Response: The proposed changes have been accounted for in the Township's budget process and improvements are anticipated for the near future.*

and find it appropriate to grant the Major Amendment as presented to the Planning and Zoning Commission.

**NOW, THEREFORE, BE IT ORDAINED BY THE VILLAGE PRESIDENT AND BOARD OF TRUSTEES OF THE VILLAGE OF OSWEGO, KENDALL AND WILL COUNTIES, ILLINOIS IN THE EXERCISE OF THEIR HOME RULE, STATUTORY AND OTHER POWERS, as follows:**

**Section 1:** That the recitals set forth above are incorporated here by reference, and the application for a Special Use Permit for a Public Service Use for the Oswego Township Garage is approved and that the Village Clerk is hereby directed to record with the Kendall County Clerk a certified copy of this Ordinance, together with an accurate map of the property hereby rezoned and made a part hereof, identified and enumerated on the following exhibits:

Exhibit "A"- Legal Description

Exhibit "B"- Location Map

Exhibit "C" – Engineering Site Plan

**Section 2: SEVERABILITY**

This ordinance and every provision thereof shall be considered severable. If any section, paragraph, subdivision, clause, sentence or provision of this Ordinance shall be adjudged by any Court of competent



jurisdiction to be invalid, such judgment shall not affect, impair, invalidate or nullify the remainder thereof, which remainder shall remain and continue in full force and effect.

**Section 3: REPEALER**

All ordinances or parts of ordinances in conflict herewith are hereby repealed to the extent of such conflict.

**Section 4: EFFECTIVE DATE**

This Ordinance shall be in full force and effect immediately upon its passage, approval and publication in this pamphlet form which is hereby authorized, as provided by law.

**PASSED** by the Board of Trustees of the Village of Oswego, Kendall and Will Counties, Illinois this \_\_\_ day of \_\_\_\_ 2019.

JAMES MARTER \_\_\_\_\_

LUIS PEREZ \_\_\_\_\_

TERRY OLSON \_\_\_\_\_

JUDY SOLLINGER \_\_\_\_\_

PAM PARR \_\_\_\_\_

BRIAN THOMAS \_\_\_\_\_

**APPROVED** by me, Troy Parlier, as President of the Village of Oswego, Kendall and Will Counties, Illinois this \_\_\_ day of \_\_\_\_\_ 2019.

\_\_\_\_\_  
TROY PARLIER, VILLAGE PRESIDENT

\_\_\_\_\_  
TINA TOUCHETTE, VILLAGE CLERK

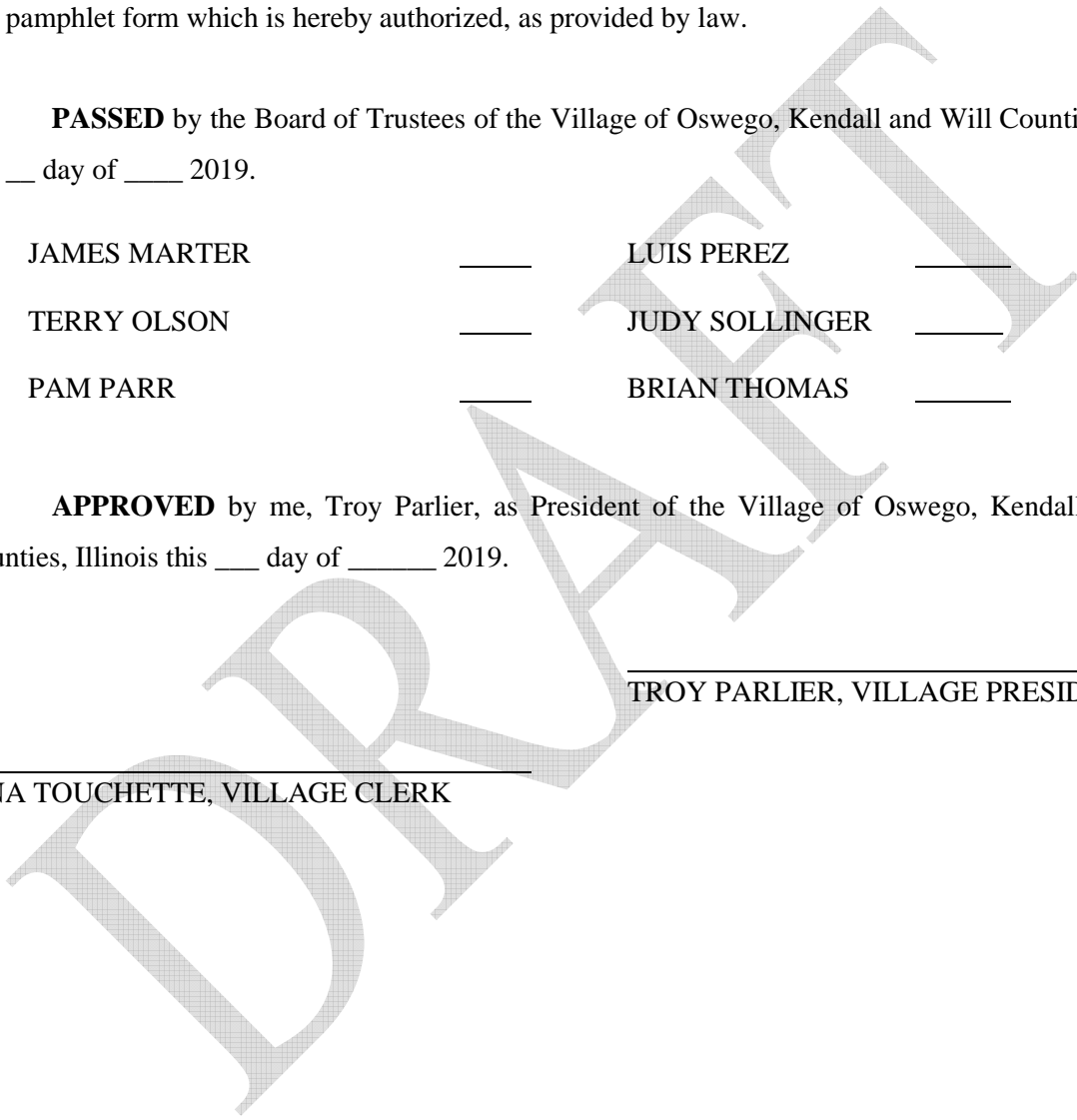

STATE OF ILLINOIS        )  
  )  
COUNTY OF KENDALL     )

SS

**CLERK'S CERTIFICATE**  
**(ORDINANCE)**

I, Tina Touchette, the duly qualified and acting Village Clerk of the Village of Oswego, Kendall and Will Counties, Illinois, do hereby certify that I am the keeper of its books and records and that the attached hereto is a true and correct copy of an Ordinance entitled:

**AN ORDINANCE GRANTING AN AMENDMENT TO THE SPECIAL USE PERMIT FOR  
OSWEGO TOWNSHIP TO ALLOW FOR A PUBLIC SERVICE USE MAINTENANCE  
GARAGE LOCATED AT 1150 ROUTE 25 IN THE VILLAGE OF OSWEGO, KENDALL  
COUNTY, ILLINOIS**

which Ordinance was duly adopted by said Board of Trustees at a meeting held on the \_\_ day of \_\_\_\_\_ 2019, approved by the Village President on the \_\_ day of \_\_\_\_\_ 2019 and thereafter published in pamphlet form to the extent required by law.

I do further certify, in my official capacity, that a quorum of said Board of Trustees was present at said meeting and that the Board complied with all requirements of the Illinois Open Meetings Act.

IN WITNESS WHEREOF, I have hereunto set my hand this \_\_ day of \_\_\_\_\_ 2019.

\_\_\_\_\_  
Tina Touchette, Village Clerk  
Village of Oswego

(Seal)

**Exhibit A**  
**Legal Description**

THAT PORTION OF THE NORTH HALF OF SECTION 8, TOWNSHIP 37 NORTH, RANGE 8 EAST OF THE THIRD PRINCIPAL MERIDIAN, DESCRIBED AS FOLLOWS:  
COMMENCING AT A POINT WHICH IS 858 FEET WEST AND 177.44 FEET NORTH OF THE SOUTHEAST CORNER OF SAID NORTHEAST QUARTER OF SECTION 8; THENCE NORTH 82° 30'00" WEST 1422.74 FEET TO THE WESTERLY RWIGHAT-OYF-LINE OF THE CHICAGO, BURLINGTON AND QUINCY RAILROAD COMPANY; THENCE CONTINUING NORTH 80°20'30" WEST 686.20 FEET TO THE CENTER LINE OF ILLINOIS STATE ROUT NO. 25, BEING THE EASTERLY LINE OF LAND CONVEYED TO THE FOX VALLEY PEASURE DRIVE AND PARK DISTRICT BY DEED RECORD BOOK 111, PAGES 343 AND 344 ((PARCEL 3)) AT THE KENDALL COUNTY RECORDER'S OFFICE); THENCE NORTH 119°58' W EST 608.62 FEET ALONG SAID CENTERLINE TO AN ANGLE POINT; THENCE NORTH 116°12' W EST 536.92 FEET FOR THE POINT OF BEGINNING; THENCE SOUTH 80°045' EAST 893.03 FEET; THENCE NORTH 0171°08' EAST 250.00 FEET TO AN OLD CLAIM LINE OF LANDS FORMERLY BELONGING TO C. W. BENNITT AND J. WORMLEY ( AS PER SLOT 318 A AT THE KENDALL COUNTY RECORDER'S OFFICE); THENCE NORTH 80°045' WEST 929.69 FEET ALONG SAID CLAIM TO SAID CENTERLINE OF ILLINOIS STATE ROUTE NO. 25; THENCE SOUTH 116°12' EAST ALONG SAID CENTERLINE 252.75 FEET TO THE POINT OF BEGINNING IN THE TOWNSHIP OF OSWEGO, KENDALL COUNTY, ILLINOIS.

# Oswego Township Garage



Line 4, 2019

 Parcels

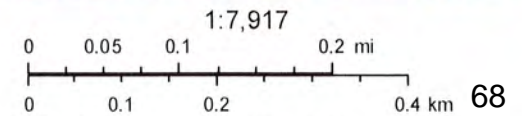

Esri, HERE, Garmin, (c) OpenStreetMap contributors, and the GIS user community  
Kendal County Illinois GIS  
Copyright © 2011 Village of Oswego

# ENGINEERING PLANS FOR OSWEGO TOWNSHIP SITE IMPROVEMENTS

SECTION 8, TOWNSHIP 37 NORTH, RANGE 8 EAST

1150 ROUTE 25  
OSWEGO, IL 60543  
KENDALL COUNTY  
MARCH, 2018

LEGEND	
---	PROPERTY BOUNDARY
---	EXISTING CONTOUR LINE
---	EXISTING STORM SEWER
---	EXISTING SANITARY SEWER LINE
---	EXISTING WATERMAIN
---	EXISTING UNDERGROUND ELECTRIC
---	EXISTING OVERHEAD ELECTRIC
---	EXISTING GAS SERVICE
---	EXISTING TELEPHONE
---	PROPOSED CONTOUR LINE
---	PROPOSED WATERMAIN
---	PROPOSED STORM SEWER
---	PROPOSED SANITARY SEWER LINE
---	PROPOSED GREASE SERVICE LINE
---	PROPOSED VENT LINE
---	EXISTING FENCELINE
---	PROPOSED SILT FENCE
•	EXISTING SPOT SHOT
•	PROPOSED SPOT GRADE
WATER:	EXIST PROP
---	B-BOX
•	HYDRANT
•	VALVE
•	VALVE VAULT
STORM	INLET-CURB
•	INLET OR MANHOLE
▽	FLARED END SECTION
SANITARY:	CLEANOUT
•	MANHOLE
⊗	R.O.W. MONUMENT
•	PROPERTY PIN
▲	P.K. NAIL
■	CHISELED MARK
■	BENCHMARK
•	HUB & TACK
•	SOIL BORING
▽	OVERLAND RELIEF
→	FLOW DIRECTION
○	UTILITY POLE
---	GUY WIRE LOC.
■	UTIL CABINET
■	UTIL PEDESTAL
•	LIGHT POLE
•	TRAFFIC SIGNAL
•	ELECTRIC VAULT
•	GAS VALVE

### INDEX TO SHEETS

- 1 COVER SHEET
- 2 EXISTING CONDITIONS & EROSION CONTROL PLAN
- 3 CIVIL SITE PLANS
- 4 GENERAL NOTES & DETAILS

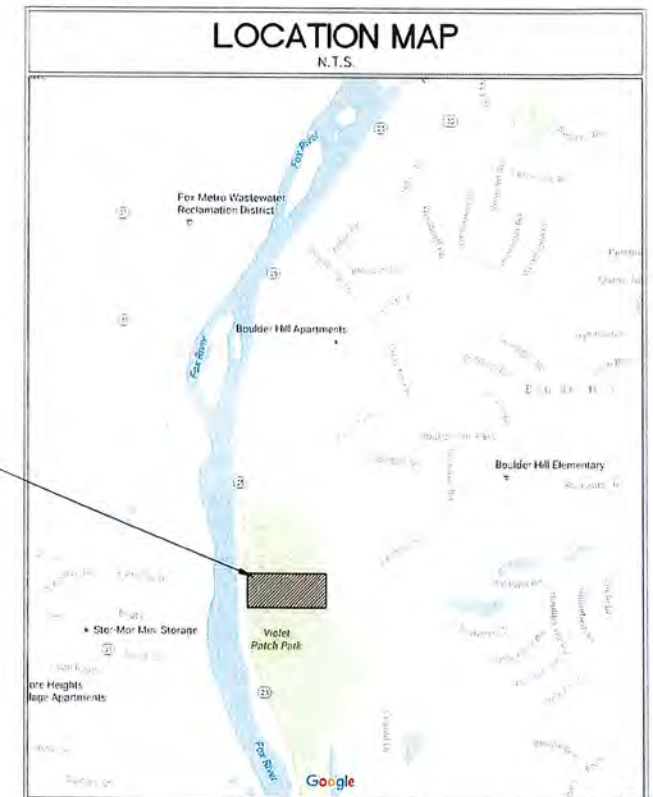

### BENCHMARKS:

- RM 25 A CHISELED CROSS ON NORTH END OF 12" CORRUGATED METAL PIPE ON EAST SIDE OF STATE ROUTE 25, LOCATED ABOUT 1.1 MILES SOUTH FROM INTERSECTION WITH STATE ROUTE 30.  
ELEV = 615.56
- LOCAL BM 1 PK NAIL IN ASPHALT BIKEPATH LOCATED 150' NORTH OF ENTRANCE INTO VIOLET PATCH PARK ALONG THE WEST SIDE OF ROUTE 25.  
ELEV = 606.16

### PLANS PREPARED FOR:

OSWEGO TOWNSHIP  
HIGHWAY DEPARTMENT  
1150 ROUTE 25  
OSWEGO, IL 60543  
PHONE: 630.264.4587

### CIVIL ENGINEER:

TEBRUGGE ENGINEERING  
410 E CHURCH ST - SUITE A  
SANDWICH, ILLINOIS 60548  
(815) 786-0195

INFO@TEBRUGGEENGINEERING.COM  
WWW.TEBRUGGEENGINEERING.COM



Know what's below.  
Call before you dig.

Contractor and/or sub-contractors shall verify locations of all underground utilities prior to digging. Contact J.U.L.I.E. (Joint Utility Locating) Excavations at 1-800-892-0125 or dial 811.

**UTILITY STATEMENT**  
I, JOHN J. TEBRUGGE, A LICENSED PROFESSIONAL ENGINEER OF ILLINOIS, HEREBY CERTIFY THAT THESE PLANS HAVE BEEN PREPARED UNDER MY PERSONAL DIRECTION BASED ON AVAILABLE DOCUMENTS AND FIELD MEASUREMENTS FOR THE EXCLUSIVE USE OF THE CLIENT NOTED HEREON.  
GIVEN UNDER MY HAND & SEAL THIS 28TH DAY OF MARCH 2019

PROFESSIONAL ENGINEER'S CERTIFICATION  
STATE OF ILLINOIS, COUNTY OF KENDALL

I, JOHN J. TEBRUGGE, A LICENSED PROFESSIONAL ENGINEER OF ILLINOIS, HEREBY CERTIFY THAT THESE PLANS HAVE BEEN PREPARED UNDER MY PERSONAL DIRECTION BASED ON AVAILABLE DOCUMENTS AND FIELD MEASUREMENTS FOR THE EXCLUSIVE USE OF THE CLIENT NOTED HEREON.

GIVEN UNDER MY HAND & SEAL THIS 28TH DAY OF MARCH 2019



*John J. Tebrugge*  
ILLINOIS REGISTERED PROFESSIONAL ENGINEER  
NO. 0062-041828 EXPIRES NOV. 30, 2019

COPYRIGHT © 2019 BY TEBRUGGE ENGINEERING. ALL RIGHTS RESERVED. NO PART OF THESE CIVIL ENGINEERING PLANS MAY BE REPRODUCED, EITHER WHOLLY OR IN PART, BY ANY MEANS, INCLUDING PHOTOCOPYING, RECORDING, OR BY ANY INFORMATION STORAGE AND RETRIEVAL SYSTEM, WITHOUT THE WRITTEN PERMISSION OF TEBRUGGE ENGINEERING.

EXHIBIT  
C page 1 of 4

NO.	DATE	REVIEW
1	2.8.18	OSWEGO TOWNSHIP REVIEW LETTER DATED 1.11.18
2	3.12.18	OSWEGO TOWNSHIP REVIEW LETTER DATED 3.6.18
3	3.6.19	OWNER CHANGES, NEW BUILDING & PAVING
4	3.28.19	OSWEGO TOWNSHIP REVIEW LETTER 3.21.19

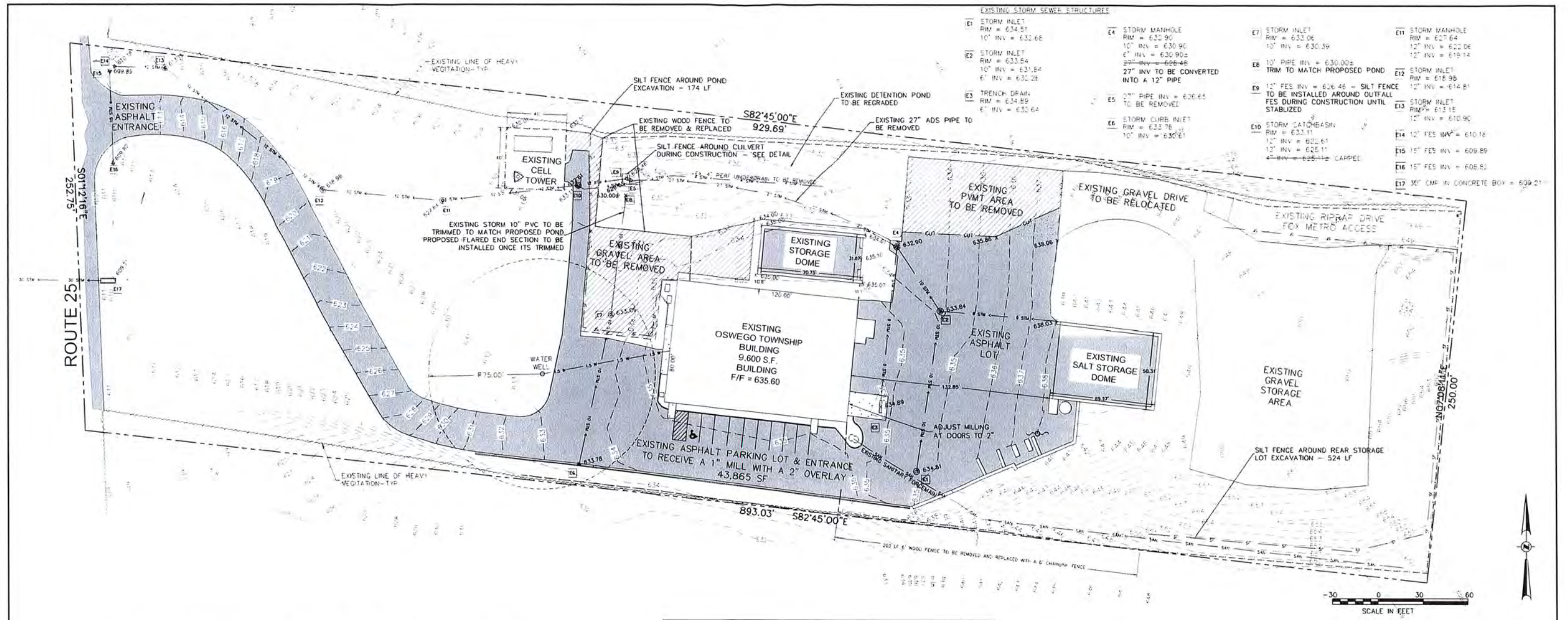

PERMANENT EROSION CONTROL FABRIC BY NORTH AMERICAN GREEN - TYPE NAG SC150 SHALL BE APPLIED TO ALL SLOPES 4:1 OR GREATER. FOLLOW MANUFACTURER SPECIFICATIONS FOR INSTALLATION. THE CONTRACTOR SHALL NOTE ALL AREAS WHERE NAG SC150 HAS BEEN INSTALLED RELATIVE TO AS-BUILT GRADES AND FURNISH THESE BOUNDARIES TO THE CIVIL ENGINEER UPON REQUEST.

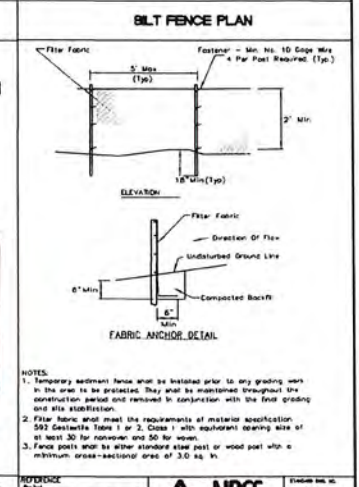
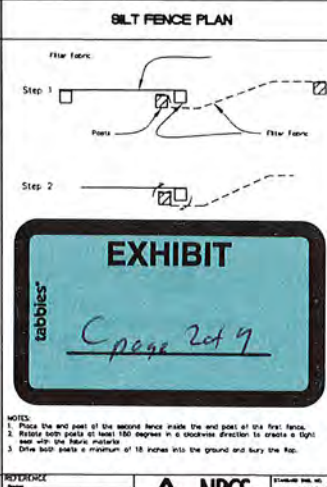
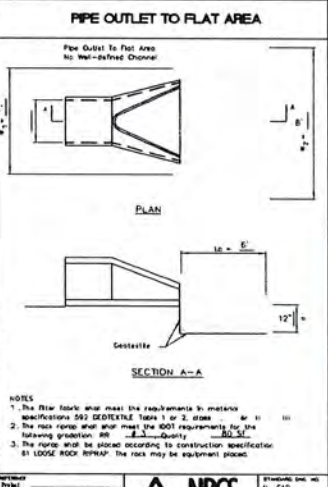
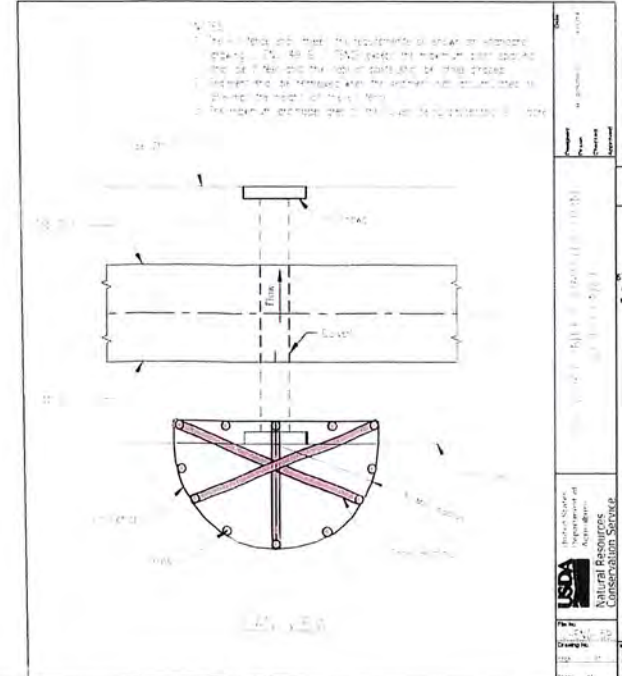
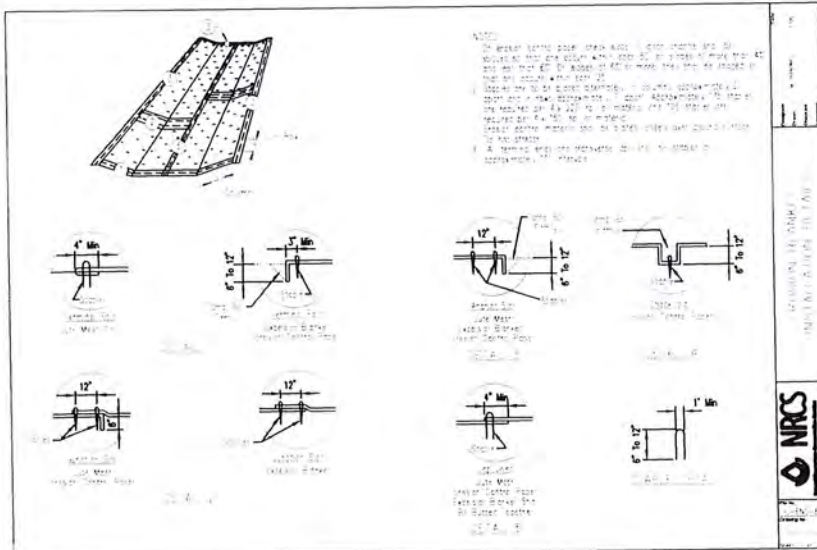

**EXHIBIT**  
*C page 2 of 9*

**TEBRUGGE ENGINEERING**  
 4101 CHURCH STREET, SUITE A, SANDWICH, IL 60548  
 PHONE (815) 766-0099 TEBRUGGEENGINEERING.COM

NO.	DATE	NOTES
1	2.8.18	OSWEGO TOWNSHIP REVIEW LETTER DATED 1.11.18
2	3.12.18	OSWEGO TOWNSHIP REVIEW LETTER DATED 3.6.18
3	3.6.19	OWNER CHANGES, NEW BUILDING & PARKING
4	3.28.19	OSWEGO TOWNSHIP REVIEW LETTER 3.21.19

PREPARED FOR  
**OSWEGO TOWNSHIP**  
 1150 ROUTE 25 OSWEGO, IL 60543

**OSWEGO TOWNSHIP ROAD DISTRICT**  
 EXISTING CONDITIONS & DEMOLITION PLAN

PROJECT NO. 16 105 06 SHEET NO. **2**  
 SCALE: 1" = 30'  
 DATE: 1.5.16 OF 4 SHEETS

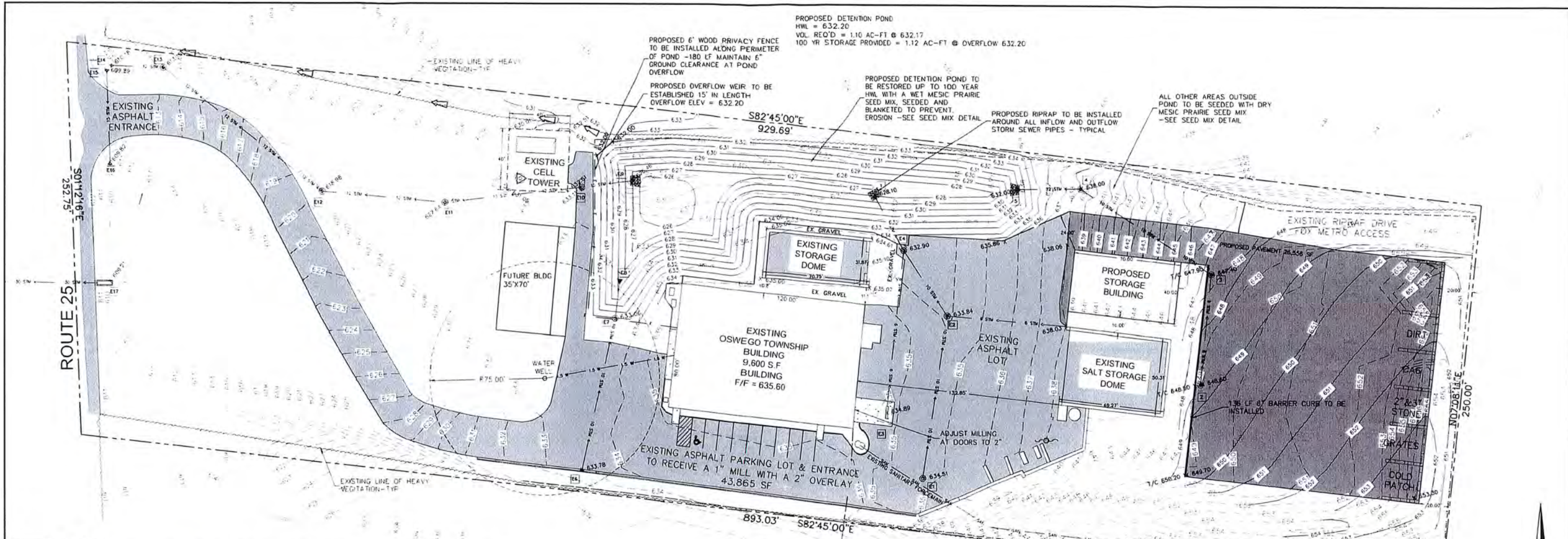

**EARTHWORK AND GRADING**

1. ALL FILL PLACED UNDER THE PROPOSED PAVEMENT SHALL CONFORM TO SECTION 205 OF THE REFERENCED IDOT "STANDARD SPECIFICATIONS". THIS INCLUDES (BUT IS NOT LIMITED TO) THE REMOVAL OF TOPSOIL FROM FILL AREAS AND THE PROPER COMPACTION OF FILL.
2. THE SUBGRADE FOR ROADWAYS AND SIDEWALKS SHALL BE FREE OF UNSUITABLE MATERIAL AND SHALL BE COMPACTED TO A MINIMUM OF 95% OF MODIFIED PROCTOR DRY DENSITY. TESTING FOR COMPACTION SHALL BE THE RESPONSIBILITY OF THE DEVELOPER/CONTRACTOR AND THE VILLAGE SHALL BE PROVIDED WITH A COPY OF THE TESTING REPORT.
3. ALL STORMWATER MANAGEMENT FACILITY EMBANKMENT SLOPES SHALL NOT EXCEED A MAXIMUM SLOPE OF 4:1.
4. ALL EARTHWORK SHALL RESULT IN A FINAL BLACK DIRT PLACEMENT WITHIN 0.10 FEET OF THE APPROVED PLAN WITH RECORD "AS-BUILT" DRAWINGS (AND STAGE VS STORAGE CALCULATIONS WHERE APPROPRIATE) PREPARED BY THE DESIGN ENGINEER OF RECORD AND SUBMITTED FOR VILLAGE REVIEW AND APPROVAL.
5. ALL EXCESS EARTHWORK MATERIALS, IF NOT TO BE UTILIZED AS FILL MATERIAL, SHALL BE COMPLETELY REMOVED FROM THE SITE AND DISPOSED OF OFF-SITE BY THE DEVELOPER/CONTRACTOR UNLESS OTHERWISE DIRECTED BY THE VILLAGE ENGINEER.

**RESTORATION AND LANDSCAPING**

1. BACKFILL ALL OVER-DUG OR EXCAVATED AREAS MANUALLY OR MECHANICALLY WITH PULVERIZED TOPSOIL. (SOURCE TO BE APPROVED BY TOWNSHIP OR ENGINEERS REPRESENTATIVE.)
2. THE COVER CROP MATRIX WILL BE SEEDING AND MATTED WITH 100% BIODEGRADABLE SOIL EROSION CONTROL BLANKET THROUGHOUT THE STORM WATER DETENTION AREAS AND TEMPORARY IMPACT AREAS IMMEDIATELY AFTER PROJECT COMPLETION. ALL SEEDING SHALL BE HAND BROADCAST AT THREE TIMES THE DRILL SPEED RATE. THE COVER CROP MATRIX WILL BE PLANTED THROUGHOUT THE TEMPORARY IMPACT AREA IMMEDIATELY AFTER PROJECT COMPLETION TO PREVENT EROSION IF CONDITIONS ARE NOT CONDUCTIVE FOR NATIVE SPECIES SEEDING. PERMANENT NATIVE SPECIES SHALL BE DORMANT SEEDING OR SEEDING DURING THE FIRST AVAILABLE GROWING SEASON AT THE APPROPRIATE TIME AND CONDITIONS FOR SUCH PLANTINGS. THE SEED WILL BE LIGHTLY RAKED IN, ROLLED AND WATERED.
3. ALL PLANTING AREAS SHALL HAVE AT LEAST 12" OF CLEAN UN-COMPACTED TOPSOIL. GRADED PORTIONS OF THE PLANTING AREAS THAT DO NOT EXPOSE SUITABLE PLANTING MEDIUM SHALL BE OVER EXCAVATED AND RE-SPREAD WITH 12" OF TOPSOIL. THE SUBSOIL SHALL BE LOOSENED AND TOPSOIL APPLIED TO MINIMIZE COMPACTION. ALL CLUMPS, STONES AND DEBRIS SHALL BE REMOVED AND DISPOSED OF LEGALLY OFF-SITE. THE TOP 2" OF THE SOIL SHALL BE RAKED PRIOR TO SEEDING WITHIN THE PLANTING AREAS.
4. SEED BLENDS:
  - A) USE WET MESIC PRAIRIE SEED MIX IN AREA BELOW THE 100 YEAR HIGH WATER LEVEL OF 632.00
  - B) USE DRY MESIC PRAIRIE SEED MIX IN ALL OTHER DISTURBED AREAS ABOVE THE 100 YEAR HIGH WATER LEVEL AROUND THE POND.
5. ALL MATERIALS, WORK METHOD, EQUIPMENT AND SCHEDULING OF WORK TO BE APPROVED BY TOWNSHIP OR ENGINEERS REF PRIOR TO COMMENCEMENT OF LANDSCAPE RESTORATION WORK.

**DETENTION POND MANAGEMENT, MONITORING & MAINTENANCE**

1. DETENTION POND VEGETATION SHALL BE MONITORED FOR A 3 YEAR PERIOD. AN ANNUAL REPORT SHALL BE PREPARED AND SUBMITTED TO THE VILLAGE OF OSWEGO BEFORE JANUARY 31ST FOR EACH YEAR OF MONITORING. THE REPORT SHALL DESCRIBE THE EXISTING CONDITION OF THE VEGETATION, OUTLINE MEETING THE PERFORMANCE STANDARDS FOR EACH YEAR, INCLUDE PHOTOGRAPHS AND RECOMMENDATIONS FOR ADDITIONAL MANAGEMENT ACTIVITIES IF SITE IS NOT MEETING THE YEARLY PERFORMANCE STANDARDS.
2. PERFORMANCE STANDARDS FOR 3 YEARS MONITORING:
  - A. BY THE END OF THE THIRD GROWING SEASON, AT LEAST 50% OF THE VEGETATIVE COVERAGE (AS MEASURED BY AERIAL COVERAGE) WILL CONSIST OF SEEDING / PLANTED SPECIES. THE PLANTED AREA SHALL EXHIBIT AT LEAST THE FOLLOWING AT THE END OF EACH GROWING SEASON: YEAR 1 - 10% AND YEAR 2 - 25%.
  - B. BY THE END OF THE THIRD GROWING SEASON, AT LEAST 75% OF THE PLANTED AREAS MUST CONTAIN NATIVE, NON-INVASIVE PERENNIAL SPECIES AS MEASURED BY AERIAL COVERAGE. THE PLANTED AREA SHALL EXHIBIT AT LEAST THE FOLLOWING AT THE END OF EACH GROWING SEASON: YEAR 1 - 10% AND YEAR 2 - 25%.
  - C. NONE OF THE THREE MOST DOMINANT SPECIES WITHIN THE PLANTED AREAS SHALL BE NON-NATIVE OR INVASIVE SPECIES, INCLUDING BUT NOT LIMITED TO: CATTAIL (TYPHA SPP.), REED CANARY GRASS (PHALARIS ARUNDINACEA), PURPLE LOOSESTRIFE (LYTHRUM SALICARIA), COMMON REED (PHRAGMITES AUSTRALIS), CANADA THISTLE (CIRSIIUM ARVENSE), SANDBAR WILLOW (SALIX ERIODIA), KENTUCKY BLUE GRASS (POA PRATENSIS), AND WHITE SWEET CLOVER (MELILOTUS ALBA).
  - D. NO MORE THAN 0.5 SQUARE METERS IN SIZE SHALL BE DEVOID OF VEGETATION AT ANY TIME.
  - E. 100% OF THE PLANTED TREES AND SHRUBS SHALL BE ALIVE, IN HEALTHY CONDITION, AND REPRESENTATIVE OF THE INDIVIDUAL SPECIES AT THE END OF EACH GROWING SEASON.
  - F. PRESCRIBED BURNING SHALL BE COMPLETED IN EARLY SPRING OR LATE FALL AND SHALL BE PERFORMED BY PROFESSIONALS TRAINED IN WILDFIRE MANAGEMENT.
  - G. MATURE PRAIRIE SHALL BE BURNED EVERY 2-4 YEARS BUT NOT CONDUCTED BEFORE THIRD GROWING SEASON TO ENSURE THE EROSION CONTROL BLANKET HAS ONLY WATER SOLUBLE HERBICIDES.
  - H. HERBICIDES MAY BE APPLIED TO TARGET SPECIFIC SPECIES BUT APPLICATION TIMING SHOULD BE DETERMINED BASED ON FLOWERING TIME OF TARGET SPECIES. USE ONLY WATER SOLUBLE HERBICIDES.
3. MAINTENANCE:
  - A. HIGH MOWING SHALL BE CONDUCTED TO PREVENT WEEDS FROM SHADING PRAIRIE SEEDLINGS.
  - B. MOWING SHALL BE COMPLETED IN LATE SPRING/ EARLY SUMMER AND/OR LATE FALL WHEN PRESCRIBED BURNING IS NOT POSSIBLE.
  - C. MOWING HEIGHT SHALL BE 6-8 INCHES.
  - D. MOWING SHALL NOT BE COMPLETED DURING THE SUMMER MONTHS WHEN NATIVE PRAIRIE PLANTS ARE FLOWERING.

**EXISTING STORM SEWER STRUCTURES**

- |     |  |     |   |
|-----|--|-----|---|
| E1  | STORM INLET<br>RIM = 634.51<br>10" INV = 632.68  | E11 | STORM MANHOLE<br>RIM = 627.64<br>12" INV = 622.06<br>12" INV = 619.14 |
| E2  | STORM INLET<br>RIM = 633.84<br>10" INV = 631.84<br>6" INV = 632.26   | E12 | STORM INLET<br>RIM = 618.98<br>12" INV = 614.81                       |
| E3  | TRENCH DRAIN<br>RIM = 634.89<br>6" INV = 632.64  | E13 | STORM INLET<br>RIM = 613.15<br>12" INV = 610.90                       |
| E4  | STORM MANHOLE<br>RIM = 632.90<br>10" INV = 630.90<br>6" INV = 630.90+<br>2" INV = 626.46                                 | E14 | 12" FES INV = 610.18  |
|     | PROPOSED 40 LF 12" ADS PIPE @ 1.0%<br>12" INV = 628.50   | E15 | 15" FES INV = 609.89  |
| E6  | STORM CURB INLET<br>RIM = 633.78<br>10" INV = 630.61   | E16 | 15" FES INV = 608.52  |
| E7  | STORM INLET<br>RIM = 633.06<br>10" INV = 630.39  | E17 | 30" CMP IN CONCRETE BOX = 609.21                                      |
| E8  | 10" PIPE INV = 630.00+<br>INSTALL FLARED END SECTION WITH RIPRAP   |     |   |
| E9  | 12" FES INV = 628.46   |     |   |
| E10 | STORM CATCHBASIN<br>OUTFALL STRUCTURE<br>RIM = 633.11<br>12" INV = 622.61<br>12" INV = 625.11<br>4" INV = 625.11+ CAPPED |     |   |

**WET MESIC PRAIRIE MIX**

Scientific Name	Common Name
<i>Artemisia alba</i>	RED TOP
<i>Artemisia vulgaris</i>	SCUDGRASS
<i>Artemisia cana</i>	ANNUAL RYE
<i>Lolium multiflorum</i>	ANNUAL RYE
<i>Carex comosa</i>	BRISTLY SEDGE
<i>Echinochloa crusgalli</i>	BARNYARD GRASS
<i>Echinochloa crusgalli</i>	MARSH SPIKE GRASS
<i>Tripsacis dactyloides</i>	RED-ROOTED SPIKE RUSH
<i>Juncus effusus</i>	COMMON RUSH
<i>Scirpus americanus</i>	RICK CUT GRASS
<i>Scirpus americanus</i>	HARD-STEMMED BELURUSH
<i>Scirpus americanus</i>	RIVER BELURUSH
<i>Scirpus americanus</i>	CHARMAKERS RUSH
<i>Scirpus americanus</i>	GREAT BELURUSH
<i>Scirpus americanus</i>	COMMON BUR RIEDE
<i>Scirpus americanus</i>	PRAIRIE CORN GRASS

SEE EXISTING OUTFALL RESTRICTOR DETAIL ON THIS SHEET (BOTTOM RIGHT CORNER) FOR ALL PROPOSED 2 YR & 100 YR RESTRICTOR INFORMATION.

**DRY MESIC PRAIRIE MIX**

Scientific Name	Common Name
<i>Artemisia scopulorum</i>	PURPLE GIANT HYSSOP
<i>Artemisia scopulorum</i>	TALL ANEMONE
<i>Artemisia scopulorum</i>	COLUMBINE
<i>Artemisia scopulorum</i>	JACK-IN-THE-PULPIT
<i>Artemisia scopulorum</i>	CALICO ASTER
<i>Artemisia scopulorum</i>	ARROW-LEAFED ASTER
<i>Artemisia scopulorum</i>	SHRUBS ASTER
<i>Artemisia scopulorum</i>	WHITE WINGED
<i>Artemisia scopulorum</i>	TAIL BELLEFLOWER
<i>Artemisia scopulorum</i>	YIRGIN'S BOWTIE
<i>Artemisia scopulorum</i>	PURPLE TOP WEEED
<i>Artemisia scopulorum</i>	GREAT ST. JOHN'S WORT
<i>Artemisia scopulorum</i>	INDIAN TORNBUD
<i>Artemisia scopulorum</i>	FOXGLOVE BEARD TONGUE
<i>Artemisia scopulorum</i>	SMOOTH SOLOMON'S SEAL
<i>Artemisia scopulorum</i>	HARRY POT
<i>Artemisia scopulorum</i>	YELLOW CORNFLOWER
<i>Artemisia scopulorum</i>	BLACK EYED SUSAN
<i>Artemisia scopulorum</i>	ROSEWEED
<i>Artemisia scopulorum</i>	FLATTERY FALSE SOLIDAGINA SEAL
<i>Artemisia scopulorum</i>	ZIGZAG GOLDENROD
<i>Artemisia scopulorum</i>	EARLY GOLDENROD
<i>Artemisia scopulorum</i>	DIRTY SPIDERWEED
<i>Artemisia scopulorum</i>	RED THRUWAX
<i>Artemisia scopulorum</i>	LATE PERSEUS GRASS
<i>Artemisia scopulorum</i>	WHITE VERNAIN
<i>Artemisia scopulorum</i>	PIERSBELL WEEED
<i>Artemisia scopulorum</i>	GOLDEN ALEXANDER

**PROPOSED STORM SEWER STRUCTURES**

1. 12" ADS FLARED END SECTION  
INV = 628.10
2. 2" STORM INLET  
RIM = 648.80  
8" INV = 645.43  
70 LF 8" SDR26 PVC @ 2.0%
3. 4" STORM CATCH BASIN  
RIM = 647.40  
10" S INV = 644.03  
10" NW INV = 638.64  
100 LF 10" SDR26 PVC @ 3.0%
4. 4" STORM CATCH BASIN  
RIM = 638.00  
10" SE INV = 635.64  
10" W INV = 632.64  
40 LF 12" SDR26 PVC @ 1.6%
5. 12" ADS FLARED END SECTION  
INV = 632.00

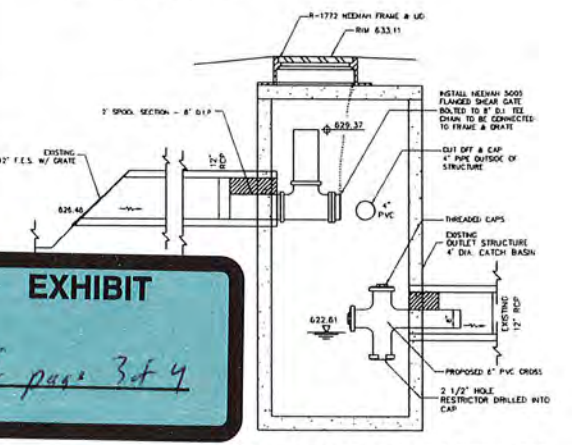

**EXHIBIT**  
C page 3 of 4

NO.	DATE	NOTES
1	2.8.18	OSWEGO TOWNSHIP REVIEW LETTER DATED 1.31.18
2	3.12.18	OSWEGO TOWNSHIP REVIEW LETTER DATED 3.6.18
3	3.6.19	TOWNSHIP CHANGES, NEW BUILDING & PARKING
4	3.28.19	OSWEGO TOWNSHIP REVIEW LETTER 3.21.19







## COMMUNITY DEVELOPMENT DEPARTMENT

100 Parkers Mill • Oswego, IL 60543 • (630) 554-3622  
Website: <http://www.oswegoil.org>

---

### STAFF REPORT

**DATE:** April 2, 2019

**TO:** Chairman and Planning and Zoning Commission

**FROM:** Rod Zenner, Community Development Director

**SUBJECT:** Staff Report for the June 13, 2019 Planning and Zoning Commission Meeting  
Oswego Township Maintenance Garage – Special Use Permit  
Project #1039.19

#### Applicant

Oswego Township

#### Requested Action

The applicant is requesting an amendment to the Special Use Permit for a public service to allow for an expansion of the existing maintenance facility.

#### Location, Existing Zoning and Land Use

The property is located at 1150 Route 25. The property is zoned R-1 Single Family Residence District and is improved with a maintenance facility.

#### Surrounding Zoning and Land Uses

North: A-1 Agricultural (Kendall County) - Park  
South: R-1 Single Family Residence District – Park  
East: R-1 Single Family Residence District - Park  
West: R-5 One Family Residential (Kendall County) – Single Family Residential

#### Relationship to Village Comprehensive Plan

The proposed use is not consistent with the Comprehensive Plan's designation of the area as "Parks Open Space" but is consistent with the current use of the site.

#### Donation Requirements

None.

#### Staff Analysis

In 2005, the Village approved Ordinance #05-132 approving a Special Use Permit to allow for the development of a maintenance facility for Oswego Township at 1150 Route 25. Since that approval, the Township has completed the site containing a main building consisting of 9,600 square feet, two storage domes, and a gravel storage area. The plans attached identify the

existing site plan and the proposed improvements.

The petitioner is now requesting approval to amend the Special Use permit to allow for the construction on an additional storage building and to pave the gravel storage area. There is also an identified future 35-foot by 70-foot building identified along the front of the building. The potential future use of this building has not been specifically identified as it may be a potential improvement to the site after the existing paving and storage facility is constructed, but it would likely be office or other support space as necessary in the future for the Township facility. As these improvements will increase the impervious surface, the petitioner will also increase the size of the stormwater detention facility.

Staff has reviewed the request and believes that the additional storage building is in keeping with the approved use of the site. The proposed paving of the rear gravel storage area will improve the site and reduce the potential for dust in the future. Staff also believes that the additional stormwater detention proposed would adequately address any storm water issues that could be generated by the increase in impervious surface. Therefore, staff recommends approval of the request.

### **Special Use Standards**

A Special Use Permit for the uses listed in each applicable zoning district may be granted and the applicable district regulations modified only if evidence is presented to establish that:

1. The proposed building or use at the particular location requested is necessary or desirable to provide a service or a facility which is in the best interest of the public convenience and will contribute to the general welfare of the neighborhood or community.

*The proposed amendment to the Special Use permit to construct 1-2 buildings and to pave the gravel storage area are consistent with the original Special Use permit for the types of uses proposed.*

2. The proposed building or use will not have a substantial or undue adverse effect upon adjacent property, the character of the neighborhood, traffic conditions, utility facilities and other matter affecting the public health, safety and general welfare.

*The proposed changes will enclose equipment and materials from the elements. The pavement addition will reduce dust that could be generated by the gravel storage area. The additional stormwater detention will provide adequate storage for the proposed improvements.*

3. The proposed building or use will be designed, arranged and operated so as to permit the development and use of neighboring property in accordance with the applicable district regulations.

*The proposed changes will be used consistent to the previously approved Special Use permit for the property for a maintenance facility.*

4. The proposed building or use has been considered in relation to the goals and objectives of the Official Plan of the Village.

*The proposed buildings and additions are consistent with the long-established uses of the site.*

5. There shall be reasonable assurance that the proposed building or use will be completed and maintained in a timely manner, if authorized.

*The proposed changes have been accounted for in the Township's budget process and improvements are anticipated for the near future.*

### **Recommendation**

**Staff recommends the Planning and Zoning Commission accept the findings of fact for the standards for a special use and recommend approval of the amended Special Use Permit for 1150 Route 25 to allow for a Public Service Use as a maintenance facility for Oswego Township.**



**AGENDA ITEM**

**MEETING TYPE:** Village Board

**MEETING DATE:** June 18, 2019

**SUBJECT:** 2019 Road Maintenance Project

**ACTION REQUESTED:**

Approval of a Supplemental Resolution for Maintenance Under the Illinois Highway Code in the Amount of \$99,600.00 of Motor Fuel Tax Funds in Fiscal Year 2020

Approval of a Resolution Authorizing the Execution of a Contract with D Construction, Coal City, IL in the Amount of \$828,722.62 for Maintenance of Various Streets

**BOARD/COMMISSION REVIEW:**

N/A

**ACTION PREVIOUSLY TAKEN:**

Date of Action	Meeting Type	Action Taken
4/9/2019	Village Board	Approved Resolution 19-R-21 for Maintenance Under the Illinois Highway Code in the Amount of \$800,000 of Motor Fuel Tax Funds in Fiscal Year 2020
4/9/19	Village Board	Approved Resolution 19-R-22 Authorizing the Execution of a Professional Engineering Services Contract with HR Green in an Amount of \$29,350.00 for Preliminary Engineering and 5% of the Final Construction Cost for the 2019 Pavement Resurface Program of Various Streets Utilizing Motor Fuel Tax Funds

**DEPARTMENT:** Public Works

**SUBMITTED BY:** Public Works Director/Village Engineer Jennifer M. Hughes, P.E., CFM

**FISCAL IMPACT:**

Motor Fuel Tax Fund – Acct. # 2006030- 572010 - \$800,000+\$99,600= \$899,600

**BACKGROUND:**

The Village Board authorized Staff to move forward with the design of the 2019 Road Resurface Project on April 9, 2019. HR Green completed the design.

**DISCUSSION:**

We opened three bids on May 9, 2019. Prices ranged from \$828,722.62 to \$930,888.00. D Construction of Coal City is the lowest responsible bidder. This company most recently completed a resurfacing project for the Village in 2015.

The preliminary schedule will be refined during the pre-construction meeting. The completion date is August 9, 2019.

The Village authorized the expenditure of \$800,000 in Motor Fuel Tax Funds by resolution on April 9, 2019. Due to the increase in the project costs, the Village will need to authorize an additional \$99,600. The Village expects to receive \$850,000 in FY 2020 MFT allotments distributed to the Village. We will transfer \$262,500 transfer to the Debt Service fund leaving an estimated Restricted Fund Balance at April 30, 2020 of \$980,660.

	<b>Initial Estimate</b>	<b>Adjusted By Bid</b>	<b>Difference</b>
<b>MFT</b>	\$800,000	\$899,508.75	\$99,508.75
<b>Other Village</b>	<u>\$0</u>	<u>\$ 0.00</u>	<u>\$ 0.00</u>
<b>Total Funds</b>	<b>\$800,000</b>	<b>\$899,508.75</b>	<b>\$99,508.75</b>
<b>Resurface – Various Locations</b>			
Phase 1 & 2 Engineering – 4%	\$29,350.00 <sup>1</sup>	\$29,350.00 <sup>1</sup>	\$ 0.00
Construction – Bid.	\$734,300.00	\$828,722.62	\$94,422.62
<u>Phase 3 Engineering – 5%</u>	<u>\$36,350.00<sup>2</sup></u>	<u>\$41,436.13<sup>2</sup></u>	<u>\$ 5,086.13</u>
<b>Total Expense</b>	<b>\$800,000</b>	<b>\$899,508.75</b>	<b>\$99,508.75</b>

We will be working on the following streets this year:

<b>Street</b>	<b>Location</b>
<b>Resurface</b>	
Prairieview Drive	Morgan Valley Drive to Forest Avenue
Forest Avenue	Prairieview Drive to concrete pavement
Seton Creek Drive	Gloria Lane to Wollmington Drive
Wollmington Drive	Seton Creek Drive to Old Post Road

<sup>1</sup> Fixed Fee.

<sup>2</sup> Fixed percentage. Actual fee will vary based upon construction cost.

<sup>4</sup> Fixed percentage. Actual fee will vary based upon construction cost.

---

Pearces Ford	US 34 to Waubonsie Creek (south of bridge)
<b>Patching</b>	
Main Street – Southbound	At East Benton Street
Main Street – Southbound	North of Judson Avenue
Douglas Street – Southbound	South of South Madison Street
Douglas Street – Northbound	Between South Madison Street and West End Court
Judson Street	East of Main Street
Mill Road – Westbound	West of Station Drive

**RECOMMENDATION:**

Staff recommends approving the resolution authorizing supplemental expenditures of \$99,600 from the Municipal Fuel Tax Fund.

Staff recommends awarding the contract to D Construction.

**ATTACHMENTS:**

- Recommendation Letter with Bid Tab from HR Green
- Supplemental Resolution for Maintenance Under the Illinois Highway Code - BLR 14220 Oswego 2019
- Resolution 19-R-\_\_\_\_ Authorizing Contract with D Construction
- Exhibit A – 2019 Road Resurface Project Contract



▷ 420 North Front Street | Suite 100 | McHenry, IL 60050  
Main 815.385.1778 + Fax 815.385.1781

▷ [HRGREEN.COM](http://HRGREEN.COM)

June 7, 2019

Ms. Jennifer Hughes, P.E.  
Director of Public Works  
Village of Oswego  
100 Parkers Mill  
Oswego, Illinois 60543

RE: Village of Oswego - 2019 Resurfacing Program  
HR Green Job No. 190290

Dear Ms. Hughes:

The Village of Oswego received three (3) bid proposals for the 2019 Resurfacing Program at the bid opening on May 21, 2019. The three (3) bids ranged in price from a low bid of \$828,722.62 submitted by D Construction, Inc. to a high bid of \$930,888.00 submitted by Builders Paving, LLC.

We have analyzed the bid documents and checked them for accuracy and find D Construction, Inc. of Coal City, Illinois, to be the lowest qualified bidder. HR Green recommends award of the contract to D Construction, Inc. in the amount of \$828,722.62. As with all unit price contracts, the final project amount will be determined after completion of the work. The Bid Tabulation is also included herewith for your information

Please let me know if you have any questions or need any additional information.

Sincerely,

**HR GREEN, INC**

**Akram Chaudhry, PE**  
Vice President

AC/tcn

attachment

cc: Ms. Carri Parker, Village of Oswego  
Mr. Tony Simmons, HR Green, Inc.

J:\2019\190290\Corr\ltr-060719-rec2-ac.docx



**HR Green, Inc.**  
420 N. Front Street  
McHenry, IL 60050

Date: May 21, 2019

Project: Village of Oswego 2019 Resurfacing Program				Engineer: BH		<b>ENGINEER'S ESTIMATE</b>					
Job No.: 190290				Bids Rec'd: 3							
						<b>D Construction, Inc.</b> 1488 S. Broadway Coal City, IL 60416		<b>Geneva Construction Co.</b> PO Box 998 Aurora, IL 60507		<b>Builders Paving, LLC</b> 4413 Roosevelt Rd, Suite 108 Hillside, IL 60162	
NO.	DESCRIPTION	UNIT	QTY	Unit Price	Amount	Unit Price	Amount	Unit Price	Amount	Unit Price	Amount
1	BITUMINOUS MATERIALS (TACK COAT)	POUND	26,070	\$0.01	\$260.70	\$0.01	\$260.70	\$0.01	\$260.70	\$0.01	\$260.70
2	POLYMERIZED LEVELING BINDER (M.M.), IL-4.75, N50	TON	2,290	\$72.00	\$164,880.00	\$87.00	\$199,230.00	\$90.00	\$206,100.00	\$90.00	\$206,100.00
3	HOT-MIX ASPHALT SURFACE COURSE, MIX "D", N50	TON	4,580	\$65.00	\$297,700.00	\$66.00	\$302,280.00	\$72.00	\$329,760.00	\$79.00	\$361,820.00
4	HOT-MIX ASPHALT SURFACE REMOVAL, 2 3/4"	SQ YD	38,610	\$2.00	\$77,220.00	\$2.00	\$77,220.00	\$2.75	\$106,177.50	\$2.90	\$111,969.00
5	HOT-MIX ASPHALT SURFACE REMOVAL, BUTT JOINT	SQ YD	161	\$8.00	\$1,288.00	\$7.00	\$1,127.00	\$8.00	\$1,288.00	\$15.00	\$2,415.00
6	PORTLAND CEMENT CONCRETE SIDEWALK REMOVAL AND REPLACEMENT, 5 INCH	SQ FT	5,760	\$7.00	\$40,320.00	\$8.25	\$47,520.00	\$7.95	\$45,792.00	\$9.75	\$56,160.00
7	DETECTABLE WARNINGS	SQ FT	1,440	\$25.00	\$36,000.00	\$35.20	\$50,688.00	\$25.00	\$36,000.00	\$24.00	\$34,560.00
8	CLASS D PATCHES, 4 INCH	SQ YD	195	\$30.00	\$5,850.00	\$30.00	\$5,850.00	\$32.00	\$6,240.00	\$44.25	\$8,628.75
9	HOT-MIX ASPHALT SURFACE REMOVAL AND REPLACEMENT	SQ YD	1,785	\$25.00	\$44,625.00	\$35.00	\$62,475.00	\$26.00	\$46,410.00	\$40.25	\$71,846.25
10	COMBINATION CONCRETE CURB & GUTTER REMOVAL AND REPLACEMENT	FOOT	1,201	\$30.00	\$36,030.00	\$35.20	\$42,275.20	\$34.00	\$40,834.00	\$34.00	\$40,834.00
11	DRAINAGE AND UTILITY STRUCTURES TO BE ADJUSTED	EACH	40	\$375.00	\$15,000.00	\$429.00	\$17,160.00	\$350.00	\$14,000.00	\$400.00	\$16,000.00
12	SEEDING (COMPLETE)	SQ YD	921	\$10.00	\$9,210.00	\$8.00	\$7,368.00	\$12.15	\$11,190.15	\$9.00	\$8,289.00
13	THERMOPLASTIC PAVEMENT MARKING, LINE 4"	FOOT	100	\$1.50	\$150.00	\$6.96	\$696.00	\$4.13	\$413.00	\$5.25	\$525.00
14	THERMOPLASTIC PAVEMENT MARKING, LINE 6"	FOOT	150	\$2.00	\$300.00	\$10.44	\$1,566.00	\$6.20	\$930.00	\$6.50	\$975.00
15	THERMOPLASTIC PAVEMENT MARKING, LINE 12"	FOOT	144	\$4.00	\$576.00	\$20.88	\$3,006.72	\$12.40	\$1,785.60	\$9.00	\$1,296.00
16	TRAFFIC CONTROL AND PROTECTION	L SUM	1	\$5,000.00	\$5,000.00	\$10,000.00	\$10,000.00	\$13,200.00	\$13,200.00	\$9,209.30	\$9,209.30
<b>Total =</b>					\$734,409.70		\$828,722.62		\$860,380.95		\$930,888.00

^  
LOW BIDDER





Resolution for Maintenance Under the Illinois Highway Code



Resolution Number	Resolution Type	Section Number
	Supplemental	19-00000-00-GM

BE IT RESOLVED, by the President and Board of Trustees of the Village of Oswego of Oswego Illinois that there is hereby appropriated the sum of \_\_\_\_\_ Dollars ( \$99,600.00 )

Ninety-Nine Thousand, Six Hundred Dollars and 00/100----- Dollars ( \$99,600.00 )

of Motor Fuel Tax funds for the purpose of maintaining streets and highways under the applicable provisions of Illinois Highway Code from

05/01/19 to 04/30/20  
Beginning Date Ending Date

BE IT FURTHER RESOLVED, that only those operations as listed and described on the approved Estimate of Maintenance Costs, including supplemental or revised estimates approved in connection with this resolution, are eligible for maintenance with Motor Fuel Tax funds during the period as specified above.

BE IT FURTHER RESOLVED, that Village of Oswego shall submit within three months after the end of the maintenance period as stated above, to the Department of Transportation, on forms available from the Department, a certified statement showing expenditures and the balances remaining in the funds authorized for expenditure by the Department under this appropriation, and

BE IT FURTHER RESOLVED, that the Clerk is hereby directed to transmit four (4) certified originals of this resolution to the district office of the Department of Transportation.

I Tina Touchette Village Clerk in and for said Village of Oswego in the State of Illinois, and keeper of the records and files thereof, as provided by statute, do hereby certify the foregoing to be a true, perfect and complete copy of a resolution adopted by the

President and Board of Trustees of Oswego at a meeting held on 06/18/19

IN TESTIMONY WHEREOF, I have hereunto set my hand and seal this \_\_\_\_\_ day of \_\_\_\_\_ Month, Year

(SEAL)

Clerk Signature

APPROVED

Regional Engineer  
Department of Transportation

Date

**RESOLUTION NO. 19 - R - \_\_\_\_**

---

**RESOLUTION AUTHORIZING THE EXECUTION OF A CONTRACT WITH D  
CONSTRUCTION, COAL CITY, IL IN THE AMOUNT OF \$828,722.62 FOR  
MAINTENANCE OF VARIOUS STREETS**

---

**WHEREAS**, the Village of Oswego (“Village”) has a population of more than 25,000 and is therefore a “Home Rule Unit” under the 1970 Illinois Constitution; and

**WHEREAS**, the Illinois Constitution of 1970 provides that a Home Rule Unit may exercise any power and perform any function pertaining to its government and affairs, including but not limited to the power to regulate for the protection of the public health, safety, morals and welfare; to license, to tax; and to incur debt; and

**WHEREAS**, it is in the best interest of the Village of Oswego to enter into a contract with D Construction for maintenance of various streets substantially in the form attached hereto marked as “Exhibit A”.

**NOW, THEREFORE, BE IT RESOLVED BY THE PRESIDENT AND BOARD OF TRUSTEES OF THE VILLAGE OF OSWEGO, KENDALL AND WILL COUNTIES, ILLINOIS,** as follows:

**SECTION 1. INCORPORATION OF RECITAL**

That the recitals set forth above are incorporated here by reference.

**SECTION 2. SUPPORT FOR CONTRACT**

The Village President and Village Clerk are hereby authorized and directed to execute on behalf of the Village of Oswego a contract with D Construction, Coal City, IL, for maintenance of various streets substantially in the form attached as “Exhibit A.”

**SECTION 3. REPEALER**

All Resolutions or parts of Resolutions in conflict with any of the provisions of this Resolution shall be, and the same hereby repealed to the extent of any conflict.

**SECTION 4. SEVERABILITY**

This Resolution and every provision thereof shall be considered severable. If any section, paragraph, clause or provision of this Resolution is declared by a court of law to be invalid or unconstitutional, the invalidity or unconstitutionality thereof shall not affect the validity of any other provisions of this Resolution.

**SECTION 5. EFFECTIVE DATE**

This Resolution shall be in full force and effect from and after its passage.

**PASSED** by the Board of Trustees of the Village of Oswego, Kendall and Will Counties, Illinois this 18<sup>TH</sup> day of June 2019.

JAMES MARTER	_____	LUIS PEREZ	_____
TERRY OLSON	_____	JUDY SOLLINGER	_____
PAM PARR	_____	BRIAN THOMAS	_____

**APPROVED** by me, Troy Parlier, as President of the Village of Oswego, Kendall and Will Counties, Illinois this 18<sup>th</sup> day of June 2019.

\_\_\_\_\_  
TROY PARLIER, VILLAGE PRESIDENT

\_\_\_\_\_  
Tina Touchette, Village Clerk

STATE OF ILLINOIS     )  
  )  
COUNTY OF KENDALL    )        SS

**CLERK'S CERTIFICATE**  
**(RESOLUTION)**

I, Tina Touchette, the duly qualified and acting Village Clerk of the Village of Oswego, Kendall and Will Counties, Illinois, do hereby certify that I am the keeper of its books and records and that the attached hereto is a true and correct copy of a Resolution entitled:

**RESOLUTION AUTHORIZING THE EXECUTION OF A CONTRACT WITH D  
CONSTRUCTION, COAL CITY, IL IN THE AMOUNT OF \$828,722.62 FOR  
MAINTENANCE OF VARIOUS STREETS**

which Resolution was duly adopted by said Board of Trustees at a meeting held on the 18th day of June 2019, and thereafter approved by the Village President on the 18th day of June 2019.

I do further certify, in my official capacity, that a quorum of said Board of Trustees was present at said meeting and that the Board complied with all requirements of the Illinois Open Meetings Act.

IN WITNESS WHEREOF, I have hereunto set my hand this \_\_\_ day of \_\_\_\_\_ 2019.

\_\_\_\_\_  
Tina Touchette, Village Clerk  
Village of Oswego

(Seal)

19 00246

RETURN WITH BID



Local Public Agency  
Formal Contract Proposal

PROPOSAL SUBMITTED BY		
<i>D. Construction, Inc.</i>		
Contractor's Name		
<i>1488 S. Broadway</i>		
Street		P.O. Box
<i>Coal City, IL</i>	<i>60416</i>	
City	State	Zip Code

STATE OF ILLINOIS  
 COUNTY OF KENDALL  
VILLAGE OF OSWEGO  
 (Name of City, Village, Town or Road District)

FOR THE IMPROVEMENT OF  
 STREET NAME OR ROUTE NO. VARIOUS(2019 RESURFACING PGM)  
 SECTION NO. 19-00000-00-GM  
 TYPES OF FUNDS MFT

- SPECIFICATIONS (required)       PLANS (required)

**For Municipal Projects**  
 Submitted/Approved/Passed  
*[Signature]*  
 Mayor    President of Board of Trustees    Municipal Official  
 Date 5/2/19

**Department of Transportation**  
 Released for bid based on limited review  
*[Signature]*  
 Regional Engineer  
 Date 5/6/19

Note: All proposal documents, including Proposal Guaranty Checks or Proposal Bid Bonds, should be stapled together to prevent loss when bids are processed.

VILLAGE OF OSWEGO, ILLINOIS  
2019 RESURFACING PROGRAM  
SECTION NUMBER: 19-00000-00-GM

**TABLE OF CONTENTS**

**Part 1 – Legal and Procedural Documents**

Local Public Agency Formal Contract Proposal (BLR 12220)  
Local Agency Proposal Bid Bond (BLR 12230)  
Apprenticeship or Training Program Certification (BLR12325)  
Affidavit of Illinois Business Office (BLR 12326)  
Affidavit of Availability (BC 57)

**Part 2 – Contract Special Provisions**

Index for Supplemental Specifications and Recurring Special Provisions  
Check Sheet for Recurring Special Provisions  
Check Sheet for Recurring Local Roads and Streets Special Provisions

Special Provisions

Local Roads Special Provisions

BDE Special Provisions Check Sheet  
BDE Special Provisions

Kendall County Prevailing Wages, latest edition

**Part 3 – Plans**

Location Map  
General Notes  
Schedule of Quantities  
Typical Sections  
Construction Details  
IDOT Highway Standards  
IDOT District 3 Details

RETURN WITH BID

NOTICE TO BIDDERS

County KENDALL
Local Public Agency OSWEGO
Section Number 19-00000-00-GM
Route VARIOUS

Sealed proposals for the improvement described below will be received at the office of Director of Public Works,
100 Parker's Mill, Oswego, Illinois, 60543 until 10:00 AM on May 21, 2019

Sealed proposals will be opened and read publicly at the office of Director of Public Works,
100 Parker's Mill, Oswego, Illinois, 60543 at 10:00 AM on May 21, 2019

DESCRIPTION OF WORK

Name Village of Oswego 2019 Resurfacing Program Length: 12100.00 feet ( 2.29 miles)
Location Various Streets
Proposed Improvement consists of resurfacing with hot-mix asphalt surface course, polymerized leveling binder, curb and gutter removal and replacement, sidewalk removal and replacement.

- 1. Plans and proposal forms will be available in the office of Finance Dept., Oswego Village Hall, 100 Parker's Mill Oswego, IL, 60543 or online at http://www.oswegoil.org, under the Business & Development Tab-Bids & RFP
2. [X] Prequalification
3. The Awarding Authority reserves the right to waive technicalities and to reject any or all proposals as provided in BLRS Special Provision for Bidding Requirements and Conditions for Contract Proposals.
4. The following BLR Forms shall be returned by the bidder to the Awarding Authority:
5. The quantities appearing in the bid schedule are approximate and are prepared for the comparison of bids. Payment to the Contractor will be made only for the actual quantities of work performed and accepted or materials furnished according to the contract.
6. Submission of a bid shall be conclusive assurance and warranty the bidder has examined the plans and understands all requirements for the performance of work.
7. The bidder shall take no advantage of any error or omission in the proposal and advertised contract.
8. If a special envelope is supplied by the Awarding Authority, each proposal should be submitted in that envelope furnished by the Awarding Agency and the blank spaces on the envelope shall be filled in correctly to clearly indicate its contents.
9. Permission will be given to a bidder to withdraw a proposal if the bidder makes the request in writing or in person before the time for opening proposals.

RETURN WITH BID

PROPOSAL

County KENDALL  
Local Public Agency OSWEGO  
Section Number 19-00000-00-GM  
Route VARIOUS

1. Proposal of D. Construction, Inc.  
1488 S. Broadway, Coal City, IL 60416  
for the improvement of the above section by the construction of consists of resurfacing with hot-mix asphalt surface course, polymerized leveling binder, curb and gutter removal and replacement, sidewalk removal and replacement.

a total distance of 12100.00 feet, of which a distance of 12100.00 feet, ( 2.292 miles) are to be improved.

- 2. The plans for the proposed work are those prepared by HR Green, Inc., 651 Prairie Point Dr, Yorkville, IL and approved by the Department of Transportation on 5-6-19
- 3. The specifications referred to herein are those prepared by the Department of Transportation and designated as "Standard Specifications for Road and Bridge Construction" and the "Supplemental Specifications and Recurring Special Provisions" thereto, adopted and in effect on the date of invitation for bids.
- 4. The undersigned agrees to accept, as part of the contract, the applicable Special Provisions indicated on the "Check Sheet for Recurring Special Provisions" contained in this proposal.
- 5. The undersigned agrees to complete the work within \_\_\_\_\_ working days or by 08/09/2019 unless additional time is granted in accordance with the specifications.
- 6. A proposal guaranty in the proper amount, as specified in BLRS Special Provision for Bidding Requirements and Conditions for Contract Proposals, will be required. Bid Bonds will be allowed as a proposal guaranty. Accompanying this proposal is either a bid bond if allowed, on Department form BLR 12230 or a proposal guaranty check, complying with the specifications, made payable to:

Village \_\_\_\_\_ Treasurer of Oswego

The amount of the check is 5% Bid Amount Five percent bid bond (5% Bid Bond).

- 7. In the event that one proposal guaranty check is intended to cover two or more proposals, the amount must be equal to the sum of the proposal guaranties, which would be required for each individual proposal. If the proposal guaranty check is placed in another proposal, it will be found in the proposal for: Section Number N/A \_\_\_\_\_.
- 8. The successful bidder at the time of execution of the contract will be required to deposit a contract bond for the full amount of the award. When a contract bond is not required, the proposal guaranty check will be held in lieu thereof. If this proposal is accepted and the undersigned fails to execute a contract and contract bond as required, it is hereby agreed that the Bid Bond or check shall be forfeited to the Awarding Authority.
- 9. Each pay item should have a unit price and a total price. If no total price is shown or if there is a discrepancy between the product of the unit price multiplied by the quantity, the unit price shall govern. If a unit price is omitted, the total price will be divided by the quantity in order to establish a unit price.
- 10. A bid will be declared unacceptable if neither a unit price nor a total price is shown.
- 11. The undersigned submits herewith the schedule of prices on BLR 12200a covering the work to be performed under this contract.
- 12. The undersigned further agrees that if awarded the contract for the sections contained in the combinations on BLR 12200a, the work shall be in accordance with the requirements of each individual proposal for the multiple bid specified in the Schedule for Multiple Bids below.



RETURN WITH BID



SCHEDULE OF PRICES

A bid will be declared unacceptable if neither a unit price nor total price is shown,

County KENDALL  
 Local Public Agency OSWEGO  
 Section 19-00000-00-GM  
 Route VARIOUS

Schedule for Multiple Bids

Combination Letter	Sections Included in Combinations	Total
<i>N/A</i>		

Schedule for Single Bid

(For complete information covering these items, see plans and specifications)

Bidder's Proposal for making Entire Improvements *\$ 828,722.62*

Item No.	Items	Unit	Quantity	Unit Price	Total
1	BITUMINOUS MATERIALS (TACK COAT)	POUND	26,070	<i>0.01</i>	<i>260.70</i>
2	POLYMERIZED LEVELING BINDER (M.M.), IL-4.75, N50	TON	2,290	<i>87.00</i>	<i>199,230.00</i>
3	HOT-MIX ASPHALT SURFACE COURSE, MIX "D", N50	TON	4,580	<i>66.00</i>	<i>302,280.00</i>
4	HOT-MIX ASPHALT SURFACE REMOVAL, 2 3/4"	SQ YD	38,610	<i>2.00</i>	<i>77,220.00</i>
5	HOT-MIX ASPHALT SURFACE REMOVAL, BUTT JOINT	SQ YD	161	<i>7.00</i>	<i>1,127.00</i>
6	PORTLAND CEMENT CONCRETE SIDEWALK REMOVAL AND REPLACEMENT, 5 INCH	SQ FT	5,760	<i>8.25</i>	<i>47,520.00</i>
7	DETECTABLE WARNINGS	SQ FT	1,440	<i>35.20</i>	<i>50,688.00</i>
8	CLASS D PATCHES, 4 INCH	SQ YD	195	<i>30.00</i>	<i>5,850.00</i>
9	HOT-MIX ASPHALT SURFACE REMOVAL AND REPLACEMENT	SQ YD	1,785	<i>35.00</i>	<i>62,475.00</i>
10	COMBINATION CONCRETE CURB & GUTTER REMOVAL AND REPLACEMENT	FOOT	1,201	<i>35.20</i>	<i>42,275.20</i>
11	DRAINAGE AND UTILITY STRUCTURES TO BE ADJUSTED	EACH	40	<i>429.00</i>	<i>17,160.00</i>
12	SEEDING (COMPLETE)	SQ YD	921	<i>8.00</i>	<i>7,368.00</i>
13	THERMOPLASTIC PAVEMENT MARKING, LINE 4"	FOOT	100	<i>6.96</i>	<i>696.00</i>
14	THERMOPLASTIC PAVEMENT MARKING, LINE 6"	FOOT	150	<i>10.44</i>	<i>1,566.00</i>
15	THERMOPLASTIC PAVEMENT MARKING, LINE 12"	FOOT	144	<i>20.88</i>	<i>3,006.72</i>
16	TRAFFIC CONTROL AND PROTECTION	L SUM	1	<i>10,000.00</i>	<i>10,000.00</i>

RETURN WITH BID

CONTRACTOR CERTIFICATIONS

County	<u>KENDALL</u>
Local Public Agency	<u>OSWEGO</u>
Section Number	<u>19-00000-00-GM</u>
Route	<u>VARIOUS</u>

The certifications hereinafter made by the bidder are each a material representation of fact upon which reliance is placed should the Department enter into the contract with the bidder.

1. **Debt Delinquency.** The bidder or contractor or subcontractor, respectively, certifies that it is not delinquent in the payment of any tax administered by the Department of Revenue unless the individual or other entity is contesting, in accordance with the procedures established by the appropriate revenue Act, its liability for the tax or the amount of tax. Making a false statement voids the contract and allows the Department to recover all amounts paid to the individual or entity under the contract in a civil action.

2. **Bid-Rigging or Bid Rotating.** The bidder or contractor or subcontractor, respectively, certifies that it is not barred from contracting with the Department by reason of a violation of either 720 ILCS 5/33E-3 or 720 ILCS 5/33E-4.

A violation of Section 33E-3 would be represented by a conviction of the crime of bid-rigging which, in addition to Class 3 felony sentencing, provides that any person convicted of this offense or any similar offense of any state or the United States which contains the same elements as this offense shall be barred for 5 years from the date of conviction from contracting with any unit of State or local government. No corporation shall be barred from contracting with any unit of State or local government as a result of a conviction under this Section of any employee or agent of such corporation if the employee so convicted is no longer employed by the corporation and: (1) it has been finally adjudicated not guilty or (2) if it demonstrates to the governmental entity with which it seeks to contract and that entity finds that the commission of the offense was neither authorized, requested, commanded, nor performed by a director, officer or a high managerial agent in behalf of the corporation.

A violation of Section 33E-4 would be represented by a conviction of the crime of bid-rotating which, in addition to Class 2 felony sentencing, provides that any person convicted of this offense or any similar offense of any state or the United States which contains the same elements as this offense shall be permanently barred from contracting with any unit of State or local government. No corporation shall be barred from contracting with any unit of State or local government as a result of a conviction under this Section of any employee or agent of such corporation if the employee so convicted is no longer employed by the corporation and: (1) it has been finally adjudicated not guilty or (2) if it demonstrates to the governmental entity with which it seeks to contract and that entity finds that the commission of the offense was neither authorized, requested, commanded, nor performed by a director, officer or a high managerial agent in behalf of the corporation.

3. **Bribery.** The bidder or contractor or subcontractor, respectively, certifies that it has not been convicted of bribery or attempting to bribe an officer or employee of the State of Illinois or any unit of local government, nor has the firm made an admission of guilt of such conduct which is a matter of record, nor has an official, agent, or employee of the firm committed bribery or attempted bribery on behalf of the firm and pursuant to the direction or authorization of a responsible official of the firm.

4. **Interim Suspension or Suspension.** The bidder or contractor or subcontractor, respectively, certifies that it is not currently under a suspension as defined in Subpart I of Title 44 Subtitle A Chapter III Part 6 of the Illinois Administrative Code. Furthermore, if suspended prior to completion of this work, the contract or contracts executed for the completion of this work may be cancelled.

RETURN WITH BID

SIGNATURES

County KENDALL  
Local Public Agency OSWEGO  
Section Number 19-00000-00-GM  
Route VARIOUS

(If an individual)

Signature of Bidder \_\_\_\_\_

Business Address \_\_\_\_\_  
\_\_\_\_\_

(If a partnership)

Firm Name \_\_\_\_\_

Signed By \_\_\_\_\_

Business Address \_\_\_\_\_  
\_\_\_\_\_

Inset Names and Addressed of All Partners



\_\_\_\_\_  
\_\_\_\_\_  
\_\_\_\_\_  
\_\_\_\_\_

(If a corporation)

Corporate Name D. Construction, Inc.

Signed By [Signature]  
President

Business Address 1488 S. Broadway  
Coal City, FL 32046

Inset Names of Officers



President Benneth Sanderio

Secretary Tamara L. Hansen

Treasurer Tamara L. Hansen

Attest:

[Signature]  
Secretary



Illinois Department of Transportation

Local Agency Proposal Bid Bond 2019 Resurfacing Program

Route VARIOUS
County KENDALL
Local Agency OSWEGO
Section 19-00000-00-GM

RETURN WITH BID

PAPER BID BOND

WE D. Construction, Inc., 1488 South Broadway, Coal City, IL 60416 as PRINCIPAL, and Liberty Mutual Insurance Company as SURETY.

are held jointly, severally and firmly bound unto the above Local Agency (hereafter referred to as "LA") in the penal sum of 5% of the total bid price, or for the amount specified in the proposal documents in effect on the date of invitation for bids whichever is the lesser sum.

WHEREAS THE CONDITION OF THE FOREGOING OBLIGATION IS SUCH that, the said PRINCIPAL is submitting a written proposal to the LA acting through its awarding authority for the construction of the work designated as the above section.

THEREFORE If the proposal is accepted and a contract awarded to the PRINCIPAL by the LA for the above designated section and the PRINCIPAL shall within fifteen (15) days after award enter into a formal contract, furnish surety guaranteeing the faithful performance of the work, and furnish evidence of the required insurance coverage, all as provided in the "Standard Specifications for Road and Bridge Construction" and applicable Supplemental Specifications, then this obligation shall become void; otherwise it shall remain in full force and effect.

IN THE EVENT the LA determines the PRINCIPAL has failed to enter into a formal contract in compliance with any requirements set forth in the preceding paragraph, then the LA acting through its awarding authority shall immediately be entitled to recover the full penal sum set out above, together with all court costs, all attorney fees, and any other expense of recovery.

IN TESTIMONY WHEREOF, the said PRINCIPAL and the said SURETY have caused this instrument to be signed by their respective officers this 21st day of May, 2019

D. Construction, Inc.

Principal

By: Kenneth Sandeno (Signature and Title) President

By: (Signature and Title)

(If PRINCIPLE is a joint venture of two or more contractors, the company names, and authorized signatures of each contractor must be affixed.)

Liberty Mutual Insurance Company

Surety

(Name of Surety)

By: James I. Moore (Signature of Attorney-in-Fact)

STATE OF ILLINOIS, COUNTY OF DuPage I. Sherry Bacskai, a Notary Public in and for said county, do hereby certify that Kenneth Sandeno & James I. Moore

(Insert names of individuals signing on behalf of PRINCIPAL & SURETY)

who are each personally known to me to be the same persons whose names are subscribed to the foregoing instrument on behalf of PRINCIPAL and SURETY, appeared before me this day in person and acknowledged respectively, that they signed and delivered said instruments as their free and voluntary act for the uses and purposes therein set forth.

Given under my hand and notarial seal this 21st day of May 2019

My commission expires 10/22/2019

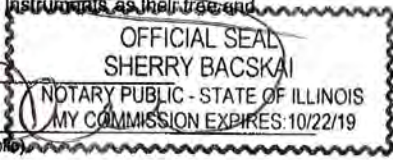

ELECTRONIC BID BOND

Electronic bid bond is allowed (box must be checked by LA if electronic bid bond is allowed) The Principal may submit an electronic bid bond, in lieu of completing the above section of the Proposal Bid Bond Form. By providing an electronic bid bond ID code and signing below, the Principal is ensuring the identified electronic bid bond has been executed and the Principal and Surety are firmly bound unto the LA under the conditions of the bid bond as shown above.

Electronic Bid Bond ID Code (grid)

(Company/Bidder Name) (Signature and Title) Date

This Power of Attorney limits the acts of those named herein, and they have no authority to bind the Company except in the manner and to the extent herein stated. Not valid for mortgage, note, loan, letter of credit, bank deposit, currency rate, interest rate or residual value guarantees. To confirm the validity of this Power of Attorney call 610-832-8240 between 9:00 am and 4:30 pm EST on any business day.



**Liberty Mutual.**

**SURETY**

Liberty Mutual Insurance Company  
The Ohio Casualty Insurance Company  
West American Insurance Company

**POWER OF ATTORNEY**

KNOWN ALL PERSONS BY THESE PRESENTS: That The Ohio Casualty Insurance Company is a corporation duly organized under the laws of the State of New Hampshire, that Liberty Mutual Insurance Company is a corporation duly organized under the laws of the State of Massachusetts, and West American Insurance Company is a corporation duly organized under the laws of the State of Indiana (herein collectively called the "Companies"), pursuant to and by authority herein set forth, does hereby name, constitute and appoint, James I. Moore of the city of Downers Grove, state of IL its true and lawful attorney-in-fact, with full power and authority hereby conferred to sign, execute and acknowledge the following surety bond:

Principal Name: D. Construction, Inc.

Obligee Name: Village of Oswego

Surety Bond Number: Bid Bond Bond Amount: See Bond Form

IN WITNESS WHEREOF, this Power of Attorney has been subscribed by an authorized officer or official of the Companies and the corporate seals of the Companies have been affixed thereto this 12<sup>th</sup> day of December, 2018.



The Ohio Casualty Insurance Company  
Liberty Mutual Insurance Company  
West American Insurance Company

By: David M. Carey  
David M. Carey, Assistant Secretary

STATE OF PENNSYLVANIA      SS  
COUNTY OF MONTGOMERY

On this 12<sup>th</sup> day of December, 2018, before me personally appeared David M. Carey, who acknowledged himself to be the Assistant Secretary of Liberty Mutual Insurance Company, The Ohio Casualty Company, and West American Insurance Company, and that he, as such, being authorized so to do, execute the foregoing instrument for the purposes therein contained by signing on behalf of the corporations by himself as a duly authorized officer.

IN WITNESS WHEREOF, I have hereunto subscribed my name and affixed my notarial seal at King of Prussia, Pennsylvania, on the day and year first above written.



COMMONWEALTH OF PENNSYLVANIA  
Notarial Seal  
Teresa Pastella, Notary Public  
Upper Merion Twp., Montgomery County  
My Commission Expires March 28, 2021  
Member, Pennsylvania Association of Notaries

By: Teresa Pastella  
Teresa Pastella, Notary Public

This Power of Attorney is made and executed pursuant to and by authority of the following By-laws and Authorizations of Liberty Mutual Insurance Company, The Ohio Casualty Insurance Company, and West American Insurance Company which resolutions are now in full force and effect reading as follows:

**ARTICLE IV – OFFICERS** – Section 12. Power of Attorney. Any officer or other official of the Corporation authorized for that purpose in writing by the Chairman or the President, and subject to such limitation as the Chairman or the President may prescribe, shall appoint such attorneys-in-fact, as may be necessary to act in behalf of the Corporation to make, execute, seal, acknowledge and deliver as surety any and all undertakings, bonds, recognizances and other surety obligations. Such attorneys-in-fact, subject to the limitations set forth in their respective powers of attorney, shall have full power to bind the Corporation by their signature and execution of any such instruments and to attach thereto the seal of the Corporation. When so executed, such instruments shall be as binding as if signed by the President and attested to by the Secretary. Any power or authority granted to any representative or attorney-in-fact under the provisions of this article may be revoked at any time by the Board, the Chairman, the President or by the officer or officers granting such power or authority.

**ARTICLE XIII – Execution of Contracts – SECTION 5. Surety Bonds and Undertakings.** Any officer of the Company authorized for that purpose in writing by the chairman or the president, and subject to such limitations as the chairman or the president may prescribe, shall appoint such attorneys-in-fact, as may be necessary to act in behalf of the Company to make, execute, seal, acknowledge and deliver as surety any and all undertakings, bonds, recognizances and other surety obligations. Such attorneys-in-fact subject to the limitations set forth in their respective powers of attorney, shall have full power to bind the Company by their signature and execution of any such instruments and to attach thereto the seal of the Company. When so executed such instruments shall be as binding as if signed by the president and attested by the secretary.

**Certificate of Designation** – The President of the Company, acting pursuant to the Bylaws of the Company, authorizes David M. Carey, Assistant Secretary to appoint such attorneys-in-fact as may be necessary to act on behalf of the Company to make, execute, seal, acknowledge and deliver as surety any and all undertakings, bonds, recognizances and other surety obligations.

**Authorization** – By unanimous consent of the Company's Board of Directors, the Company consents that facsimile or mechanically reproduced signature of any assistant secretary of the Company, wherever appearing upon a certified copy of any power of attorney issued by the Company in connection with surety bonds, shall be valid and binding upon the Company with the same force and effect as though manually affixed.

I, Renee C. Llewellyn, the undersigned, Assistant Secretary, of Liberty Mutual Insurance Company, The Ohio Casualty Insurance Company, and West American Insurance Company do hereby certify that this power of attorney executed by said Companies is in full force and effect and has not been revoked.

IN TESTIMONY WHEREOF, I have hereunto set my hand and affixed the seals of said Companies this 21st day of May, 2019.



By: Renee C. Llewellyn  
Renee C. Llewellyn, Assistant Secretary



Apprenticeship or Training Program Certification

Return with Bid

Route VARIOUS
County KENDALL
Local Agency OSWEGO
Section 19-00000-00-GM

All contractors are required to complete the following certification:

- For this contract proposal or for all groups in this deliver and install proposal.
For the following deliver and install groups in this material proposal:

Blank lines for listing deliver and install groups.

Illinois Department of Transportation policy, adopted in accordance with the provisions of the Illinois Highway Code, requires this contract to be awarded to the lowest responsive and responsible bidder. The award decision is subject to approval by the Department. In addition to all other responsibility factors, this contract or deliver and install proposal requires all bidders and all bidders' subcontractors to disclose participation in apprenticeship or training programs that are (1) approved by and registered with the United States Department of Labor's Bureau of Apprenticeship and Training, and (2) applicable to the work of the above indicated proposals or groups. Therefore, all bidders are required to complete the following certification:

- I. Except as provided in paragraph IV below, the undersigned bidder certifies that it is a participant, either as an individual or as part of a group program, in an approved apprenticeship or training program applicable to each type of work or craft that the bidder will perform with its own employees.
II. The undersigned bidder further certifies for work to be performed by subcontract that each of its subcontractors submitted for approval either (A) is, at the time of such bid, participating in an approved, applicable apprenticeship or training program; or (B) will, prior to commencement of performance of work pursuant to this contract, establish participation in an approved apprenticeship or training program applicable to the work of the subcontract.
III. The undersigned bidder, by inclusion in the list in the space below, certifies the official name of each program sponsor holding the Certificate of Registration for all of the types of work or crafts in which the bidder is a participant and that will be performed with the bidder's employees. Types of work or craft that will be subcontracted shall be included and listed as subcontract work. The list shall also indicate any type of work or craft job category for which there is no applicable apprenticeship or training program available.

Carpenter Local 363, Cement Masons Local 638, Ironworkers Local 383,
Laborers Local 582, Operatives Local 150

- IV. Except for any work identified above, any bidder or subcontractor that shall perform all or part of the work of the contract or deliver and install proposal solely by individual owners, partners or members and not by employees to whom the payment of prevailing rates of wages would be required, check the following box, and identify the owner/operator workforce and positions of ownership.

N/A  
\_\_\_\_\_  
\_\_\_\_\_  
\_\_\_\_\_

The requirements of this certification and disclosure are a material part of the contract, and the contractor shall require this certification provision to be included in all approved subcontracts. The bidder is responsible for making a complete report and shall make certain that each type of work or craft job category that will be utilized on the project is accounted for and listed. The Department at any time before or after award may require the production of a copy of each applicable Certificate of Registration issued by the United States Department of Labor evidencing such participation by the contractor and any or all of its subcontractors. In order to fulfill the participation requirement, it shall not be necessary that any applicable program sponsor be currently taking or that it will take applications for apprenticeship, training or employment during the performance of the work of this contract or deliver and install proposal.

Bidder: D. Construction Inc.

Address: 1488 S. Broadway  
Coal City, IL 60416

By: [Signature]  
(Signature)

Title: President Beneth Sunders

RETURN WITH BID



Affidavit of Illinois Business Office

County KENDALL  
Local Public Agency OSWEGO  
Section Number 19-00000-00-GM  
Route VARIOUS

State of Illinois )  
 ) ss.  
County of Grundy )

I, Kenneth Sanders of Morris, Illinois,  
(Name of Affiant) (City of Affiant) (State of Affiant)

being first duly sworn upon oath, states as follows:

1. That I am the President of D. Construction, Inc.  
officer or position bidder
2. That I have personal knowledge of the facts herein stated.
3. That, if selected under this proposal, D. Construction, Inc., will maintain a  
(bidder) business office in the State of Illinois which will be located in Grundy County, Illinois.
4. That this business office will serve as the primary place of employment for any persons employed in the construction contemplated by this proposal.
5. That this Affidavit is given as a requirement of state law as provided in Section 30-22(8) of the Illinois Procurement Code.

[Signature]  
(Signature)  
Kenneth Sanders  
(Print Name of Affiant)

This instrument was acknowledged before me on 21 day of May, 2019.

(SEAL)



[Signature]  
(Signature of Notary Public)





# Illinois Department of Transportation

Bureau of Construction  
2300 South Dirksen Parkway/Room 322  
Springfield, Illinois 62764

## Affidavit of Availability For the Letting of \_\_\_\_\_

Instructions: Complete this form by either typing or using black ink. "Authorization to Bid" will not be issued unless both sides of this form are completed in detail. Use additional forms as needed to list all work.

### Part I. Work Under Contract

*See the attached letter and certificate of eligibility*

List below all work you have under contract as either a prime contractor or a subcontractor. It is required to include all pending low bids not yet awarded or rejected. In a joint venture, list only that portion of the work which is the responsibility of your company. The uncompleted dollar value is to be based upon the most recent engineer's or owners estimate, and must include work subcontracted to others. If no work is contracted, show **NONE**.

	1	2	3	4	Awards Pending	
Contract Number						
Contract With						
Estimated Completion Date						
Total Contract Price						Accumulated Totals
Uncompleted Dollar Value if Firm is the Prime Contractor						
Uncompleted Dollar Value if Firm is the Subcontractor						
Total Value of All Work						

### Part II. Awards Pending and Uncompleted Work to be done with your own forces.

List below the uncompleted dollar value of work for each contract and awards pending to be completed with your own forces. All work subcontracted to others will be listed on the reverse of this form. In a joint venture, list only that portion of the work to be done by your company. If no work is contracted, show **NONE**.

	1	2	3	4	Awards Pending	Accumulated Totals
Earthwork						
Portland Cement Concrete Paving						
HMA Plant Mix						
HMA Paving						
Clean & Seal Cracks/Joints						
Aggregate Bases & Surfaces						
Highway, R.R. and Waterway Structures						
Drainage						
Electrical						
Cover and Seal Coats						
Concrete Construction						
Landscaping						
Fencing						
Guardrail						
Painting						
Signing						
Cold Milling, Planning & Rotomilling						
Demolition						
Pavement Markings (Paint)						
Other Construction (List)						
						\$ 0.00
Totals						

Disclosure of this information is **REQUIRED** to accomplish the statutory purpose as outlined in the "Illinois Procurement Code." Failure to comply will result in non-issuance of an "Authorization To Bid." This form has been approved by the State Forms Management Center.

**Part III. Work Subcontracted to Others.**

For each contract described in Part I, list all the work you have subcontracted to others.

	1	2	3	4	Awards Pending
Subcontractor					
Type of Work					
Subcontract Price					
Amount Uncompleted					
Subcontractor					
Type of Work					
Subcontract Price					
Amount Uncompleted					
Subcontractor					
Type of Work					
Subcontract Price					
Amount Uncompleted					
Subcontractor					
Type of Work					
Subcontract Price					
Amount Uncompleted					
Subcontractor					
Type of Work					
Subcontract Price					
Amount Uncompleted					
Total Uncompleted					

I, being duly sworn, do hereby declare that this affidavit is a true and correct statement relating to ALL uncompleted contracts of the undersigned for Federal, State, County, City and private work, including ALL subcontract work, ALL pending low bids not yet awarded or rejected and ALL estimated completion dates.

Subscribed and sworn to before me  
 this \_\_\_\_\_ day of \_\_\_\_\_, \_\_\_\_\_ Type or Print Name \_\_\_\_\_  
 Officer or Director \_\_\_\_\_ Title \_\_\_\_\_

\_\_\_\_\_  
 Notary Public

My commission expires \_\_\_\_\_

(Notary Seal)

Signed \_\_\_\_\_

Company \_\_\_\_\_

Address \_\_\_\_\_



## **“D” Construction, Inc.**

---

General Contractor

1488 South Broadway, Coal City, IL 60416  
Office (815) 634-2555 FAX (815) 634-8748

May 21, 2019

Village of Oswego  
Attn. Director of Public Works  
100 Parker's Mill  
Oswego, *IL. 60543*

**Sealed Bid For:** “Village of Oswego 2019 Resurfacing Program – Section No. 19-00000-00-GM”

**Bid Due:** 05/21/19 at 10:00 am

To whom it may concern:

Per the Illinois Department of Transportation Rules of Prequalification of Contractors please find our request to forgo filing an Affidavit of Availability per Article 650.310 sub D based on our Super Unlimited financial rating (See Attached Certificate of Eligibility).

If you have any questions, please call (815) 634-2555.

Sincerely,



Kenneth Sandeno  
President



**Illinois Department  
of Transportation**

# Certificate of Eligibility

D Construction, Inc.  
1488 South Broadway Street Coal City, IL 60416

Contractor No 1320

WHO HAS FILED WITH THE DEPARTMENT AN APPLICATION FOR PREQUALIFICATION STATEMENT OF EXPERIENCE, EQUIPMENT AND FINANCIAL CONDITION IS HEREBY QUALIFIED TO BID AT ANY OF DEPARTMENT OF TRANSPORTATION LETTINGS IN THE CLASSES OF WORK AND WITHIN THE AMOUNT AND OTHER LIMITATIONS OF EACH CLASSIFICATION, AS LISTED BELOW, FOR SUCH PERIOD AS THE UNCOMPLETED WORK FROM ALL SOURCES DOES NOT EXCEED SUPER UNLIMITED

001	EARTHWORK	\$35,875,000
002	PCC PAVING	\$32,475,000
003	HMA PLANT MIX	Unlimited
006	CLEAN & SEAL CRACKS/JOINTS	\$1,000,000
012	DRAINAGE	\$24,875,000
014	ELECTRICAL	\$8,325,000
017	CONCRETE CONSTRUCTION	\$30,900,000
018	LANDSCAPING	\$1,825,000
024	GROUTING	\$1,075,000
032	COLD MILL, PLAN. & ROTOMILL	\$4,525,000
034	DEMOLITION	\$3,400,000
08A	AGGREGATE BASES & SURF. (A)	\$25,200,000
09C	HWY., R.R. & WATERWAY STR.	\$42,800,000

THIS CERTIFICATE OF ELIGIBILITY IS VALID FROM 1/2/2019 TO 2/29/2020 INCLUSIVE, AND SUPERSEDES ANY CERTIFICATE PREVIOUSLY ISSUED, BUT IS SUBJECT TO REVISION OR REVOCATION, IF AND WHEN CHANGES IN THE FINANCIAL CONDITION OF THE CONTRACTING FIRM OR OTHER FACTS JUSTIFY SUCH REVISIONS OR REVOCATION. ISSUED AT SPRINGFIELD, ILLINOIS ON 1/3/2019.

*Jim Kell*

Engineer of Construction

INDEX  
FOR  
SUPPLEMENTAL SPECIFICATIONS  
AND RECURRING SPECIAL PROVISIONS

Adopted January 1, 2019

This index contains a listing of SUPPLEMENTAL SPECIFICATIONS, frequently used RECURRING SPECIAL PROVISIONS, and LOCAL ROADS AND STREETS RECURRING SPECIAL PROVISIONS.

ERRATA Standard Specifications for Road and Bridge Construction  
(Adopted 4-1-16) (Revised 1-1-19)

SUPPLEMENTAL SPECIFICATIONS

<u>Std. Spec. Sec.</u>	<u>Page No.</u>
106 Control of Materials .....	1
107 Legal Regulations and Responsibility to Public .....	2
403 Bituminous Surface Treatment (Class A-1, A-2, A-3) .....	3
404 Micro-Surfacing and Slurry Sealing .....	4
405 Cape Seal .....	15
406 Hot-Mix Asphalt Binder and Surface Course .....	25
420 Portland Cement Concrete Pavement .....	26
424 Portland Cement Concrete Sidewalk .....	28
442 Pavement Patching .....	29
502 Excavation for Structures .....	30
503 Concrete Structures .....	32
504 Precast Concrete Structures .....	35
542 Pipe Culverts .....	36
586 Sand Backfill for Vaulted Abutments .....	37
602 Catch Basin, Manhole, Inlet, Drainage Structure, and Valve Vault Construction, Adjustment, and Reconstruction .....	39
630 Steel Plate Beam Guardrail .....	40
631 Traffic Barrier Terminals .....	43
670 Engineer's Field Office and Laboratory .....	44
701 Work Zone Traffic Control and Protection .....	45
704 Temporary Concrete Barrier .....	46
780 Pavement Striping .....	48
781 Raised Reflective Pavement Markers .....	49
888 Pedestrian Push-Button .....	50
1001 Cement .....	51
1003 Fine Aggregates .....	52
1004 Coarse Aggregates .....	53
1006 Metals .....	56
1020 Portland Cement Concrete .....	58
1043 Adjusting Rings .....	60
1050 Poured Joint Sealers .....	62
1069 Pole and Tower .....	64
1077 Post and Foundation .....	65
1096 Pavement Markers .....	66
1101 General Equipment .....	67

1102	Hot-Mix Asphalt Equipment .....	68
1103	Portland Cement Concrete Equipment .....	70
1105	Pavement Marking Equipment .....	72
1106	Work Zone Traffic Control Devices .....	74



The Following Recurring Special Provisions Indicated By An "X" Are Applicable To This Contract And Are Included By Reference:

Recurring Special Provisions

<u>Check Sheet #</u>		<u>Page No.</u>
1	<input type="checkbox"/> Additional State Requirements for Federal-Aid Construction Contracts	75
2	<input type="checkbox"/> Subletting of Contracts (Federal-Aid Contracts)	78
3	<input type="checkbox"/> EEO	79
4	<input type="checkbox"/> Specific EEO Responsibilities Non Federal-Aid Contracts	89
5	<input type="checkbox"/> Required Provisions - State Contracts	94
6	<input type="checkbox"/> Asbestos Bearing Pad Removal	100
7	<input type="checkbox"/> Asbestos Waterproofing Membrane and Asbestos HMA Surface Removal	101
8	<input type="checkbox"/> Temporary Stream Crossings and In-Stream Work Pads	102
9	<input type="checkbox"/> Construction Layout Stakes Except for Bridges	103
10	<input type="checkbox"/> Construction Layout Stakes	106
11	<input type="checkbox"/> Use of Geotextile Fabric for Railroad Crossing	109
12	<input type="checkbox"/> Subsealing of Concrete Pavements	111
13	<input type="checkbox"/> Hot-Mix Asphalt Surface Correction	115
14	<input type="checkbox"/> Pavement and Shoulder Resurfacing	117
15	<input type="checkbox"/> Patching with Hot-Mix Asphalt Overlay Removal	118
16	<input type="checkbox"/> Polymer Concrete	120
17	<input type="checkbox"/> PVC Pipeliner	122
18	<input type="checkbox"/> Bicycle Racks	123
19	<input type="checkbox"/> Temporary Portable Bridge Traffic Signals	125
20	<input type="checkbox"/> Work Zone Public Information Signs	127
21	<input type="checkbox"/> Nighttime Inspection of Roadway Lighting	128
22	<input type="checkbox"/> English Substitution of Metric Bolts	129
23	<input type="checkbox"/> Calcium Chloride Accelerator for Portland Cement Concrete	130
24	<input type="checkbox"/> Quality Control of Concrete Mixtures at the Plant	131
25	<input checked="" type="checkbox"/> Quality Control/Quality Assurance of Concrete Mixtures	139
26	<input type="checkbox"/> Digital Terrain Modeling for Earthwork Calculations	155
27	<input type="checkbox"/> Reserved	157
28	<input type="checkbox"/> Preventive Maintenance - Bituminous Surface Treatment	158
29	<input type="checkbox"/> Reserved	164
30	<input type="checkbox"/> Reserved	165
31	<input type="checkbox"/> Reserved	166
32	<input type="checkbox"/> Temporary Raised Pavement Markers	167
33	<input type="checkbox"/> Restoring Bridge Approach Pavements Using High-Density Foam	168
34	<input type="checkbox"/> Portland Cement Concrete Inlay or Overlay	171
35	<input type="checkbox"/> Portland Cement Concrete Partial Depth Hot-Mix Asphalt Patching	175

The Following Local Roads And Streets Recurring Special Provisions Indicated By An "X" Are Applicable To This Contract And Are Included By Reference:

Local Roads And Streets Recurring Special Provisions

<u>Check Sheet #</u>		<u>Page No.</u>
LRS 1	<b>Reserved</b>	179
LRS 2	<input type="checkbox"/> Furnished Excavation	180
LRS 3	<input checked="" type="checkbox"/> Work Zone Traffic Control Surveillance	181
LRS 4	<input checked="" type="checkbox"/> Flaggers in Work Zones	182
LRS 5	<input checked="" type="checkbox"/> Contract Claims	183
LRS 6	<input checked="" type="checkbox"/> Bidding Requirements and Conditions for Contract Proposals	184
LRS 7	<input type="checkbox"/> Bidding Requirements and Conditions for Material Proposals	190
LRS 8	<b>Reserved</b>	196
LRS 9	<input type="checkbox"/> Bituminous Surface Treatments	197
LRS 10	<b>Reserved</b>	198
LRS 11	<input checked="" type="checkbox"/> Employment Practices	199
LRS 12	<input checked="" type="checkbox"/> Wages of Employees on Public Works	201
LRS 13	<input checked="" type="checkbox"/> Selection of Labor	203
LRS 14	<input type="checkbox"/> Paving Brick and Concrete Paver Pavements and Sidewalks	204
LRS 15	<input checked="" type="checkbox"/> Partial Payments	207
LRS 16	<input type="checkbox"/> Protests on Local Lettings	208
LRS 17	<input checked="" type="checkbox"/> Substance Abuse Prevention Program	209
LRS 18	<input type="checkbox"/> Multigrade Cold Mix Asphalt	210





Local Public Agency	County	Section Number
Village of Oswego	Kendall	19-00000-00-GM

The following Special Provision supplement the "Standard Specifications for Road and Bridge Construction", adopted

**April 1, 2016**, the latest edition of the "Manual on Uniform Traffic Control Devices for Streets and Highways", and the "Manual of Test Procedures of Materials" in effect on the date of invitation of bids, and the Supplemental Specification and Recurring Special Provisions indicated on the Check Sheet included here in which apply to and govern the construction of the above named section, and in case of conflict with any parts, or parts of said Specifications, the said Special Provisions shall take precedence and shall govern.

**DESCRIPTION OF WORK**

Work to be performed under this contract consists of roadway improvements within the Village of Oswego. This work shall include, but not be limited to, hot-mix asphalt surface removal, hot-mix asphalt surface course, leveling binder, combination concrete curb and gutter removal and replacement, sidewalk removal and replacement, and all incidental and collateral work necessary to complete the project as described herein.

**LOCATION OF WORK**

This project consists of the resurfacing of various roads and streets in the Village of Oswego as shown on the location maps and in the project summary. The total length of the improvement is 12,100 feet.

**MAINTENANCE OF ROADWAYS**

Beginning on the date that work begins on this project, the Contractor shall assume responsibility for normal maintenance of all existing roadways within the limits of the improvement. This normal maintenance shall include all repair work deemed necessary by the Engineer, but shall not include snow removal operations. Traffic control and protection for maintenance of roadways will be provided by the Contractor as required by the Engineer.

If items of work have not been provided in the contract, or otherwise specified for payment, such items, including the accompanying traffic control and protection required by the Engineer, will be paid for in accordance with Article 109.04 of the Standard Specifications.

**COMPLETION DATE**

This contract shall be completed by August 9, 2019; if the Contractor fails to complete the work by the above-specified date, liquidated damages will be charged in accordance with Article 108.09 of the Standard Specifications and shall be strictly adhered to.

**REDUCTION IN THE SCOPE OF WORK**

The "Project Summary" is a listing of work to be completed. However, due to budgetary constraints the awarding authority reserves the right to substantially reduce the scope of work to be completed under the contract in accordance with Article 104.02 of the Standard Specifications. No allowance will be made for delay or anticipated profits as the result of a decrease in the quantities of work to be performed or reduction in asphalt thickness up to a half inch (1/2").

**MOBILIZATION**

This Contract contains no provisions for Mobilization. Therefore, Section 671 of the Standard Specifications is deleted.

Village of Oswego

Kendall

19-00000-00-GM

**DRIVEWAY CLOSING**

It will be the Contractor's responsibility to notify residents, businesses and the Village when access to the parking and driveways will be temporarily closed due to construction operations. At locations where the curb in front of a driveway is scheduled to be removed, the Contractor shall contact the homeowner or business 24 hours prior to removing the curb or drive approach. The Contractor shall distribute notices provided by the Village, to businesses and residents. Every effort shall be made to accommodate access to these properties. The Contractor shall not be allowed to close a Driveway for more than 48 hours under any circumstance. The Contractor shall be responsible for maintaining the barricades to prevent traffic from using the driveways during this period. The business owners affected by the resurfacing shall be notified 48 hours in advance of the closing of the parking areas in front of their businesses.

**RESIDENT NOTIFICATION**

It will be the Contractor's responsibility to notify residents and the Village at least 24 hours prior to start of work on their streets; also notifying the Residents when access to their driveways will be temporarily closed due to curb and gutter, gutter, and/or driveway replacement. The Contractor shall distribute notices provided by the Village, to residents. Every effort shall be made to accommodate access to these properties. The contractor shall not be allowed to close a Driveway for more than 48 hours under any circumstance.

**TRAFFIC CONTROL AND PROTECTION**

All roads shall be kept open to traffic. The Contractor shall provide access to local traffic at all times. The Contractor should take particular note of the applicable portions of Article 107.14 of the Standard Specifications. All signs, except those referring to daily lane closures, shall be post mounted in accordance with Standard 701901 for all projects that exceed four-day duration. Construction signs referring to daytime lane closures during working hours shall be removed, covered or turned away from the view of the motorists during nonworking hours.

The Contractor shall furnish, erect, maintain and remove all signs, barricades, flaggers and other traffic control devices as may be necessary for the purpose of regulating, warning or guiding traffic. Placement and maintenance of all traffic control devices shall be in accordance with the applicable parts of Section 701 of the Standard Specifications, the Illinois Manual on Uniform Traffic Control Devices for Streets and Highways and the Highway Standard contained herein.

Special attention is called to Article 107.09 and Section 701 of the Standard Specifications and the following Highways Standards, Supplemental Specifications, Details, Quality Standard for Work Zone Traffic Control Devices, Recurring Special Provisions, and Special Provisions contained herein relating to traffic control. It should be noted that Type I or Type II barricades will be required adjacent to the pavement in areas where a drop off of 3" or more occurs in accordance with Article 701.07.

**Standards**

701501, 701801, 701901

**Special Provisions**

Maintenance of Roadways

Construction and Maintenance Signs (LR 702)

Flaggers in Work Zones (LRS#4)

The Contractor shall contact the Village, at least 72 hours in advance of beginning work. Construction operations shall be conducted in a manner such that streets will be open to traffic at all times, and access to 106 abutting property shall be maintained.

Village of Oswego

Kendall

19-00000-00-GM

The Contractor shall be responsible for providing a proposed scheduling, phasing and traffic control plan. The Village will review these plans and provide the contractor with any necessary modifications in writing. The Contractor will then be responsible for incorporating these changes into the proposed scheduling, phasing and traffic control plan.

At the preconstruction meeting, the Contractor shall furnish the name and telephone number where he may be reached during non-working hours of the individual in his direct employ that is to be responsible for the installation and maintenance of the traffic control of this project. If the actual installation and maintenance are to be accomplished by a subcontractor, consent shall be requested of the Engineer at the time of the preconstruction meeting in accordance with Article 108.01 of the Standard Specifications. This shall not relieve the Contractor of the requirements to have a responsible individual in his direct employ supervise this work.

This work will be paid for at the contract LUMP SUM price for TRAFFIC CONTROL AND PROTECTION.

#### HOT-MIX ASPHALT SURFACE REMOVAL, BUTT JOINT

When HOT-MIX ASPHALT SURFACE REMOVAL are to be constructed under traffic, the Contractor shall provide and maintain temporary asphalt ramps at both upstream and downstream ends of the pavement area removed. The temporary ramps shall be constructed immediately upon completion of the removal operation by leveling and filling with bituminous material, as necessary. Ramps shall have a minimum taper rate of 3' per inch of thickness and shall be removed prior to placing the proposed surface course. Temporary ramps will not be paid for separately but shall be considered incidental to the bid price per square yard for HOT-MIX ASPHALT SURFACE REMOVAL item being performed.

HOT-MIX ASPHALT SURFACE REMOVAL, BUTT JOINT consists of constructing butt joints for a satisfactory transition between pavement being resurfaced and pavement remaining at existing grade, and shall be accomplished in accordance with the applicable portions of Article 406.08 and Section 440 of the Standard Specifications and the detail included herein. Should any pavement be damaged by removal operations sufficient to warrant replacement, in the Engineer's judgment, the Contractor shall replace it in kind for no additional payment.

The grindings generated shall become the property of the contractor and disposed of outside the limits of the project.

HOT-MIX ASPHALT SURFACE REMOVAL shall be measured in place and the area computed in square yards. This work will be paid for at the contract unit price per SQUARE YARD for HOT-MIX ASPHALT SURFACE REMOVAL, BUTT JOINT. Saw cutting shall be considered incidental.

The Contractor will be required to resurface milled surfaces within 7 calendar days, failure to do so shall result in a charge of \$1,000 per each calendar day over the above specified time.

#### HOT-MIX ASPHALT DRIVEWAY

This work shall consist of the removal of existing asphalt driveway aprons and the construction of hot-mix asphalt driveway pavement on a prepared sub-grade in accordance with applicable articles of Section 406, 440 and 482 of the Standard Specifications, Special Provisions for Hot-Mix Asphalt.

This work shall be done at locations of proposed gutter, as shown on the project summary, and at locations where the Engineer determines it will be necessary to provide a smooth transition in the driveway pavement. Additional compensation will NOT be allowed for varying materials types or thicknesses

Village of Oswego

Kendall

19-00000-00-GM

comprising of the existing driveway approach.

The Contractor shall form a perpendicular straight joint by full depth machine sawing at the end of the portion to be removed to prevent surface spalling. These areas must be marked and measured for payment by the Engineer prior to removal. The Contractor at his/her expense shall repair any driveway pavement damaged by the Contractor during the driveway pavement removal operations.

The Contractor shall fill the holes created by the removal of the driveway pavement with aggregate base course (CA-6 crushed) so that the residents can use their driveways until the start of installation of the improvements. The cost of the aggregate base course will be included in the cost of the item of work being constructed.

Materials for the hot-mix asphalt driveway pavement shall consist of the following:

- Three inches (3") of hot-mix asphalt surface course

The hot-mix asphalt driveway surface shall produce a tight surface conforming to the grade of the adjacent area. The hot-mix asphalt surface to remain shall be saw-cut in a neat, straight line.

Prior to replacement with the hot-mix asphalt surface course, the exposed base course shall be shaped, compacted, and primed including the exposed edge of the hot-mix asphalt surface remaining to the satisfaction of the Engineer. Additional crushed aggregate (CA-6 gradation) base course may be required in the preparation of the base course as indicated above. Any additional aggregate base course required for the preparation of the base and filling of depressions created by the construction shall be considered included to this pay item.

This work will be paid for at the contract unit price per SQUARE YARD for HOT-MIX ASPHALT DRIVEWAY, of the thickness specified, which price shall include saw cutting and the removal and disposal of the existing driveway pavement.

#### HOT-MIX ASPHALT SURFACE REMOVAL AND REPLACEMENT

Revise Article 442.01 to read:

"This work shall consist of removal of the existing pavement, the necessary excavation and replacement with a Hot-Mix Asphalt Binder and Surface Course material as detailed in the plans, and in accordance with applicable articles of Section 442 of the Standard Specifications except that the four area types, namely types 1, 2, 3 and 4 are combined under this pay item.

Exact quantities and locations of patching will be determined by the Engineer."

#### Measurement and Basis of Payment.

This work will be paid for at the contract unit price per square yard for HOT-MIX ASPHALT SURFACE REMOVAL AND REPLACEMENT, which price shall include full depth saw cutting, pavement removal, necessary excavation, furnishing, placing and compacting the Hot-Mix Asphalt patching mixture to the depth indicated, and the removal and disposal of any surplus material.

#### AGGREGATE BASE COURSE REMOVAL & REPLACEMENT, 12 INCH

This work shall consist of the removal of the existing aggregate base course to a minimum depth of 12 inches (12"), disposal of surplus material, compacting the subgrade and installation of Aggregate Base Course Type B to a minimum compacted thickness of 12 inches (12").

Village of Oswego

Kendall

19-00000-00-GM

After the subgrade has been brought to a smooth grade and proper shape, it shall be compacted by use of vibratory rollers and/or compactors.

Replacement shall consist of installing CA-6 crushed aggregate. This work shall be done in accordance with the applicable articles of Section 351 of the Standard Specifications. This item shall also be used for subgrade removal and replacement.

This work will be paid for at the contract unit price per SQUARE YARD for AGGREGATE BASE COURSE REMOVAL AND REPLACEMENT, 12 INCH, which price shall include all equipment, labor and materials required to complete this work.

#### COMBINATION CONCRETE CURB AND GUTTER REMOVAL AND REPLACEMENT

This work shall consist of the removal and replacement of existing concrete curb and gutter at locations as determined by the Engineer. The purpose of this work is to replace curb and gutter that is damaged and/or requires replacement to improve the street drainage. The replacement curb and gutter section shall be as directed by the Engineer and match that of the existing. This work shall be done in accordance with Section 440 and Section 606 of the Standard Specifications and the concrete shall meet the requirements of Article 1020.04 for SI concrete.

The Contractor shall perform his work in a manner causing minimal inconvenience to the residents and motoring public. The trenches created by the removal operations in front of the Driveways shall be filled with Aggregate to provide access to the residents to their driveways, except for curb and gutter replacement when the driveways will be closed to the residents for 48 hours. The Contractor shall use High Early Strength Concrete in order to limit driveway closure to 48 hours.

The minimum gutter flag depth of the new curb and gutter will be ten inches (10") regardless of the size and type of the existing curb and gutter.

Reinforcing bars may be embedded in old concrete curb. Sawing, removal, and disposal of reinforcing bars will not be paid for separately but shall be included in the cost of the item removed.

Removal of the existing curb and gutter shall be performed with a full-depth perpendicular saw cut, done in such a manner as to prevent damage to the curb and gutter to remain in place. Any saw cut edges broken off or otherwise damaged, or any curb sections to remain in place that are raised up or pushed down by the removal operation shall be removed and replaced to the satisfaction of the Engineer with no additional compensation to be made to the Contractor. The Contractor shall note that the Engineer will measure the curb and gutter as marked for replacement prior to removal of the existing curb. This measurement, as marked, will be the final payment quantity and shall be verified by the Contractor prior to removal.

Where new curb and gutter meets existing curb and gutter to remain, the gutters shall be connected with two 5/8" diameter reinforcing bars, twelve inches (12") long. Holes 5/8" in diameter shall be drilled six inches (6") into the existing concrete curb and gutter prior to driving reinforcing bars into place.

Contraction joints shall be provided at uniform intervals not to exceed twelve feet (12'). Construction joints with dowel bars shall be provided at the end of a day's pour. Expansion joints shall be constructed at intervals not to exceed sixty feet (60') or as determined by the Engineer and shall consist of a minimum of one inch (1") thick preformed expansion joint filler conforming to the cross-section of the curb and gutter and shall be provided with two (2) No. 5 (#5) by eighteen inch (18") coated smooth dowel bars conforming to Article 1006.11(b) of the Standard Specifications. The dowel bars shall be fitted with a cap having a pinched stop that will provide a minimum of one inch (1") of expansion.

Village of Oswego

Kendall

19-00000-00-GM

Removal of the existing pavement will be required in order to install a full front face form. Steel angle pieces will not be allowed for forming. The area between the edge of the existing pavement and the face of the new gutter shall be cleaned of all loose material and shall be filled with Class PV/ SI concrete to a minimum of six inch (6") width, which will be included in the cost of COMBINATION CONCRETE CURB AND GUTTER REMOVAL AND REPLACEMENT.

All new curb and gutter shall be depressed at sidewalk ramp locations. The transition from full-height curb and gutter to depressed curb shall occur over a distance of three feet (3') minimum.

This work shall be paid for at the contract unit price per FOOT for COMBINATION CONCRETE CURB AND GUTTER REMOVAL AND REPLACEMENT which price shall include all of the above including 4" of Aggregate Base Course Type B (CA-7 Crushed) under the new curb where unsuitable materials are found, and as directed by the Engineer.

#### PORTLAND CEMENT CONCRETE SIDEWALK REMOVAL AND REPLACEMENT, 5 INCH

This work shall be done in accordance with Section 424 and 440 of the Standard Specifications and the concrete shall meet the requirements of Class SI concrete. The Contractor shall remove the existing sidewalk and sufficient sub-grade to allow for placement of two inches (2") of approved CA-6 crushed stone or crushed gravel on a compacted sub-grade. Replacement shall include the installation of Portland Cement Concrete sidewalk to a minimum thickness of five inches (5"), and thickened to six inches (6") across driveways, and two inches (2") of CA-6 sub-base under the new sidewalk where unsuitable materials are found, and as directed by the Engineer. If filling is required in the sidewalk subgrade, it shall consist of placing and compacting an approved granular material to the satisfaction of the Engineer as incidental.

The Contractor shall use High Early Strength concrete for sidewalk replacement at the location of the driveways at no additional cost to the contract. The Contractor shall fill the voids created by the removal of sidewalk at the location of the driveways with crushed aggregate so that the residents can use their driveways until the start of sidewalk replacement operations.

At sidewalk ramp locations side curbs or flares may be required to meet ADA requirements. When a flare or curb is constructed it shall meet the three foot (3') minimum curb transition.

This work will be paid for at the contract unit price per SQUARE FOOT for PORTLAND CEMENT CONCRETE SIDEWALK REMOVAL AND REPLACEMENT, 5 INCH, which price shall include any necessary excavation for the installation of two inches (2") of approved CA-6 crushed stone or crushed gravel under the new sidewalk, filling with compacted granular material, and additional thickness at driveways. At the Contractor's option CA-16 crushed aggregate may be substituted for CA-6.

No stamps advertising the Contractor, construction companies, or other private concerns shall be placed in the concrete.

#### DETECTABLE WARNINGS

This work shall consist of the installation of pre-fabricated replaceable panel of truncated domes twenty-four inches (24") wide and forty-eight inches (48") in length on concrete sidewalk accessibility ramps at locations as directed by the Engineer.

Truncated domes shall be in accordance with Article 424.09 of the Standard Specifications. The domes

Village of Oswego

Kendall

19-00000-00-GM

shall parallel the pavement crosswalk in accordance with the latest Highway Standard. The panel shall be Red. The panel shall meet the requirements of ASTM C1028 – Slip Resistance and ASTM G155 – Accelerated Weathering.

The Detectable Warning Panel shall be one of the following products, or an approved equal:

ADA Solutions, Inc. Cast-in-Place available from  
Stetsons Building Products, Inc.  
2425 20th Street  
Rockford, IL 61104  
Phone: (800) 383-2181

OR

EZ-Set Tile available from  
Traffic Control Corporation  
10435 Argonne Woods Drive  
Woodridge, IL 60517  
Phone: (800) 996-6511

OR

Armor-Tile Replaceable Cast-In Place System available from  
White Cap Construction Supply  
8124 W. 188th Street  
Mokena, IL 60448  
Phone: (815) 464-8828

This work will be paid for at the contract unit price per SQUARE FOOT for DETECTABLE WARNINGS.

#### SEEDING (COMPLETE)

This work shall be performed on the parkway areas at locations of curb and sidewalk removal and replacement and proposed gutter as shown in the project summary and as directed by the Engineer.

This work shall consist of furnishing, placing and shaping an average depth of 2 inches (2") of pulverized topsoil, Seeding Class 1A, Erosion Control Blanket (Article 251.04), Supplemental Watering and Fertilizer Nutrients at the rate of 270 pounds per acre, from the edge of proposed curb and/or sidewalk to taper into the existing parkway as shown on the plans and in the project summary.

This work shall be done in accordance with the applicable articles of Section 211, Section 250, Section 251 and Section 480 of the Standard Specifications.

In some areas; the thickness of topsoil may exceed 2 inches (2") to bring the proposed grade flush with the edge of pavement. The Contractor shall coordinate with the Engineer on restoration of the disturbed areas. Blending of the disturbed areas with the adjacent terrain based on this coordination is considered part of this contract and shall be paid at the contract unit price for the necessary items, which prices shall include all labor, material and equipment necessary to perform the work. The cost for the additional topsoil shall be included in SEEDING (COMPLETE) pay item.

SEEDING (COMPLETE) will be measured in place and the area computed in square yards. This work will

Village of Oswego

Kendall

19-00000-00-GM

be paid for at the contract unit price per SQUARE YARD for SEEDING (COMPLETE), which price shall include all labor, material and equipment necessary to complete the work as specified above

Payment for this item shall not be made until the seed has germinated, and a growth of 2" grass strand has been established.

#### DRAINAGE AND UTILITY STRUCTURES TO BE ADJUSTED

All Inlets, Catch Basins, Manholes, Valve Vaults, and Sanitary Structures shall be classified as DRAINAGE AND UTILITY STRUCTURES, and the work shall be performed as per Section 602 and 603 of the Standard Specifications.

This work will be paid for at the contract unit price EACH for DRAINAGE AND UTILITY STRUCTURES TO BE ADJUSTED. The use of steel rings for adjustment will not be allowed.

#### HOT-MIX ASPHALT BINDER, LEVELING BINDER AND SURFACE COURSE

Effective: May 2013

Revised: May 2016

Description and Materials. The Hot Mix Asphalt mix design, production, and construction (materials, machinery, and methods) shall conform to the specific requirements of the standard specifications for Road and Bridge Construction adopted by the Illinois Department of Transportation, applicable Special Provisions, and Chapter 44 of the Bureau of Local Roads and Streets Manual and the following:

1. All asphalt mix designs shall target 3.5% Air Voids and all production shall trend about 3.5% Air Voids.
2. N50, IL-9.5 mm Surface and Level courses shall have a minimum of 40% passing the #8 sieve.
3. Use of FRAP or RAS shall be in accordance with IDOT prevailing Specifications and Special Provision.
4. Re-proportioning (within SSRBC adjustments allowed) of IDOT verified mix designs may be allowed and the contractor must submit these values for a review by the Engineer at least one week prior to the first day of production.
5. One field TSR test by the Contractor will be required to validate changes.
6. The AJMF during production shall meet the remaining IDOT volumetric requirements.

#### HOT-MIX ASPHALT MIXTURE REQUIREMENTS

##### ITEM AC TYPE

Overlay AC TYPE

Full Depth HMA VOIDS

Hot Mix Asphalt Surface Course,

Mix "D," N50 PG 58-22/58-28\* PG 58-28/58-34\* 3.5% @ 50 GYR

Leveling Binder

(Machine Method), N50 PG 58-22/58-28\* PG 58-28-/58-34\* 3.5% @ 50 GYR

Hot Mix Asphalt Binder Course,

IL-19, N50 PG 58-22/58-28\* PG 58-28/58-34\* 3.5% @ 50 GYR

Note: The unit weight used to calculate all HMA surface mixture quantities is 112 lbs. /sq. yd. /in

\*When Asphalt Binder Replacement (ABR) exceeds 15%.

Construction:



Village of Oswego

Kendall

19-00000-00-GM

7. Tack coat all longitudinal joints (hot and cold) and curb faces.
8. In lieu of a pneumatic tired roller, the Contractor may use a vibratory roller set with low amplitude or multiple passes with the tandem roller as approved by the Engineer.
9. Auger extensions are required on all lifts, all mixes.
10. Reverse augers must be installed properly.
11. Augers shall be installed properly at the bearing point.
12. Roll (compact) the confined and curb line longitudinal joint by overlapping by 6" from the hot to cold side of mat and / or curbing.
13. Paving of the full roadway width shall be completed at the end of each day. Longitudinal joints shall be closed daily and within one truck load of HMA to prevent cold joints. Any violation shall require saw cutting edge back 3" to expose straight edge, shall be tack coated twice, and will be straight and uniform.
14. Asphalt along the curb line shall be compacted such that the asphalt is 1/4" above the curb line.

State of Illinois  
Department of Transportation  
Bureau of Local Roads and Streets

SPECIAL PROVISION  
FOR  
INSURANCE

Effective: February 1, 2007  
Revised: August 1, 2007

All references to Sections or Articles in this specification shall be construed to mean specific Section or Article of the Standard Specifications for Road and Bridge Construction, adopted by the Department of Transportation.

The Contractor shall name the following entities as additional insured under the Contractor's general liability insurance policy in accordance with Article 107.27:

---

---

---

---

---

---

---

---

The entities listed above and their officers, employees, and agents shall be indemnified and held harmless in accordance with Article 107.26.

State of Illinois  
Department of Transportation  
Bureau of Local Roads and Streets  
SPECIAL PROVISION  
FOR  
CONSTRUCTION AND MAINTENANCE SIGNS

Effective: January 1, 2004  
Revised: June 1, 2007

All references to Sections or Articles in this specification shall be construed to mean a specific Section or Article of the Standard Specifications for Road and Bridge Construction, adopted by the Department of Transportation.

701.14. Signs. Add the following paragraph to Article 701.14:

All warning signs shall have minimum dimensions of 1200 mm x 1200 mm (48" x 48") and have a black legend on a fluorescent orange reflectorized background, meeting, as a minimum, Type AP reflectivity requirements of Table 1091-2 in Article 1091.02.

BDE SPECIAL PROVISIONS  
For the April 26, 2019 and June 14, 2019 Lettings

The following special provisions indicated by a "check mark" are applicable to this contract and will be included by the Project Coordination and Implementation Section of the BD&E. An \* indicates a new or revised special provision for the letting.

File Name	#		Special Provision Title	Effective	Revised
80099	1	<input type="checkbox"/>	Accessible Pedestrian Signals (APS)	April 1, 2003	Jan. 1, 2014
80274	2	<input type="checkbox"/>	Aggregate Subgrade Improvement	April 1, 2012	April 1, 2016
80192	3	<input type="checkbox"/>	Automated Flagger Assistance Device	Jan. 1, 2008	
80173	4	<input type="checkbox"/>	Bituminous Materials Cost Adjustments	Nov. 2, 2006	Aug. 1, 2017
80241	5	<input type="checkbox"/>	Bridge Demolition Debris	July 1, 2009	
50261	6	<input type="checkbox"/>	Building Removal-Case I (Non-Friable and Friable Asbestos)	Sept. 1, 1990	April 1, 2010
50481	7	<input type="checkbox"/>	Building Removal-Case II (Non-Friable Asbestos)	Sept. 1, 1990	April 1, 2010
50491	8	<input type="checkbox"/>	Building Removal-Case III (Friable Asbestos)	Sept. 1, 1990	April 1, 2010
50531	9	<input type="checkbox"/>	Building Removal-Case IV (No Asbestos)	Sept. 1, 1990	April 1, 2010
80404	10	<input type="checkbox"/>	Coarse Aggregate Quality for Micro-Surfacing and Cape Seals	Jan. 1, 2019	
*	80384	<input type="checkbox"/>	Compensable Delay Costs	June 2, 2017	April 1, 2019
80198	12	<input type="checkbox"/>	Completion Date (via calendar days)	April 1, 2008	
80199	13	<input type="checkbox"/>	Completion Date (via calendar days) Plus Working Days	April 1, 2008	
80293	14	<input type="checkbox"/>	Concrete Box Culverts with Skews > 30 Degrees and Design Fills ≤ 5 Feet	April 1, 2012	July 1, 2016
80311	15	<input type="checkbox"/>	Concrete End Sections for Pipe Culverts	Jan. 1, 2013	April 1, 2016
80277	16	<input type="checkbox"/>	Concrete Mix Design – Department Provided	Jan. 1, 2012	April 1, 2016
80261	17	<input type="checkbox"/>	Construction Air Quality – Diesel Retrofit	June 1, 2010	Nov. 1, 2014
80387	18	<input type="checkbox"/>	Contrast Preformed Plastic Pavement Marking	Nov. 1, 2017	
*	80029	<input type="checkbox"/>	Disadvantaged Business Enterprise Participation	Sept. 1, 2000	March 2, 2019
80402	20	<input type="checkbox"/>	Disposal Fees	Nov. 1, 2018	
80378	21	<input type="checkbox"/>	Dowel Bar Inserter	Jan. 1, 2017	Jan. 1, 2018
80405	22	<input type="checkbox"/>	Elastomeric Bearings	Jan. 1, 2019	
80388	23	<input type="checkbox"/>	Equipment Parking and Storage	Nov. 1, 2017	
80229	24	<input type="checkbox"/>	Fuel Cost Adjustment	April 1, 2009	Aug. 1, 2017
80304	25	<input type="checkbox"/>	Grooving for Recessed Pavement Markings	Nov. 1, 2012	Nov. 1, 2017
80246	26	<input type="checkbox"/>	Hot-Mix Asphalt – Density Testing of Longitudinal Joints	Jan. 1, 2010	Aug. 1, 2018
80398	27	<input type="checkbox"/>	Hot-Mix Asphalt – Longitudinal Joint Sealant	Aug. 1, 2018	Jan. 1, 2019
80406	28	<input type="checkbox"/>	Hot-Mix Asphalt – Mixture Design Verification and Production (Modified for I-FIT Projects)	Jan. 1, 2019	
80399	29	<input type="checkbox"/>	Hot-Mix Asphalt – Oscillatory Roller	Aug. 1, 2018	Nov. 1, 2018
80347	30	<input type="checkbox"/>	Hot-Mix Asphalt – Pay for Performance Using Percent Within Limits – Jobsite Sampling	Nov. 1, 2014	Aug. 1, 2018
80383	31	<input type="checkbox"/>	Hot-Mix Asphalt – Quality Control for Performance	April 1, 2017	Jan. 1, 2019
80376	32	<input type="checkbox"/>	Hot-Mix Asphalt – Tack Coat	Nov. 1, 2016	
80392	33	<input type="checkbox"/>	Lights on Barricades	Jan. 1, 2018	
80336	34	<input type="checkbox"/>	Longitudinal Joint and Crack Patching	April 1, 2014	April 1, 2016
*	80411	<input type="checkbox"/>	Luminaires, LED	April 1, 2019	
*	80393	<input type="checkbox"/>	Manholes, Valve Vaults, and Flat Slab Tops	Jan. 1, 2018	March 1, 2019
80400	37	<input type="checkbox"/>	Mast Arm Assembly and Pole	Aug. 1, 2018	
80045	38	<input type="checkbox"/>	Material Transfer Device	June 15, 1999	Aug. 1, 2014
80394	39	<input type="checkbox"/>	Metal Flared End Section for Pipe Culverts	Jan. 1, 2018	April 1, 2018
80165	40	<input type="checkbox"/>	Moisture Cured Urethane Paint System	Nov. 1, 2006	Jan. 1, 2010
80349	41	<input type="checkbox"/>	Pavement Marking Blackout Tape	Nov. 1, 2014	April 1, 2016
80371	42	<input type="checkbox"/>	Pavement Marking Removal	July 1, 2016	
80390	43	<input type="checkbox"/>	Payments to Subcontractors	Nov. 2, 2017	
80389	44	<input type="checkbox"/>	Portland Cement Concrete	Nov. 1, 2017	
80359	45	<input type="checkbox"/>	Portland Cement Concrete Bridge Deck Curing	April 1, 2015	Nov. 1, 2017

80300	46	<input type="checkbox"/>	Preformed Plastic Pavement Marking Type D - Inlaid	April 1, 2012	April 1, 2016
80328	47	<input type="checkbox"/>	Progress Payments	Nov. 2, 2013	
34261	48	<input type="checkbox"/>	Railroad Protective Liability Insurance	Dec. 1, 1986	Jan. 1, 2006
80157	49	<input type="checkbox"/>	Railroad Protective Liability Insurance (5 and 10)	Jan. 1, 2006	
80306	50	<input type="checkbox"/>	Reclaimed Asphalt Pavement (RAP) and Reclaimed Asphalt Shingles (RAS)	Nov. 1, 2012	Jan. 1, 2019
80407	51	<input type="checkbox"/>	Removal and Disposal of Regulated Substances	Jan. 1, 2019	
80395	52	<input type="checkbox"/>	Sloped Metal End Section for Pipe Culverts	Jan. 1, 2018	
80340	53	<input type="checkbox"/>	Speed Display Trailer	April 2, 2014	Jan. 1, 2017
80127	54	<input type="checkbox"/>	Steel Cost Adjustment	April 2, 2004	Aug. 1, 2017
80408	55	<input type="checkbox"/>	Steel Plate Beam Guardrail Manufacturing	Jan. 1, 2019	
80397	56	<input type="checkbox"/>	Subcontractor and DBE Payment Reporting	April 2, 2018	
* 80391	57	<input type="checkbox"/>	Subcontractor Mobilization Payments	Nov. 2, 2017	April 1, 2019
80317	58	<input type="checkbox"/>	Surface Testing of Hot-Mix Asphalt Overlays	Jan. 1, 2013	April 1, 2016
80298	59	<input type="checkbox"/>	Temporary Pavement Marking	April 1, 2012	April 1, 2017
20338	60	<input type="checkbox"/>	Training Special Provisions	Oct. 15, 1975	
80403	61	<input type="checkbox"/>	Traffic Barrier Terminal, Type 1 Special	Nov. 1, 2018	
80409	62	<input type="checkbox"/>	Traffic Control Devices - Cones	Jan. 1, 2019	
80410	63	<input type="checkbox"/>	Traffic Spotters	Jan. 1, 2019	
80318	64	<input type="checkbox"/>	Traversable Pipe Grate for Concrete End Sections	Jan. 1, 2013	Jan. 1, 2018
80288	65	<input type="checkbox"/>	Warm Mix Asphalt	Jan. 1, 2012	April 1, 2016
80302	66	<input type="checkbox"/>	Weekly DBE Trucking Reports	June 2, 2012	April 2, 2015
80071	67	<input type="checkbox"/>	Working Days	Jan. 1, 2002	

The following special provisions are in the 2019 Supplemental Specifications and Recurring Special Provisions.

<u>File Name</u>	<u>Special Provision Title</u>	<u>New Location(s)</u>	<u>Effective</u>	<u>Revised</u>
80382	Adjusting Frames and Grates	Articles 602.02(s) and (t), 1043.04, and 1043.05	April 1, 2017	
80366	Butt Joints	Article 406.08(c)	July 1, 2016	
80386	Calcium Aluminate Cement for Class PP-5 Concrete Patching	Article 1001.01(e)	Nov. 1, 2017	
80396	Class A and B Patching	Articles 442.06(a)(1) and (2)	Jan. 1, 2018	Nov. 1, 2018
80377	Portable Changeable Message Signs	Articles 701.20(h) and 1106.02(i)	Nov. 1, 2016	April 1, 2017
80385	Portland Cement Concrete Sidewalk	Article 424.12	Aug. 1, 2017	

The following special provision has been deleted from use.

<u>File Name</u>	<u>Special Provision Title</u>	<u>Effective</u>	<u>Revised</u>
80401	Portland Cement Concrete Pavement Connector for Bridge Approach Slab	Aug. 1, 2018	

The following special provisions require additional information from the designer. The additional information needs to be submitted as a separate document. The Project Coordination and Implementation section will then include the information in the applicable special provision.

- Bridge Demolition Debris
- Building Removal - Case I
- Building Removal - Case II
- Building Removal - Case III
- Building Removal-Case IV
- Completion Date
- Completion Date Plus Working Days
- DBE Participation
- Material Transfer Device
- Railroad Protective Liability Insurance
- Training Special Provisions
- Working Days

## CONSTRUCTION AIR QUALITY – DIESEL RETROFIT (BDE)

Effective: June 1, 2010

Revised: November 1, 2014

The reduction of emissions of particulate matter (PM) for off-road equipment shall be accomplished by installing retrofit emission control devices. The term “equipment” refers to diesel fuel powered devices rated at 50 hp and above, to be used on the jobsite in excess of seven calendar days over the course of the construction period on the jobsite (including rental equipment).

Contractor and subcontractor diesel powered off-road equipment assigned to the contract shall be retrofitted using the phased in approach shown below. Equipment that is of a model year older than the year given for that equipment’s respective horsepower range shall be retrofitted:

Effective Dates	Horsepower Range	Model Year
June 1, 2010 <sup>1/</sup>	600-749	2002
	750 and up	2006
June 1, 2011 <sup>2/</sup>	100-299	2003
	300-599	2001
	600-749	2002
	750 and up	2006
June 1, 2012 <sup>2/</sup>	50-99	2004
	100-299	2003
	300-599	2001
	600-749	2002
	750 and up	2006

1/ Effective dates apply to Contractor diesel powered off-road equipment assigned to the contract.

2/ Effective dates apply to Contractor and subcontractor diesel powered off-road equipment assigned to the contract.

The retrofit emission control devices shall achieve a minimum PM emission reduction of 50 percent and shall be:

- a) Included on the U.S. Environmental Protection Agency (USEPA) *Verified Retrofit Technology List* (<http://www.epa.gov/cleandiesel/verification/verif-list.htm>), or verified by the California Air Resources Board (CARB) (<http://www.arb.ca.gov/diesel/verdev/vt/cvt.htm>); or
- b) Retrofitted with a non-verified diesel retrofit emission control device if verified retrofit emission control devices are not available for equipment proposed to be used on the project, and if the Contractor has obtained a performance certification from the retrofit

device manufacturer that the emission control device provides a minimum PM emission reduction of 50 percent.

Note: Large cranes (Crawler mounted cranes) which are responsible for critical lift operations are exempt from installing retrofit emission control devices if such devices adversely affect equipment operation.

Diesel powered off-road equipment with engine ratings of 50 hp and above, which are unable to be retrofitted with verified emission control devices or if performance certifications are not available which will achieve a minimum 50 percent PM reduction, may be granted a waiver by the Department if documentation is provided showing good faith efforts were made by the Contractor to retrofit the equipment.

Construction shall not proceed until the Contractor submits a certified list of the diesel powered off-road equipment that will be used, and as necessary, retrofitted with emission control devices. The list(s) shall include (1) the equipment number, type, make, Contractor/rental company name; and (2) the emission control devices make, model, USEPA or CARB verification number, or performance certification from the retrofit device manufacturer. Equipment reported as fitted with emissions control devices shall be made available to the Engineer for visual inspection of the device installation, prior to being used on the jobsite.

The Contractor shall submit an updated list of retrofitted off-road construction equipment as retrofitted equipment changes or comes on to the jobsite. The addition or deletion of any diesel powered equipment shall be included on the updated list.

If any diesel powered off-road equipment is found to be in non-compliance with any portion of this special provision, the Engineer will issue the Contractor a diesel retrofit deficiency deduction.

Any costs associated with retrofitting any diesel powered off-road equipment with emission control devices shall be considered as included in the contract unit prices bid for the various items of work involved and no additional compensation will be allowed. The Contractor's compliance with this notice and any associated regulations shall not be grounds for a claim.

### **Diesel Retrofit Deficiency Deduction**

When the Engineer determines that a diesel retrofit deficiency exists, a daily monetary deduction will be imposed for each calendar day or fraction thereof the deficiency continues to exist. The calendar day(s) will begin when the time period for correction is exceeded and end with the Engineer's written acceptance of the correction. The daily monetary deduction will be \$1,000.00 for each deficiency identified.

The deficiency will be based on lack of diesel retrofit emissions control.

If a Contractor accumulates three diesel retrofit deficiency deductions for the same piece of equipment in a contract period, the Contractor will be shutdown until the deficiency is corrected.

Such a shutdown will not be grounds for any extension of the contract time, waiver of penalties, or be grounds for any claim.

80261



## **EQUIPMENT PARKING AND STORAGE (BDE)**

Effective: November 1, 2017

Replace the first paragraph of Article 701.11 of the Standard Specifications with the following.

**“701.11 Equipment Parking and Storage.** During working hours, all vehicles and/or nonoperating equipment which are parked, two hours or less, shall be parked at least 8 ft (2.5 m) from the open traffic lane. For other periods of time during working and for all nonworking hours, all vehicles, materials, and equipment shall be parked or stored as follows.

- (a) When the project has adequate right-of-way, vehicles, materials, and equipment shall be located a minimum of 30 ft (9 m) from the pavement.
- (b) When adequate right-of-way does not exist, vehicles, materials, and equipment shall be located a minimum of 15 ft (4.5 m) from the edge of any pavement open to traffic.
- (c) Behind temporary concrete barrier, vehicles, materials, and equipment shall be located a minimum of 24 in. (600 mm) behind free standing barrier or a minimum of 6 in. (150 mm) behind barrier that is either pinned or restrained according to Article 704.04. The 24 in. or 6 in. measurement shall be from the base of the non-traffic side of the barrier.
- (d) Behind other man-made or natural barriers meeting the approval of the Engineer.”

80388

## HOT-MIX ASPHALT - DENSITY TESTING OF LONGITUDINAL JOINTS (BDE)

Effective: January 1, 2010

Revised: August 1, 2018

Description. This work shall consist of testing the density of longitudinal joints as part of the quality control/quality assurance (QC/QA) of hot-mix asphalt (HMA). Work shall be according to Section 1030 of the Standard Specifications except as follows.

Quality Control/Quality Assurance (QC/QA). Delete the second and third sentence of the third paragraph of Article 1030.05(d)(3) of the Standard Specifications.

Add the following paragraphs to the end of Article 1030.05(d)(3) of the Standard Specifications:

“Longitudinal joint density testing shall be performed at each random density test location. Longitudinal joint testing shall be located at a distance equal to the lift thickness or a minimum of 4 in. (100 mm), from each pavement edge. (i.e. for a 5 in. (125 mm) lift the near edge of the density gauge or core barrel shall be within 5 in. (125 mm) from the edge of pavement.) Longitudinal joint density testing shall be performed using either a correlated nuclear gauge or cores.

- a. Confined Edge. Each confined edge density shall be represented by a one-minute nuclear density reading or a core density and shall be included in the average of density readings or core densities taken across the mat which represents the Individual Test.
- b. Unconfined Edge. Each unconfined edge joint density shall be represented by an average of three one-minute density readings or a single core density at the given density test location and shall meet the density requirements specified herein. The three one-minute readings shall be spaced 10 ft (3 m) apart longitudinally along the unconfined pavement edge and centered at the random density test location.

When a longitudinal joint sealant (LJS) is applied, longitudinal joint density testing will not be required on the joint(s) sealed.”

Revise the Density Control Limits table in Article 1030.05(d)(4) of the Standard Specifications to read:

“Mixture Composition	Parameter	Individual Test (includes confined edges)	Unconfined Edge Joint Density Minimum
IL-4.75	Ndesign = 50	93.0 – 97.4% <sup>1/</sup>	91.0%
IL-9.5	Ndesign = 90	92.0 – 96.0%	90.0%
IL-9.5,IL-9.5L	Ndesign < 90	92.5 – 97.4%	90.0%
IL-19.0	Ndesign = 90	93.0 – 96.0%	90.0%
IL-19.0, IL-19.0L	Ndesign < 90	93.0 <sup>2/</sup> – 97.4%	90.0%

SMA	Ndesign = 50 & 80	93.5 – 97.4%	91.0%”
-----	-------------------	--------------	--------

80246

**HOT-MIX ASPHALT – OSCILLATORY ROLLER (BDE)**

Effective: August 1, 2018  
 Revised: November 1, 2018

Add the following to Article 406.03 of the Standard Specifications:

“(j) Oscillatory Roller .....1101.01”

Revise Table 1 and Note 3/ of Table 1 in Article 406.07(a) of the Standard Specifications to read:

“TABLE 1 - MINIMUM ROLLER REQUIREMENTS FOR HMA				
	Breakdown Roller (one of the following)	Intermediate Roller	Final Roller (one or more of the following)	Density Requirement
Level Binder: (When the density requirements of Article 406.05(c) do not apply.)	P <sup>3/</sup>	--	V <sub>S</sub> , P <sup>3/</sup> , T <sub>B</sub> , T <sub>F</sub> , 3W, O <sub>T</sub>	To the satisfaction of the Engineer.
Binder and Surface <sup>1/</sup>  Level Binder <sup>1/</sup> : (When the density requirements of Article 406.05(c) apply.)	V <sub>D</sub> , P <sup>3/</sup> , T <sub>B</sub> , 3W, O <sub>T</sub> , O <sub>B</sub>	P <sup>3/</sup> , O <sub>T</sub> , O <sub>B</sub>	V <sub>S</sub> , T <sub>B</sub> , T <sub>F</sub> , O <sub>T</sub>	As specified in Articles: 1030.05(d)(3), (d)(4), and (d)(7).
IL-4.75 and SMA <sup>4/ 5/</sup>	T <sub>B</sub> , 3W, O <sub>T</sub>	--	T <sub>F</sub> , 3W, O <sub>T</sub>	
Bridge Decks <sup>2/</sup>	T <sub>B</sub>	--	T <sub>F</sub>	As specified in Articles 582.05 and 582.06.

3/ A vibratory roller (V<sub>D</sub>) or oscillatory roller (O<sub>T</sub> or O<sub>B</sub>) may be used in lieu of the pneumatic-tired roller on mixtures containing polymer modified asphalt binder.”

Add the following to EQUIPMENT DEFINITION in Article 406.07(a) contained in the Errata of the Supplemental Specifications:

“O<sub>T</sub> - Oscillatory roller, tangential impact mode. Maximum speed is 3.0 mph (4.8 km/h) or 264 ft/min (80 m/min).

O<sub>B</sub> - Oscillatory roller, tangential and vertical impact mode, operated at a speed to produce not less than 10 vertical impacts/ft (30 impacts/m).”

Add the following to Article 1101.01 of the Standard Specifications:

“(h) Oscillatory Roller. The oscillatory roller shall be self-propelled and provide a smooth operation when starting, stopping, or reversing directions. The oscillatory roller shall be able to operate in a mode that will provide tangential impact force with or without vertical impact force by using at least one drum. The oscillatory roller shall be equipped with water tanks and sprinkling devices, or other approved methods, which shall be used to wet the drums to prevent material pickup. The drum(s) amplitude and frequency of the tangential and vertical impact force shall be approximately the same in each direction and meet the following requirements:

- (1) The minimum diameter of the drum(s) shall be 42 in. (1070 mm)48 in. (1200 mm);
- (2) The minimum length of the drum(s) shall be 57 in. (1480 mm)66 in. (1650 mm);
- (3) The minimum unit static force on the drum(s) shall be 125 lb/in. (22 N/m); and
- (4) The minimum force on the oscillatory drum shall be 18,000 lb (80 kN).”; and
- (5) Self-adjusting eccentrics, and reversible eccentrics on non-driven drum(s).”

80399

## LIGHTS ON BARRICADES (BDE)

Effective: January 1, 2018

Revise Article 701.16 of the Standard Specifications to read:

**“701.16 Lights.** Lights shall be used on devices as required in the plans, the traffic control plan, and the following table.

Circumstance	Lights Required
Daylight operations	None
First two warning signs on each approach to the work involving a nighttime lane closure and “ROUGH GROOVED SURFACE” (W8-I107) signs	Flashing mono-directional lights
Devices delineating isolated obstacles, excavations, or hazards at night (Does not apply to patching)	Flashing bi-directional lights
Devices delineating obstacles, excavations, or hazards exceeding 100 ft (30 m) in length at night (Does not apply to widening)	Steady burn bi-directional lights
Channelizing devices for nighttime lane closures on two-lane roads	None
Channelizing devices for nighttime lane closures on multi-lane roads	None
Channelizing devices for nighttime lane closures on multi-lane roads separating opposing directions of traffic	None
Channelizing devices for nighttime along lane shifts on multilane roads	Steady burn mono-directional lights
Channelizing devices for night time along lane shifts on two lane roads	Steady burn bi-directional lights
Devices in nighttime lane closure tapers on Standards 701316 and 701321	Steady burn bi-directional lights
Devices in nighttime lane closure tapers	Steady burn mono-directional lights
Devices delineating a widening trench	None
Devices delineating patches at night on roadways with an ADT less than 25,000	None
Devices delineating patches at night on roadways with an ADT of 25,000 or more	None

Batteries for the lights shall be replaced on a group basis at such times as may be specified by the Engineer.”

Delete the fourth sentence of the first paragraph of Article 701.17(c)(2) of the Standard Specifications.

Revise the first paragraph of Article 603.07 of the Standard Specifications to read:

**“603.07 Protection Under Traffic.** After the casting has been adjusted and Class SI concrete has been placed, the work shall be protected by a barricade for at least 72 hours.”

80392

## **PAYMENTS TO SUBCONTRACTORS (BDE)**

Effective: November 2, 2017

Add the following to the end of the fourth paragraph of Article 109.11 of the Standard Specifications:

“If reasonable cause is asserted, written notice shall be provided to the applicable subcontractor and/or material supplier and the Engineer within five days of the Contractor receiving payment. The written notice shall identify the contract number, the subcontract or material purchase agreement, a detailed reason for refusal, the value of payment being withheld, and the specific remedial actions required of the subcontractor and/or material supplier so that payment can be made.”

80390



**PORTLAND CEMENT CONCRETE (BDE)**

Effective: November 1, 2017

Revise the Air Content % of Class PP Concrete in Table 1 Classes of Concrete and Mix Design Criteria in Article 1020.04 of the Standard Specifications to read:

"TABLE 1. CLASSES OF CONCRETE AND MIX DESIGN CRITERIA		
Class of Conc.	Use	Air Content %
PP	Pavement Patching Bridge Deck Patching (10)	
	PP-1	4.0 - 8.0"
	PP-2	
	PP-3	
	PP-4	
	PP-5	

Revise Note (4) at the end of Table 1 Classes of Concrete and Mix Design Criteria in Article 1020.04 of the Standard Specifications to read:

“(4) For all classes of concrete, the maximum slump may be increased to 7 in (175 mm) when a high range water-reducing admixture is used. For Class SC, the maximum slump may be increased to 8 in. (200 mm). For Class PS, the maximum slump may be increased to 8 1/2 in. (215 mm) if the high range water-reducing admixture is the polycarboxylate type.”

80389

## RECLAIMED ASPHALT PAVEMENT AND RECLAIMED ASPHALT SHINGLES (BDE)

Effective: November 1, 2012

Revise: January 1, 2019

Revise Section 1031 of the Standard Specifications to read:

### **“SECTION 1031. RECLAIMED ASPHALT PAVEMENT AND RECLAIMED ASPHALT SHINGLES**

**1031.01 Description.** Reclaimed asphalt pavement and reclaimed asphalt shingles shall be according to the following.

- (a) Reclaimed Asphalt Pavement (RAP). RAP is the material produced by cold milling or crushing an existing hot-mix asphalt (HMA) pavement. The Contractor shall supply written documentation that the RAP originated from routes or airfields under federal, state, or local agency jurisdiction.
- (b) Reclaimed Asphalt Shingles (RAS). Reclaimed asphalt shingles (RAS). RAS is from the processing and grinding of preconsumer or post-consumer shingles. RAS shall be a clean and uniform material with a maximum of 0.5 percent unacceptable material, as defined in Central Bureau of Materials Policy Memorandum, “Reclaimed Asphalt Shingle (RAS) Sources”, by weight of RAS. All RAS used shall come from a Central Bureau of Materials approved processing facility where it shall be ground and processed to 100 percent passing the 3/8 in. (9.5 mm) sieve and 93 percent passing the #4 (4.75 mm) sieve based on a dry shake gradation. RAS shall be uniform in gradation and asphalt binder content and shall meet the testing requirements specified herein. In addition, RAS shall meet the following Type 1 or Type 2 requirements.
  - (1) Type 1. Type 1 RAS shall be processed, preconsumer asphalt shingles salvaged from the manufacture of residential asphalt roofing shingles.
  - (2) Type 2. Type 2 RAS shall be processed post-consumer shingles only, salvaged from residential, or four unit or less dwellings not subject to the National Emission Standards for Hazardous Air Pollutants (NESHAP).

**1031.02 Stockpiles.** RAP and RAS stockpiles shall be according to the following.

- (a) RAP Stockpiles. The Contractor shall construct individual, sealed RAP stockpiles meeting one of the following definitions. No additional RAP shall be added to the pile after the pile has been sealed. Stockpiles shall be sufficiently separated to prevent intermingling at the base. Stockpiles shall be identified by signs indicating the type as listed below (i.e. “Homogeneous Surface”).

Prior to milling, the Contractor shall request the District provide documentation on the quality of the RAP to clarify the appropriate stockpile.

- (1) Fractionated RAP (FRAP). FRAP shall consist of RAP from Class I, HMA (High and Low ESAL) mixtures. The coarse aggregate in FRAP shall be crushed aggregate and may represent more than one aggregate type and/or quality, but shall be at least C quality. All FRAP shall be fractionated prior to testing by screening into a minimum of two size fractions with the separation occurring on or between the #4 (4.75 mm) and 1/2 in. (12.5 mm) sieves. Agglomerations shall be minimized such that 100 percent of the RAP shall pass the sieve size specified below for the mix into which the FRAP will be incorporated.

Mixture FRAP will be used in:	Sieve Size that 100 % of FRAP Shall Pass
IL-19.0	1 1/2 in. (40 mm)
IL-9.5	3/4 in. (20 mm)
IL-4.75	1/2 in. (13 mm)

- (2) Homogeneous. Homogeneous RAP stockpiles shall consist of RAP from Class I, HMA (High and Low ESAL) mixtures and represent: 1) the same aggregate quality, but shall be at least C quality; 2) the same type of crushed aggregate (either crushed natural aggregate, ACBF slag, or steel slag); 3) similar gradation; and 4) similar asphalt binder content. If approved by the Engineer, combined single pass surface/binder millings may be considered "homogeneous" with a quality rating dictated by the lowest coarse aggregate quality present in the mixture.
- (3) Conglomerate. Conglomerate RAP stockpiles shall consist of RAP from Class I, HMA (High and Low ESAL) mixtures. The coarse aggregate in this RAP shall be crushed aggregate and may represent more than one aggregate type and/or quality, but shall be at least C quality. This RAP may have an inconsistent gradation and/or asphalt binder content prior to processing. All conglomerate RAP shall be processed prior to testing by crushing to where all RAP shall pass the 5/8 in. (16 mm) or smaller screen. Conglomerate RAP stockpiles shall not contain steel slag.
- (4) Non-Quality. RAP stockpiles that do not meet the requirements of the stockpile categories listed above shall be classified as "Non-Quality".

RAP/FRAP containing contaminants, such as earth, brick, sand, concrete, sheet asphalt, bituminous surface treatment (i.e. chip seal), pavement fabric, joint sealants, etc., will be unacceptable unless the contaminants are removed to the satisfaction of the Engineer. Sheet asphalt shall be stockpiled separately.

- (b) RAS Stockpiles. Type 1 and Type 2 RAS shall be stockpiled separately and shall not be intermingled. Each stockpile shall be signed indicating what type of RAS is present.

Unless otherwise specified by the Engineer, mechanically blending manufactured sand (FM 20 or FM 22) up to an equal weight of RAS with the processed RAS will be permitted to improve workability. The sand shall be "B Quality" or better from an

approved Aggregate Gradation Control System source. The sand shall be accounted for in the mix design and during HMA production.

Records identifying the shingle processing facility supplying the RAS, RAS type, and lot number shall be maintained by project contract number and kept for a minimum of three years.

**1031.03 Testing.** RAP/FRAP and RAS testing shall be according to the following.

(a) RAP/FRAP Testing. When used in HMA, the RAP/FRAP shall be sampled and tested either during or after stockpiling.

(1) During Stockpiling. For testing during stockpiling, washed extraction samples shall be run at the minimum frequency of one sample per 500 tons (450 metric tons) for the first 2000 tons (1800 metric tons) and one sample per 2000 tons (1800 metric tons) thereafter. A minimum of five tests shall be required for stockpiles less than 4000 tons (3600 metric tons).

(2) After Stockpiling. For testing after stockpiling, the Contractor shall submit a plan for approval to the District proposing a satisfactory method of sampling and testing the RAP/FRAP pile either in-situ or by restockpiling. The sampling plan shall meet the minimum frequency required above and detail the procedure used to obtain representative samples throughout the pile for testing.

Each sample shall be split to obtain two equal samples of test sample size. One of the two test samples from the final split shall be labeled and stored for Department use. The Contractor shall extract the other test sample according to Department procedure. The Engineer reserves the right to test any sample (split or Department-taken) to verify Contractor test results.

(b) RAS Testing. RAS or RAS blended with manufactured sand shall be sampled and tested during stockpiling according to Central Bureau of Materials Policy Memorandum, "Reclaimed Asphalt Shingle (RAS) Source".

Samples shall be collected during stockpiling at the minimum frequency of one sample per 200 tons (180 metric tons) for the first 1000 tons (900 metric tons) and one sample per 250 tons (225 metric tons) thereafter. A minimum of five samples are required for stockpiles less than 1000 tons (900 metric tons). Once a  $\leq 1000$  ton (900 metric ton), five-sample/test stockpile has been established it shall be sealed. Additional incoming RAS or RAS blended with manufactured sand shall be stockpiled in a separate working pile as designated in the Quality Control plan and only added to the sealed stockpile when the test results of the working pile are complete and are found to meet the tolerances specified herein for the original sealed RAS stockpile.

Before testing, each sample shall be split to obtain two test samples. One of the two test samples from the final split shall be labeled and stored for Department use. The

Contractor shall perform a washed extraction and test for unacceptable materials on the other test sample according to Department procedures. The Engineer reserves the right to test any sample (split or Department-taken) to verify Contractor test results.

If the sampling and testing was performed at the shingle processing facility in accordance with the QC Plan, the Contractor shall obtain and make available all of the test results from start of the initial stockpile.

**1031.04 Evaluation of Tests.** Evaluation of test results shall be according to the following.

- (a) Evaluation of RAP/FRAP Test Results. All of the extraction results shall be compiled and averaged for asphalt binder content and gradation, and when applicable  $G_{mm}$ . Individual extraction test results, when compared to the averages, will be accepted if within the tolerances listed below.

Parameter	FRAP/Homogeneous/ Conglomerate
1 in. (25 mm)	
1/2 in. (12.5 mm)	± 8 %
No. 4 (4.75 mm)	± 6 %
No. 8 (2.36 mm)	± 5 %
No. 16 (1.18 mm)	
No. 30 (600 μm)	± 5 %
No. 200 (75 μm)	± 2.0 %
Asphalt Binder	± 0.4 % <sup>1/</sup>
$G_{mm}$	± 0.03

1/ The tolerance for FRAP shall be ± 0.3 %.

If more than 20 percent of the individual sieves and/or asphalt binder content tests are out of the above tolerances, the RAP/FRAP shall not be used in HMA unless the RAP/FRAP representing the failing tests is removed from the stockpile. All test data and acceptance ranges shall be sent to the District for evaluation.

With the approval of the Engineer, the ignition oven may be substituted for extractions according to the ITP, "Calibration of the Ignition Oven for the Purpose of Characterizing Reclaimed Asphalt Pavement (RAP)".

- (b) Evaluation of RAS and RAS Blended with Manufactured Sand Test Results. All of the test results, with the exception of percent unacceptable materials, shall be compiled and averaged for asphalt binder content and gradation. Individual test results, when compared to the averages, will be accepted if within the tolerances listed below.

Parameter	RAS
No. 8 (2.36 mm)	± 5 %

No. 16 (1.18 mm)	± 5 %
No. 30 (600 µm)	± 4 %
No. 200 (75 µm)	± 2.0 %
Asphalt Binder Content	± 1.5 %

If more than 20 percent of the individual sieves and/or asphalt binder content tests are out of the above tolerances, or if the percent unacceptable material exceeds 0.5 percent by weight of material retained on the # 4 (4.75 mm) sieve, the RAS or RAS blend shall not be used in Department projects. All test data and acceptance ranges shall be sent to the District for evaluation.

**1031.05 Quality Designation of Aggregate in RAP/FRAP.**

(a) RAP. The aggregate quality of the RAP for homogeneous and conglomerate stockpiles shall be set by the lowest quality of coarse aggregate in the RAP stockpile and are designated as follows.

(1) RAP from Class I, Superpave/HMA (High ESAL), or (Low ESAL) IL-9.5L surface mixtures are designated as containing Class B quality coarse aggregate.

(2) RAP from Class I binder, Superpave/HMA (High ESAL) binder, or (Low ESAL) IL-19.0L binder mixtures are designated as containing Class C quality coarse aggregate.

(b) FRAP. If the Engineer has documentation of the quality of the FRAP aggregate, the Contractor shall use the assigned quality provided by the Engineer.

If the quality is not known, the quality shall be determined as follows. Coarse and fine FRAP stockpiles containing plus #4 (4.75 mm) sieve coarse aggregate shall have a maximum tonnage of 5000 tons (4500 metric tons). The Contractor shall obtain a representative sample witnessed by the Engineer. The sample shall be a minimum of 50 lb (25 kg). The sample shall be extracted according to Illinois Modified AASHTO T 164 by a consultant laboratory prequalified by the Department for the specified testing. The consultant laboratory shall submit the test results along with the recovered aggregate to the District Office. The cost for this testing shall be paid by the Contractor. The District will forward the sample to the Central Bureau of Materials Aggregate Lab for MicroDeval Testing, according to ITP 327. A maximum loss of 15.0 percent will be applied for all HMA applications.

**1031.06 Use of RAP/FRAP and/or RAS in HMA.** The use of RAP/FRAP and/or RAS shall be the Contractor’s option when constructing HMA in all contracts.

(a) RAP/FRAP. The use of RAP/FRAP in HMA shall be as follows.

(1) Coarse Aggregate Size. The coarse aggregate in all RAP shall be equal to or less than the nominal maximum size requirement for the HMA mixture to be produced.

- (2) Steel Slag Stockpiles. Homogeneous RAP stockpiles containing steel slag will be approved for use in all HMA (High ESAL and Low ESAL) Surface and Binder Mixture applications.
  - (3) Use in HMA Surface Mixtures (High and Low ESAL). RAP/FRAP stockpiles for use in HMA surface mixtures (High and Low ESAL) shall be FRAP or homogeneous in which the coarse aggregate is Class B quality or better. FRAP from Conglomerate stockpiles shall be considered equivalent to limestone for frictional considerations. Known frictional contributions from plus #4 (4.75 mm) homogeneous FRAP stockpiles will be accounted for in meeting frictional requirements in the specified mixture.
  - (4) Use in HMA Binder Mixtures (High and Low ESAL), HMA Base Course, and HMA Base Course Widening. RAP/FRAP stockpiles for use in HMA binder mixtures (High and Low ESAL), HMA base course, and HMA base course widening shall be FRAP, homogeneous, or conglomerate, in which the coarse aggregate is Class C quality or better.
  - (5) Use in Shoulders and Subbase. RAP/FRAP stockpiles for use in HMA shoulders and stabilized subbase (HMA) shall be FRAP, homogeneous, or conglomerate.
  - (6) When the Contractor chooses the RAP option, the percentage of RAP shall not exceed the amounts indicated in Article 1031.06(c)(1) below for a given Ndesign.
- (b) RAS. RAS meeting Type 1 or Type 2 requirements will be permitted in all HMA applications as specified herein.
  - (c) RAP/FRAP and/or RAS Usage Limits. Type 1 or Type 2 RAS may be used alone or in conjunction with RAP or FRAP in HMA mixtures up to a maximum of 5.0 percent by weight of the total mix.
- (1) RAP/RAS. When RAP is used alone or RAP is used in conjunction with RAS, the percentage of virgin asphalt binder replacement shall not exceed the amounts listed in the Max RAP/RAS ABR table listed below for the given Ndesign.

**RAP/RAS Maximum Asphalt Binder Replacement (ABR) Percentage**

HMA Mixtures <i>1, 2/</i>	RAP/RAS Maximum ABR %		
	Binder/Leveling Binder	Surface	Polymer Modified
30	30	30	10
50	25	15	10
70	15	10	10
90	10	10	10

- 1/ For Low ESAL HMA shoulder and stabilized subbase, the RAP/RAS ABR shall not exceed 50 percent of the mixture.
  - 2/ When RAP/RAS ABR exceeds 20 percent, the high and low virgin asphalt binder grades shall each be reduced by one grade (i.e. 25 percent ABR would require a virgin asphalt binder grade of PG 64-22 to be reduced to a PG 58-28). If warm mix asphalt (WMA) technology is utilized and production temperatures do not exceed 275 °F (135 °C), the high and low virgin asphalt binder grades shall each be reduced by one grade when RAP/RAS ABR exceeds 25 percent (i.e. 26 percent RAP/RAS ABR would require a virgin asphalt binder grade of PG 64-22 to be reduced to a PG 58-28).
- (2) FRAP/RAS. When FRAP is used alone or FRAP is used in conjunction with RAS, the percentage of virgin asphalt binder replacement shall not exceed the amounts listed in the FRAP/RAS table listed below for the given Ndesign.

**FRAP/RAS Maximum Asphalt Binder Replacement (ABR) Percentage**

HMA Mixtures <i>1/, 2/</i>	FRAP/RAS Maximum ABR %						
	Ndesign	Binder/Leveling Binder		Surface		Polymer Modified	
		w/o I-FIT	with I-FIT	w/o I-FIT	with I-FIT	w/o I-FIT	with I-FIT
30	50	55	40	45	10	15	
50	40	45	35	40	10	15	
70	40	45	30	35	10	15	
90	40	45	30	35	10	15	
SMA	--	--	--	--	20	25	
IL-4.75	--	--	--	--	30	35	

- 1/ For Low ESAL HMA shoulder and stabilized subbase, the FRAP/RAS ABR shall not exceed 50 percent of the mixture.
- 2/ When FRAP/RAS ABR exceeds 20 percent for all mixes, the high and low virgin asphalt binder grades shall each be reduced by one grade (i.e. 25 percent ABR would require a virgin asphalt binder grade of PG 64-22 to be reduced to a PG 58-28). If warm mix asphalt (WMA) technology is utilized and production temperatures do not exceed 275 °F (135 °C), the high and low virgin asphalt binder grades shall each be reduced by one grade when FRAP/RAS ABR exceeds 25 percent (i.e. 26 percent ABR would require a virgin asphalt binder grade of PG 64-22 to be reduced to a PG 58-28).

**1031.07 HMA Mix Designs.** At the Contractor's option, HMA mixtures may be constructed utilizing RAP/FRAP and/or RAS material meeting the detailed requirements specified herein.



- (a) RAP/FRAP and/or RAS. RAP/FRAP and/or RAS mix designs shall be submitted for verification. If additional RAP/FRAP and/or RAS stockpiles are tested and found that no more than 20 percent of the results, as defined under “Testing” herein, are outside of the control tolerances set for the original RAP/FRAP and/or RAS stockpile and HMA mix design, and meets all of the requirements herein, the additional RAP/FRAP and/or RAS stockpiles may be used in the original mix design at the percent previously verified.
- (b) RAS. Type 1 and Type 2 RAS are not interchangeable in a mix design.

The RAP, FRAP, and RAS stone bulk specific gravities ( $G_{sb}$ ) shall be according to the “Determination of Aggregate Bulk (Dry) Specific Gravity ( $G_{sb}$ ) of Reclaimed Asphalt Pavement (RAP) and Reclaimed Asphalt Shingles (RAS)” procedure in the Department’s Manual of Test Procedures for Materials.

**1031.08 HMA Production.** HMA production utilizing RAP/FRAP and/or RAS shall be as follows.

- (a) RAP/FRAP. The coarse aggregate in all RAP/FRAP used shall be equal to or less than the nominal maximum size requirement for the HMA mixture being produced.

To remove or reduce agglomerated material, a scalping screen, gator, crushing unit, or comparable sizing device approved by the Engineer shall be used in the RAP feed system to remove or reduce oversized material.

If the RAP/FRAP control tolerances or QC/QA test results require corrective action, the Contractor shall cease production of the mixture containing RAP/FRAP and either switch to the virgin aggregate design or submit a new RAP/FRAP design.

- (b) RAS. RAS shall be incorporated into the HMA mixture either by a separate weight depletion system or by using the RAP weigh belt. Either feed system shall be interlocked with the aggregate feed or weigh system to maintain correct proportions for all rates of production and batch sizes. The portion of RAS shall be controlled accurately to within  $\pm 0.5$  percent of the amount of RAS utilized. When using the weight depletion system, flow indicators or sensing devices shall be provided and interlocked with the plant controls such that the mixture production is halted when RAS flow is interrupted.

- (c) RAP/FRAP and/or RAS. HMA plants utilizing RAP/FRAP and/or RAS shall be capable of automatically recording and printing the following information.

(1) Dryer Drum Plants.

- a. Date, month, year, and time to the nearest minute for each print.
- b. HMA mix number assigned by the Department.

- c. Accumulated weight of dry aggregate (combined or individual) in tons (metric tons) to the nearest 0.1 ton (0.1 metric ton).
- d. Accumulated dry weight of RAP/FRAP/RAS in tons (metric tons) to the nearest 0.1 ton (0.1 metric ton).
- e. Accumulated mineral filler in revolutions, tons (metric tons), etc. to the nearest 0.1 unit.
- f. Accumulated asphalt binder in gallons (liters), tons (metric tons), etc. to the nearest 0.1 unit.
- g. Residual asphalt binder in the RAP/FRAP material as a percent of the total mix to the nearest 0.1 percent.
- h. Aggregate and RAP/FRAP moisture compensators in percent as set on the control panel. (Required when accumulated or individual aggregate and RAP/FRAP are printed in wet condition.)

(2) Batch Plants.

- a. Date, month, year, and time to the nearest minute for each print.
- b. HMA mix number assigned by the Department.
- c. Individual virgin aggregate hot bin batch weights to the nearest pound (kilogram).
- d. Mineral filler weight to the nearest pound (kilogram).
- e. RAP/FRAP/RAS weight to the nearest pound (kilogram).
- f. Virgin asphalt binder weight to the nearest pound (kilogram).
- g. Residual asphalt binder in the RAP/FRAP/RAS material as a percent of the total mix to the nearest 0.1 percent.

The printouts shall be maintained in a file at the plant for a minimum of one year or as directed by the Engineer and shall be made available upon request. The printing system will be inspected by the Engineer prior to production and verified at the beginning of each construction season thereafter.

**1031.09 RAP in Aggregate Surface Course and Aggregate Wedge Shoulders, Type B.**

The use of RAP in aggregate surface course (temporary access entrances only) and aggregate wedge shoulders, Type B shall be as follows.

- (a) Stockpiles and Testing. RAP stockpiles may be any of those listed in Article 1031.02, except “Non-Quality” and “FRAP”. The testing requirements of Article 1031.03 shall not apply. RAP used shall be according to the current Central Bureau of Materials Policy Memorandum, “Reclaimed Asphalt Pavement (RAP) for Aggregate Applications”.
- (b) Gradation. One hundred percent of the RAP material shall pass the 1 1/2 in. (37.5 mm) sieve. The RAP material shall be reasonably well graded from coarse to fine. RAP material that is gap-graded or single sized will not be accepted.”

80306

## **TRAFFIC CONTROL DEVICES - CONES (BDE)**

Effective: January 1, 2019

Revise Article 701.15(a) of the Standard Specifications to read:

“(a) Cones. Cones are used to channelize traffic. Cones used to channelize traffic at night shall be reflectorized; however, cones shall not be used in nighttime lane closure tapers or nighttime lane shifts.”

Revise Article 1106.02(b) of the Standard Specifications to read:

“(b) Cones. Cones shall be predominantly orange. Cones used at night that are 28 to 36 in. (700 to 900 mm) in height shall have two white circumferential stripes. If non-reflective spaces are left between the stripes, the spaces shall be no more than 2 in. (50mm) in width. Cones used at night that are taller than 36 in. (900 mm) shall have a minimum of two white and two fluorescent orange alternating, circumferential stripes with the top stripe being fluorescent orange. If non-reflective spaces are left between the stripes, the spaces shall be no more than 3 in. (75 mm) in width.

The minimum weights for the various cone heights shall be 4 lb for 18 in. (2 kg for 450 mm), 7 lb for 28 in. (3 kg for 700 mm), and 10 lb for 36 in. (5 kg for 900 mm) with a minimum of 60 percent of the total weight in the base. Cones taller than 36 in. shall be weighted per the manufacturer’s specifications such that they are not moved by wind or passing traffic.”

80409

**Kendall County  
Prevailing Wage Rates**

Effective Date	County	Trade Title	Region	Type	Class	Base Wage	Foreman Wage	OT M-F	OT Sa	OT Su	OT Hol	H/W	Pension	Vacation	Training	Other Fringe Benefit
8/15/2018	Kendall	ASBESTOS ABT-GEN	All	ALL		42.72	43.72	1.5	1.5	2	2	13.77	13.7	0	0.72	0
11/5/2018	Kendall	ASBESTOS ABT-MEC	All	BLD		37.88	40.38	1.5	1.5	2	2	12.92	11.82	0	0.72	0
8/15/2018	Kendall	BOILERMAKER	All	BLD		49.46	53.91	2	2	2	2	6.97	20.41	0	0.4	0
8/15/2018	Kendall	BRICK MASON	All	BLD		46.19	50.81	1.5	1.5	2	2	10.65	17.92	0	0.92	0
4/5/2019	Kendall	CARPENTER	All	ALL		47.35	49.35	1.5	1.5	2	2	11.79	20.42	0	0.63	0
2/22/2019	Kendall	CEMENT MASON	All	ALL		45.89	47.89	2	1.5	2	2	10.25	22.01	0	0.5	0
8/15/2018	Kendall	CERAMIC TILE FNSHER	All	BLD		39.56	39.56	1.5	1.5	2	2	10.75	12.02	0	0.77	0
4/5/2019	Kendall	COMMUNICATION TECH	All	BLD		40.12	42.52	1.5	1.5	2	2	13.31	11.23	0	1.4	0
8/15/2018	Kendall	ELECTRIC PWR EQMT OP	All	ALL		42.59	57.95	1.5	1.5	2	2	5.75	13.21	0	0.75	0
8/15/2018	Kendall	ELECTRIC PWR EQMT OP	All	HWY		41.45	56.38	1.5	1.5	2	2	5.5	12.87	0	0.73	0
8/15/2018	Kendall	ELECTRIC PWR GRNDMAN	All	ALL		32.86	57.95	1.5	1.5	2	2	5.75	10.2	0	0.58	0
8/15/2018	Kendall	ELECTRIC PWR GRNDMAN	All	HWY		32	56.38	1.5	1.5	2	2	5.5	9.92	0	0.66	0
8/15/2018	Kendall	ELECTRIC PWR LINEMAN	All	ALL		51.06	57.95	1.5	1.5	2	2	5.75	15.85	0	0.9	0
8/15/2018	Kendall	ELECTRIC PWR LINEMAN	All	HWY		49.67	56.38	1.5	1.5	2	2	5.5	15.4	0	0.88	0
8/15/2018	Kendall	ELECTRIC PWR TRK DRV	All	ALL		34.03	57.95	1.5	1.5	2	2	5.75	10.55	0	0.6	0
8/15/2018	Kendall	ELECTRIC PWR TRK DRV	All	HWY		33.14	56.38	1.5	1.5	2	2	5.5	10.29	0	0.59	0
4/5/2019	Kendall	ELECTRICIAN	All	BLD		47.72	51.97	1.5	1.5	2	2	17.36	13.36	0	1.67	0
8/15/2018	Kendall	ELEVATOR CONSTRUCTOR	All	BLD		54.85	61.71	2	2	2	2	15.43	16.61	4.38	0.61	0
8/15/2018	Kendall	FENCE ERECTOR	All	ALL		45.56	49.2	2	2	2	2	11.02	21.51	0	0.7	0
2/8/2019	Kendall	GLAZIER	All	BLD		43.85	45.35	1.5	2	2	2	14.17	21.11	0	0.94	0
11/5/2018	Kendall	HT/FROST INSULATOR	All	BLD		50.5	53	1.5	1.5	2	2	12.92	13.16	0	0.72	0
4/5/2019	Kendall	IRON WORKER	All	ALL		45.84	49.51	2	2	2	2	11.77	22.9	0	0.83	0
4/18/2019	Kendall	LABORER	All	ALL		42.72	43.47	1.5	1.5	2	2	13.77	13.7	0	0.72	0
8/15/2018	Kendall	LATHER	All	ALL		47.35	49.35	1.5	1.5	2	2	11.79	20.42	0	0.63	0
8/15/2018	Kendall	MACHINIST	All	BLD		48.38	50.88	1.5	1.5	2	2	7.23	8.95	1.85	1.47	0
8/15/2018	Kendall	MARBLE FINISHERS	All	ALL		34.65	47.7	1.5	1.5	2	2	10.65	16.46	0	0.49	0
8/15/2018	Kendall	MARBLE MASON	All	BLD		45.43	49.97	1.5	1.5	2	2	10.65	17.39	0	0.61	0
11/9/2018	Kendall	MATERIAL TESTER I	All	ALL		32.72	32.72	1.5	1.5	2	2	13.77	13.7	0	0.72	0
11/9/2018	Kendall	MATERIALS TESTER II	All	ALL		37.72	37.72	1.5	1.5	2	2	13.77	13.7	0	0.72	0
8/15/2018	Kendall	MILLWRIGHT	All	ALL		47.35	49.35	1.5	1.5	2	2	11.79	20.42	0	0.63	0
10/26/2018	Kendall	OPERATING ENGINEER	All	BLD	1	51.1	55.1	2	2	2	2	19.65	15.1	2	1.4	0
8/15/2018	Kendall	OPERATING ENGINEER	All	BLD	2	49.8	55.1	2	2	2	2	19.65	15.1	2	1.4	0
8/15/2018	Kendall	OPERATING ENGINEER	All	BLD	3	47.25	55.1	2	2	2	2	19.65	15.1	2	1.4	0
8/15/2018	Kendall	OPERATING ENGINEER	All	BLD	4	45.5	55.1	2	2	2	2	19.65	15.1	2	1.4	0
8/15/2018	Kendall	OPERATING ENGINEER	All	BLD	5	54.85	55.1	2	2	2	2	19.65	15.1	2	1.4	0
8/15/2018	Kendall	OPERATING ENGINEER	All	BLD	6	52.1	55.1	2	2	2	2	19.65	15.1	2	1.4	0
8/15/2018	Kendall	OPERATING ENGINEER	All	BLD	7	54.1	55.1	2	2	2	2	19.65	15.1	2	1.4	0
8/15/2018	Kendall	OPERATING ENGINEER	All	FLT		38	38	1.5	1.5	2	2	18.8	14.35	2	1.3	0
11/5/2018	Kendall	OPERATING ENGINEER	All	HWY	1	49.3	53.3	1.5	1.5	2	2	19.65	15.1	2	1.4	0
8/15/2018	Kendall	OPERATING ENGINEER	All	HWY	2	48.75	53.3	1.5	1.5	2	2	19.65	15.1	2	1.4	0
8/15/2018	Kendall	OPERATING ENGINEER	All	HWY	3	46.7	53.3	1.5	1.5	2	2	19.65	15.1	2	1.4	0
4/5/2019	Kendall	OPERATING ENGINEER	All	HWY	4	45.3	53.3	1.5	1.5	2	2	19.65	15.1	2	1.4	0
4/5/2019	Kendall	OPERATING ENGINEER	All	HWY	5	44.1	53.3	1.5	1.5	2	2	19.65	15.1	2	1.4	0
8/15/2018	Kendall	OPERATING ENGINEER	All	HWY	6	52.3	53.3	1.5	1.5	2	2	19.65	15.1	2	1.4	0
8/15/2018	Kendall	OPERATING ENGINEER	All	HWY	7	50.3	53.3	1.5	1.5	2	2	19.65	15.1	2	1.4	0
8/15/2018	Kendall	ORNAMNTL IRON WORKER	All	ALL		45.56	49.2	2	2	2	2	11.02	21.51	0	0.7	0
8/15/2018	Kendall	PAINTER	All	ALL		45.28	47.28	1.5	1.5	1.5	1.5	11.55	8.2	0	1.35	0
8/15/2018	Kendall	PAINTER SIGNS	All	BLD		38.2	43.25	1.5	1.5	2	2	2.6	3.25	0	0	0
8/15/2018	Kendall	PILEDRIVER	All	ALL		47.35	49.35	1.5	1.5	2	2	11.79	20.42	0	0.63	0
1/11/2019	Kendall	PIPEFITTER	All	BLD		48.5	51.5	1.5	1.5	2	2	10.05	18.85	0	2.54	0
8/15/2018	Kendall	PLASTERER	All	BLD		43.25	45.85	1.5	1.5	2	2	14.25	16.69	0	1.35	0
4/18/2019	Kendall	PLUMBER	All	BLD		50.25	53.25	1.5	1.5	2	2	14.34	14.42	0	1.31	0
11/23/2018	Kendall	ROOFER	All	BLD		43.65	47.65	1.5	1.5	2	2	9.73	12.44	0	0.53	0
1/18/2019	Kendall	SHEETMETAL WORKER	All	BLD		48.02	50.42	1.5	1.5	2	2	10.75	16.19	0	1.03	3.5

**Kendall County  
Prevailing Wage Rates**

Effective Date	County	Trade Title	Region	Type	Class	Base Wage	Foreman Wage	OT M-F	OT Sa	OT Su	OT Hol	H/W	Pension	Vacation	Training	Other Fringe Benefit
4/5/2019	Kendall	SPRINKLER FITTER	All	BLD		48.1	50.6	1.5	1.5	2	2	13.25	15.9	0	0.55	0
8/15/2018	Kendall	STEEL ERECTOR	ALL	ALL		45.06	48.66	2	2	2	2	10.52	20.76	0	0.7	
8/15/2018	Kendall	STONE MASON	All	BLD		46.19	50.81	1.5	1.5	2	2	10.65	17.92	0	0.92	0
8/15/2018	Kendall	TERRAZZO FINISHER	All	BLD		41.54	41.54	1.5	1.5	2	2	10.75	13.71	0	0.86	0
8/15/2018	Kendall	TERRAZZO MASON	All	BLD		45.38	48.88	1.5	1.5	2	2	10.75	15.17	0	0.89	0
8/15/2018	Kendall	TILE MASON	All	BLD		46.49	50.49	1.5	1.5	2	2	10.75	14.99	0	0.9	0
4/5/2019	Kendall	TRUCK DRIVER	All	ALL	1	38.41	38.96	1.5	1.5	2	2	9.15	10.43	0	0.15	0
8/15/2018	Kendall	TRUCK DRIVER	All	ALL	2	38.56	38.96	1.5	1.5	2	2	9.15	10.43	0	0.15	0
4/5/2019	Kendall	TRUCK DRIVER	All	ALL	3	38.76	38.96	1.5	1.5	2	2	9.15	10.43	0	0.15	0
8/15/2018	Kendall	TRUCK DRIVER	All	ALL	4	38.96	38.96	1.5	1.5	2	2	9.15	10.43	0	0.15	0
8/15/2018	Kendall	TUCKPOINTER	All	BLD		46	47	1.5	1.5	2	2	8.34	16.81	0	0.93	0

# Street Map

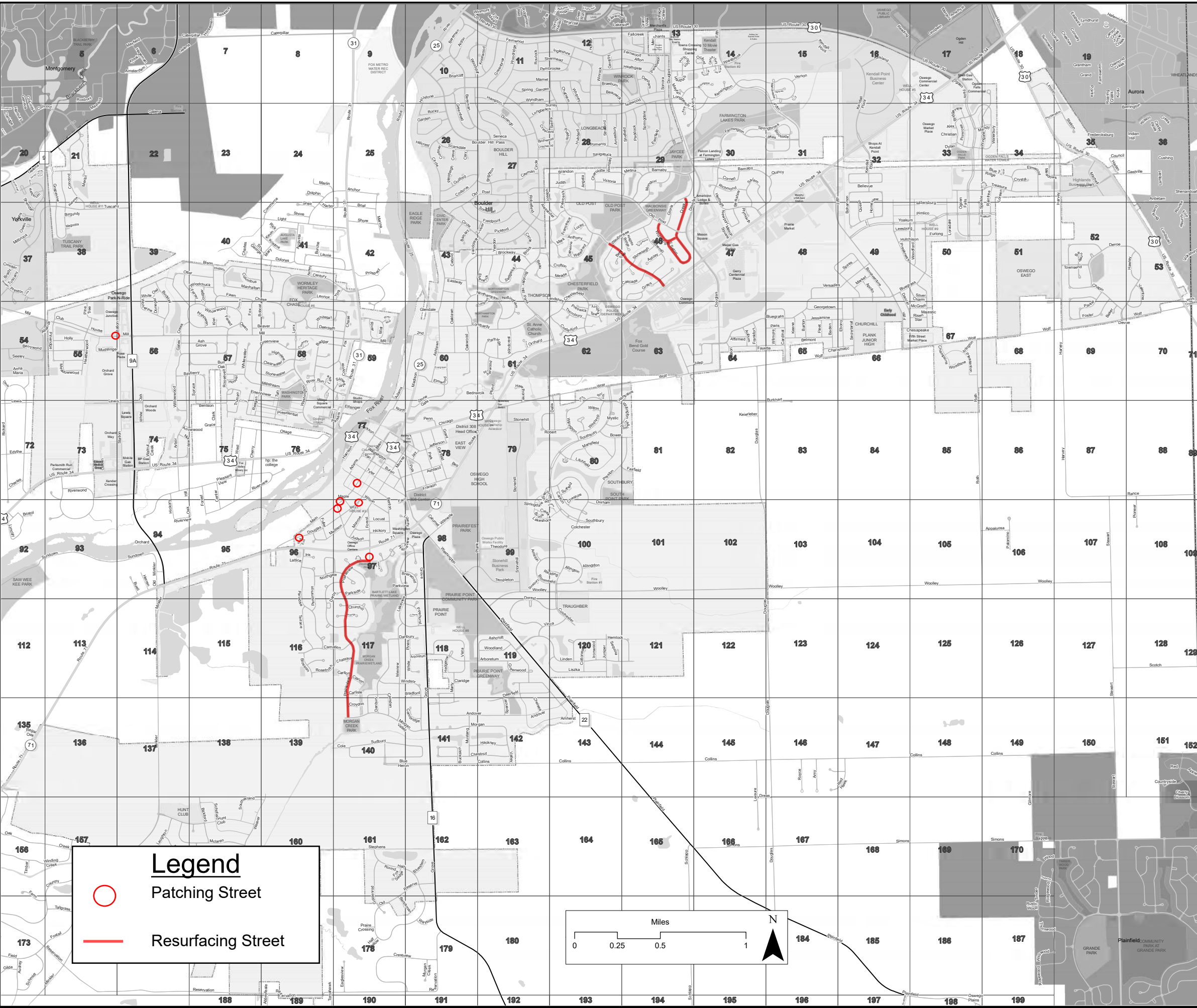

2nd St	60 Chesapeake Ln	86 Grande Trail Ct	72 Mayfield Ct	21 Sequoia Ct	120
Abbeyleafe Dr	100 Cheshire Ln	100 Grande Trl	72 Mayfield Ct	21 Seton Creek Dr	46
Abington Dr	189 Chesterfield Ct	18 Grant St	78 McGrath Dr	66 Settlers Ln	176
Adams St	77 Chesterfield Dr	62 Grantham Ln	19 McLaren Dr	158 Shadow Ct	99
Addison Ct	80 Chestnut Dr	41 Grapevine Trl	22 Meadows Ct	34 Shadowbrook Ct	79
Affirmed Ave	64 Chicago Rd	141 Grays Ct	46 Meadowdown Ln	13 Shell Ct	41
Afon Dr	13 Chipmunk Dr	53 Greenfield Rd	26 Merlot Ct	21 Shenandoah Pr	43
Alex Ct	43 Cispawpa Dr	109 Greenview Ct	38 Metina Dr	34 Sherwood Rd	36
Alexander Ct	45 Christian Ct	37 Greenview Ln	57 Mill Rd	51 Shore Ct	61
Alliance Xing	54 Churchill Ct	117 Greenwood Pl	119 Millersburg St	49 Shore Ct	41
Allington Ct	100 Church Hill Ln	96 Grove Rd	98 Millstream Ln	57 Shore Ct	28
Amesbury Rd	28 Ciderford Ct	62 Guilford Rd	157 Minkler Rd	42 Sierra Rd	28
Amethyst Ln	117 Ciderford Dr	62 H	26 Mist Dr	39 Silver Charm Dr	49
Amherst Cir	119 Circle Ct	44 Hackney Ln	41 Mitchell Dr	35 Simsby Ct	99
Amherst Ct	119 Circle Dr	26 Halenrichter Rd	19 Mondov Dr	46 Somers Rd	43
Amston Ct	99 Cation Dr	64 Half Hollow Ct	176 Monroe St	44 Sonora Dr	13
Anchor Rd	25 Clairie Dr	118 Half Moon Ct	34 Morgan Creek Ct	179 Southbury Blvd	80
Anderson Dr	141 Claron Ct	117 Half Round Rd	161 Morgan Valley Dr	140 Southland Dr	159
Angeles Cir	78 Clark Ave	75 Hampshire Ct	86 Mudslinger Rd	50 Sparkle Ct	50
Anna Maria Ln	54 Clay Ct	26 Hampton Rd	85 Mustang Dr	141 Spencer Ln	142
Anthony Ct	45 Cleanwater Ct	58 Hanover Ct	15 Mystic Ct	80 Spies Dr	49
Ardenham Ct	36 Cleanwater Ln	57 Harbor Dr	41 N	156 Springbrook Trl	30
Ardenham Dr	49 Club House Ln	55 Harlan Ave	35 N/Au Say Ct	189 Springdale Ct	99
Arbor Ct	74 Cobblestone Ct	14 Harrison St	77 Newport Cr	47 Springdale Rd	73
Arbor Ln	74 Codorus Rd	26 Hartford Ct	13 North St	77 Spruce St	15
Arboretum Way	118 Colchester Dr	80 Harvey Rd	34 Northampton Dr	43 St George Ln	40
Arlington Dr	119 Colonus Dr	40 Hawthorn Dr	59 Northampton Ct	96 St George Ln	66
Arrowwood Dr	74 Collins Rd	141 Hawley Dr	53 Northgate Dr	96 Steeplechase Blvd	49
Ash Grove Ln	56 Colony Ct	156 Hawthorne Dr	79 Norway Pl	74 Stephens Rd	160
Ashcroft Ct	119 Columbus Dr	40 Heathwood Dr	55 Nottingham Ct	61 Stillwater Ct	59
Ashcroft Ln	119 Columbus Rd	40 Heathwood Rd	44 Nottingham Dr	44 Stillwater Ct	78
Ashland St	43 Concord Ct	21 Hedgerow Ct	118 O	79 Stonehill Rd	79
Ashlan Ave	47 Concord Dr	19 Hedgerow Ln	118 Oak Creek Dr	156 Stoneleigh Ln	48
Ashley Cir	46 Conway Ln	19 Hemlock Ct	42 Oak Hill Dr	46 Stonemill Ln	46
Ashley Way	41 Cooldige Pl	75 Hermitage Ln	120 Oakman Ave	60 Strawnway Ln	57
Auburn Dr	64 Cornell Dr	30 Heritage G	30 Oakwood Dr	60 Stratford Dr	28
Augusta Ct	41 Cottonmaster Ave	120 Herren Ln	94 Obrien Way	73 Sudbury Cir	140
Anson Ct	13 Cottingham Ct	43 Hickory Ln	97 Old Falls Blvd	94 Sufferlin Dr	80
B	65 County Ave	35 Highland Ct	97 Old Post Rd	26 Sundown Ln	94
Baden Ave	58 Country Rd	156 Highview Ct	58 Old Reserve Rd	162 Sunshine Ct	28
Badger Ct	59 Cretan Ct	18 Hill Ave	18 Orchard Rd	60 Sunrye Dr	22
Baker Ct	69 Coyote Ct	59 Hillcrest Ct	26 Orchard Rd	72 T	58
Barclay Ct	43 Cranston Cir	72 Hillstone Rd	26 Osage Ct	27 Taft Dr	58
Barclayman Ct	29 Creek Dr	98 Hobbs Ln	72 Ottawa Ct	189 Tallgrass Ln	174
Barlowe Ct	29 Creskadee Ct	98 Hollenback Ct	72 Otter Way	189 Templeton Dr	13
Barrington Dr	35 Crescent Ct	27 Holly Ln	25 Oxford Ct	14 Terrace Ct	116
Baron Dr	65 Crestview Dr	178 Homeview Dr	49 P	116 Terrace Ln	116
Baumann Trl	21 Crestwood Rd	27 Hoover Dr	27 Paddock St	29 Tewksbury Cir	62
Bayberry Dr	56 Creve Ct	26 Hubbard Way	28 Paradise Pkwy	96 Tewksbury Ct	62
Beau Meade Rd	44 Crofton Ct	45 Hudson Dr	40 Paradise Pkwy	64 Theodore Dr	99
Beauregard Dr	28 Crofton Rd	44 Hunt Club Ct	159 Paris Ave	62 Thornbury Ct	62
Beaver Xing	57 Croydon Ct	140 Huntington Ct	13 Parker Pl	52 Thornbury Dr	62
Bednark Ct	78 Crystal Ct	34 Hutchison St	49 Parkers Mi	76 Timber Ct	156
Bellevue Ct	78 Culver Rd	43 Indian Hill Ln	35 Parkland Ct	98 Tomahawk Trl	189
Bellevue Cir	32 Curran Ct	28 Ingleshire Ln	28 Parkview Ct	80 Tomahawk Trl	80
Belmont Ave	65 Cushing Ln	36 Inghosen Ct	57 Parkways Sq	61 Townsend Dr	52
Bennett Ct	52 D	118 Inshoven Ct	35 Parceses Frd	45 Treasure Dr	61
Bent Tree Ct	45 Danbury Ct	117 Inshoven Ct	120 Pendleton Pl	13 Truman Dr	57
Benton St	77 Danbury Dr	117 Ironwood Ave	120 Penn Ct	76 Turtle Creek Dr	19
Benson St	75 Dancer Ln	66 Iroquois Ct	189 Penn Ct	98 Turtle Creek Dr	19
Berenson Rd	26 Davis Ct	54 Isleview Dr	117 Persimmon Ln	76 Turtle Creek Dr	19
Berkshire Ct	47 Deerfield Dr	19 J	117 Plund Ct	79 Tyler St	38
Berrywood Ln	54 Deepdash Dr	58 Jackson Pl	78 Pine Tree Ct	79 Tuscany Trl	77
Bickford Ave	159 Dela Ln	80 Jackson St	77 Pimlico St	49 U	49
Birchwood Ct	27 Denham Rd	13 Jay St	78 Pine Tree Ct	55 US Route 30	13
Bison Rd	39 Devon Ct	97 Jefferson St	77 Pinehurst Ln	118 US Route 34	17
Bison Rd	40 Devoe Dr	52 Jessamine Dr	65 Pinehurst Ln	117 V	117
Bloomfield Cir	99 Diamond Creek Ln	19 Joseph Ct	27 Pineridge Dr	55 Valentine Way	70
Bloomfield Ct	100 Dorset St	40 Judith Cir	27 Plainfield Rd	119 Van Buren St	77
Blossom Ct	116 Dorset St	56 Judson Ave	63 Pleasant View Dr	15 Vernon Dr	15
Blossom Ln	116 Dorchester Ct	97 Julep Ave	63 Pleasant View Dr	74 Versailles Pkwy	48
Blue Heron Dr	140 Dorset Ave	119 Juniper St	120 Pleasant View Dr	67 Vicksburg Ln	53
Blue Ridge Ct	33 Douglas Cir	13 Justice Dr	72 Plymouth Ct	47 Victoria Ln	28
Blue Ridge Dr	33 Douglas Ln	13 Justice Dr	72 Plymouth Ct	78 Village Center Pkwy	71
Bluegrass Pkwy	48 Douglas St	96 K	65 Pomeroy Rd	28 Vinca Ln	119
Bluestem Ct	162 Dunhill Ln	18 Keene Ave	65 Pomfret Ct	61 Vista Dr	118
Bobcat Ln	47 Durango Rd	100 Kellerfield Rd	62 Ponds Ct	58 Walnut Creek Ln	78
Bobcat Ct	58 Durham Ln	100 Kendall Point Dr	15 Poplar Ct	118 Walnut Creek Ln	78
Bohannon Cir	32 Dylan Dr	33 Kensington Dr	13 Pottowamie Ct	46 Washington St	58
Bolton Ct	62 E	178 Kent Ct	29 Prairie Crossing Rd	178 Waterbury Cir	35
Bowling Green Ln	48 Eaglesview Ln	37 Kevin Ln	411 Prairieview Ct	57 Waterford Ct	45
Boulder Hill Pass	26 Eastfield Rd	29 Kirkland Cir	32 Prairieview Dr	97 Waubensee Cir	45
Bower Ln	80 Eastway Dr	43 Kiwi Ct	57 Preakness Dr	49 Waubensee Circle Ct	45
Bradford Ct	118 Eastwick Ln	19 Knights Bridge Ct	46 Presidential Blvd	75 Wayside Ct	179
Braeburn Dr	13 Ebony Ct	68 Kristine St	41 Preston Dr	54 Weaver St	159
Brandon Ct	28 Edgebrook Ct	58 Kudu Dr	35 Preston Ln	80 Weaver St	159
Brianwood Ln	97 Edythe St	72 L	58 Preswick Ct	62 Wembley Rd	28
Bridgeway Dr	33 Eisenhower Dr	57 Lake Ct	58 Pimirose Ln	33 West Dr	75
Brighton Way	27 Ellsworth Ct	72 Lakeshore Dr	79 Proclamation Dr	34 West End Ct	96
Brook Ct	44 Ellsworth Dr	72 Lakeside Dr	13 Prospect Ln	42 Westford Pl	120
Brockway Dr	43 Elmwood Ave	34 Lakeview Ct	98 Pueblo Rd	28 Westleigh Ct	26
Bromfield Dr	14 Elmwood Dr	97 Lakewood Dr	67 Proclamation Dr	60 Westminster Ct	14
Brook Ct	99 Etsinger Rd	77 Lambert Dr	36 O	74 White Oak Dr	74
Brookside Dr	31 Evergreen Ct	60 Landshire Ct	62 Queen Dr	49 White Owl Ln	39
Buckingham Ct	14 F	80 Laticoe Dr	96 Quincey Dr	31 White Pines Ct	118
Buckland Dr	53 Fairfield Dr	80 Laughon Ave	158 R	50 White Pines Ln	118
Buckskin Dr	141 Fairview Dr	13 Laurie Ln	41 Raintree Dr	50 Whittell Xing	58
Bucktail Dr	39 Fallcreek Cir	13 Leesburg St	49 Reading Dr	16 Whitewater Ln	57
Budlong Rd	94 Farnad Ct	57 Lehman Xing	54 Reagan Dr	57 Whitney Way	28
Buella Rd	94 Farm Ct	174 Lennox Ct	42 Redding Ct	99 Wiesbrook Dr	13
Burche Dr	41 Farmington Lakes Dr	29 Lennox Dr	58 Regal Oak Ct	135 Willington Way	62
Burgundy Ct	38 Farnsworth Ave	19 Lewis St	72 Reliance Ct	21 Willowood Dr	56
Burkhardt Dr	82 Faro Ct	97 Liberty Ct	40 Reservation Rd	174 Wilmette Ave	56
Burr Oak Dr	57 Fawn Dr	40 Light Rd	35 Richmond Dr	30 Wilmore Dr	85
Butler St	158 Fayette Dr	64 Lincoln Station Dr	35 Richmond Dr	30 Wilson Creek Cir	36
C	Fernwood Dr	13 Linden Dr	119 Rick Ct	41 Wilson Pl	77
Calumet St	98 Ferret Xing	39 Licka Ln	419 Rickard Dr	54 Wilson Ct	80
Camden Dr	140 Fieldpoint Rd	43 Litchfield Way	80 Ridgefield Rd	44 Windcrest Dr	61
Canterbury Ct	14 Fifth St	63 Locust Ave	97 Risen Star Ln	67 Winding Creek Rd	156
Canton Ct	100 Fleet Dr	45 Lombardy Ln	60 River Mist Ct	59 Windsor Dr	117
Canton Dr	80 Flintlock Ct	46 Long Beach Rd	13 River Mist Dr	59 Wingate Ct	18
Canyon Creek Ct	19 Forest Ave	97 Longford Ct	60 River Run Blvd	58 Wingate Dr	34
Canyon Creek Dr	19 Forest Ct	95 Lorada Rd	50 River Run Ct	59 Winrock Rd	28
Cardinal Ave	64 Fort Sumter Ct	53 Lorenson Dr	34 Riverview Ct	75 Winthrop Dr	80
Carlisle Ct	117 Foster Dr	69 Lucky Ct	45 Riverwood Ln	73 Wolf Rd	62
Carlton Ct	117 Fox Chase Ct	59 Lundquist Dr	38 Roaring Creek Dr	73 Wolfs Crossing Rd	70
Carrington Ct	117 Fox Chase Dr	57 Lyndhurst Ln	58 Robert Rd	19 Wolmington Dr	46
Carpenter Ave	159 Fox Sedge Ct	161 M	36 Robinson Cir	79 Wolmington Dr	39
Carriage Ct	97 Fottall Ln	174 Madison Ct	96 Roosevelt Dr	26 Woodchuck Trl	39
Cascade Ln	45 Francesca Ct	45 Madison St	60 Rosebush Ln	57 Woodford Rd	50
Castle Pines Ln	36 Frankfort Ave	64 Magnolia Ct	38 Roth Rd	67 Woodland Way	119
Catherine Ct	47 Franklin St	77 Main St	37 Rourke Dr	36 Woodchuck Trl	39
Cayman Ct	27 Fredericksburg Ln	35 Majestic Ln	50 Route 25	60 Y	0
Cayman Dr	26 Fuller Ave	65 Manchester Rd	15 Route 31	25 Yeardon Dr	44
Cebold Dr	43 Furlong St	50 Mandy Ln	33 Route 71	78 Yeakum Blvd	44
Center Dr	95 G	21 Manhattan Cir	40 Roxbury Ln	21 York Dr	42
Century Dr	59 Galena Rd	26 Mansfield Ct	80 S		
Champions Run	67 Garfield St	78 Maple St	97 Salem Cir		
Chapin Way	52 Gasville St	35 Marina Dr	42 Saratoga Ct		
Chapman Dr	76 Gales Creek Dr	58 Mark Ct	45 Saugatuck Rd		
Charismatic Dr	65 Georgetown Dr	60 Market Dr	49 Scarsdale Rd		
Charles Ct	40 Glendale Ave	60 Marnel Rd	27 Schofield Dr		
Charles St	72 Gloria Ln	29 Marquis St	17 Seasons Ridge Blvd		
Charlotte Ln	28 Goldenrod Dr	178 Mary Ln	41 Secretariat Ln		
Chateaux Ct	117 Goodwin Dr	21 Mary St	41 Sedgwick Ct		
Chatham Pl	28 Grace St	75 Mason Square Dr	47 Sedgwick Rd		
Chelsea Ct	142 Grand Pointe Trl	35 Matlock Dr	54 Seeley St		
Cherry Dr	75 Grand View Pl	13 Mayfair Ct	13 Seneca Dr		

**Legend**

- Patching Street
- Resurfacing Street

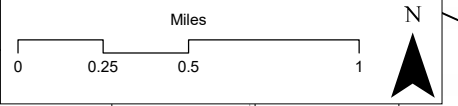

Date Created: 6/6/2014

The requested map will be created for study purposes only. Please refer to the official recorded plans or deeds for the actual legal descriptions and property dimensions. No liability is assumed for the accuracy of the data depicted or implied by the Village of Oswego or its employees. This work is produced by the United States Copyright Act of 1976 (17 USC Sec 107) and is not to be reproduced or distributed in any form or by any means, electronic or mechanical, including photocopying, recording, or by any information storage and retrieval system, without the prior written permission of the Village of Oswego. You are not permitted to use and/or reproduce any part of a copyrighted work of the Village of Oswego in violation of Federal Copyright Law. Doing so may result in prosecution under such law. If you wish to use any portion in which the Village of Oswego owns a copyright, you must obtain written permission through the Community Development Department in the Village of Oswego, located at 100 Parkers Mill, Oswego, Illinois 60543.

## **GENERAL NOTES**

### **WORK HOURS**

The Contractor must adhere to the Village ordinance work time schedule between the hours of 7:00 a.m. to 7:00 p.m. from Monday through Friday. No work may be performed prior or beyond this period without prior written approval from the Village.

### **WATER SUPPLY**

The indiscriminate use of fire hydrants, existing streams, creeks, wetlands, or ponds is strictly prohibited. The Contractor shall provide a water truck and driver as required to obtain and transport this water. The Contractor shall be responsible for obtaining water from an approved source. If this water is from a source other than his yard, written approval from the agency having jurisdiction for the source of the water must be received by the Contractor prior to use of the water.

### **PRECONSTRUCTION CONFERENCE**

A preconstruction conference shall be held at the Village of Oswego Public Works. The progress schedule shall be reviewed at that time. In addition, the Contractor shall provide a list of the intended source of materials and the intended list of subcontractors to be used with respect to the subject project.

### **APPLICATION FOR PAYMENT**

Application for payment to the Contractor shall be in accordance with the Standard Specifications and these Special Provisions. The Contractor will prepare invoices not more than once monthly.

The Contractor shall procure from each subcontractor and supplier of material or labor a waiver of any claim which they may have under the mechanics lien laws of the state in which the work is located, to insure the Village immunity from mechanics liens on subcontractors in carrying out the contract and any work orders for additions thereto, all as a condition of any payment by the Village. Any payments made by the Village without requiring compliance with this paragraph shall not be construed as a Waiver by the Village of the right to require compliance with this paragraph as a condition to later payments.

The Contractor shall submit Partial Waivers of Lien from all subcontractors and suppliers with each partial payment estimate and Contractor's Affidavit for subcontractors and suppliers with second payment request for the previous payment estimates and then with all subsequent payment estimates. The Contractor shall furnish with his final application for payment a complete release of all liens arising out of this contract, or receipts in full in lieu thereof and an affidavit that the releases and receipts include all labor and material for which a lien could be filed.

### **SUPPLEMENTAL SIGNS**

#### **NO PARKING SIGNS**

The Contractor shall be responsible for keeping vehicles off the streets as needed for the project. The Contractor shall install and maintain temporary signs in the parkway twenty-four (24) hours prior to starting work on each street. The signs shall read "NO PARKING, 7:00 AM – 7:00 PM" and state the day or days of the week work will be done. Immediately following each stage of work on each street, the Contractor shall remove the signs and reinstall them as needed.

#### **FRESH OIL SIGNS**

The Contractor shall be responsible for posting 'FRESH OIL' signs (48" X 48" minimum) as needed for the project. The Contractor shall install and maintain temporary signs in the parkway twenty-four (24) hours prior to placing prime coat on each street. The signs shall read "FRESH OIL, TRAVEL AT YOUR OWN RISK". The Contractor shall remove the signs and reinstall them as needed.

#### **ROAD CONSTRUCTION AHEAD SIGNS**

The Contractor shall be responsible for posting 'ROAD CONSTRUCTION AHEAD' signs (48" X 48" minimum) as needed for the project. The Contractor shall install and maintain temporary signs in the



parkway seventy-two (72) hours prior to beginning work in a particular area or subdivision. The Contractor shall remove the signs and reinstall them as needed.

If construction and maintenance sign installation is not completed as specified above or as requested by the Engineer or the Village, liquidated damages in the amount of \$500.00 per day will be assessed. This work shall be considered incidental to the contract.

#### **DEBRIS REMOVAL**

Materials resulting from the removal of asphalt surfaces, pavement patching, etc. shall be removed at the end of each day to an approved site. In the judgment of the Village, should it be necessary to remove such materials, the Village will have the material removed and the Contractor shall have the dollar amount reduced from the next pay estimate.

#### **STREET SWEEPING & PREPARATION**

The Contractor shall be responsible for sweeping and cleaning streets of any debris and material that has accumulated as a result of the construction activity. A mechanical sweeper, mechanically driven air and handwork with shovel and broom shall be utilized to provide a clean street for the motoring public. If street sweeping is not completed as requested by the Engineer or the Village, liquidated damages in the amount of \$500.00 per day will be assessed. This work shall be considered incidental to the contract.

#### **PROTECTION AND RESTORATION OF PROPERTY**

The Contractor shall take all necessary precautions for the protection of public and private property. The Contractor is responsible for the damage or destruction of property resulting from neglect, misconduct, or omission in his/her manner of method of execution or non-execution of the work or caused by defective work, or the use of unsatisfactory materials or equipment, and such responsibility shall not be released until the work has been completed and accepted and the requirements of these specifications complied with.

Whenever public or private property is so damaged or destroyed, the Contractor shall, at his/her expense, restore such property to a condition equal to that which existed prior to such damage or injury by repairing, rebuilding, or replacing it as may be directed, or he/she shall otherwise make good such damage or destruction in an acceptable manner. If he/she fails to do so, the Village will withhold any payouts toward completed work until arrangements are made to correct any damage as described above.

#### **CLEAN CONSTRUCTION AND DEMOLITION DEBRIS**

In addition to the requirements of Section 107.01 of the Standard Specifications, the Contractor shall be responsible for the proper removal and disposal of excavated materials from the project site. The Contractor will meet all requirements set forth by the IEPA and Public Act 96-1416 for Clean Construction and Demolition Debris which may include, but not limited to, field and laboratory analyses, certification from a licensed Professional Engineer, dumping fees and documentation. This work shall not be paid for separately, but will be included in the cost of the contract. No additional compensation will be allowed.

#### **DUST CONTROL WATERING**

This work shall consist of the exclusive control of dust resulting from construction operations and is not intended for use in the compaction of earth embankments, as specified under Article 107.36 of the Standard Specifications. Dust shall be controlled by the uniform application of sprinkled water and shall be applied only when directed by the Engineer, in a manner meeting his approval. All equipment used for this work shall meet the Engineer's approval and shall be equipped with adequate measuring devices for metering the exact amount of water discharged. This work shall include furnishing all labor, water and equipment for controlling dust as herein specified.

This work will not be paid for separately, but will be included in the unit bid prices for various items of work included in the contract.

**PROJECT SCHEDULE OF QUANTITIES  
VILLAGE OF OSWEGO  
2019 STREET RESURFACING**

ROADWAY NAME		Prairieview Drive	Seton Creek Drive	Wollmington Drive	Pearces Ford	Forest Avenue	Main Street	Douglas Street	Judson Street	Mill Road	TOTALS
ROADWAY LIMITS		Forest Ave - Morgan Valley Dr	Wollmington Dr - Gloria Ln	Old Post Rd - Seton Creek Dr	Waubonsie Cir - US 34	Prairieview Dr - IL 171			IL 71 - Hunt Club Dr	Stonehill Rd - US 30	
LENGTH (FOOT)		5,730	3,170	990	2,120	90	-	-	-	-	12,100
WIDTH (FOOT)		28	28	28	28	28	-	-	-	-	VAR
EXTRA AREA (SQ YD)		50	1,000	25	150	25	-	-	-	-	1,250
AREA (SQ YD)		17,880	10,870	3,110	6,750	310	-	-	-	-	38,920
BITUMINOUS MATERIALS (TACK COAT)	POUND	12,070	7,340	2,100	4,560	0	0	0	0	0	26,070
POLYMERIZED LEVELING BINDER (M.M.), IL-4.75, N50	TON	1,060	645	185	400	0	0	0	0	0	2,290
HOT-MIX ASPHALT SURFACE COURSE, MIX "D", N50	TON	2,120	1,290	370	800	0	0	0	0	0	4,580
HOT-MIX ASPHALT SURFACE REMOVAL, 2 3/4"	SQ YD	17,880	10,870	3,110	6,750	0	0	0	0	0	38,610
HOT-MIX ASPHALT SURFACE REMOVAL, BUTT JOINT	SQ YD	45	66	15	35	0	0	0	0	0	161
PORTLAND CEMENT CONCRETE SIDEWALK REMOVAL AND REPLACEMENT, 5 INCH	SQ FT	3,720	640	320	1,080	0	0	0	0	0	5,760
DETECTABLE WARNINGS	SQ FT	930	160	80	270	0	0	0	0	0	1,440
CLASS D PATCHES, 4 INCH	SQ YD	90	55	16	34	0	0	0	0	0	195
HOT-MIX ASPHALT SURFACE REMOVAL AND REPLACEMENT	SQ YD	0	0	0	0	75	670	540	200	300	1,785
COMBINATION CONCRETE CURB & GUTTER REMOVAL AND REPLACEMENT	FOOT	573	317	99	212	0	0	0	0	0	1,201
DRAINAGE AND UTILITY STRUCTURES TO BE ADJUSTED	EACH	20	10	5	5	0	0	0	0	0	40
SEEDING (COMPLETE)	SQ YD	561	133	57	170	0	0	0	0	0	921
THERMOPLASTIC PAVEMENT MARKING, LINE 4"	FOOT	0	0	0	0	100	0	0	0	0	100
THERMOPLASTIC PAVEMENT MARKING, LINE 6"	FOOT	0	0	0	150	0	0	0	0	0	150
THERMOPLASTIC PAVEMENT MARKING, LINE 12"	FOOT	0	0	0	144	0	0	0	0	0	144
TRAFFIC CONTROL AND PROTECTION	L SUM	0	0	0	0	0	0	0	0	0	1

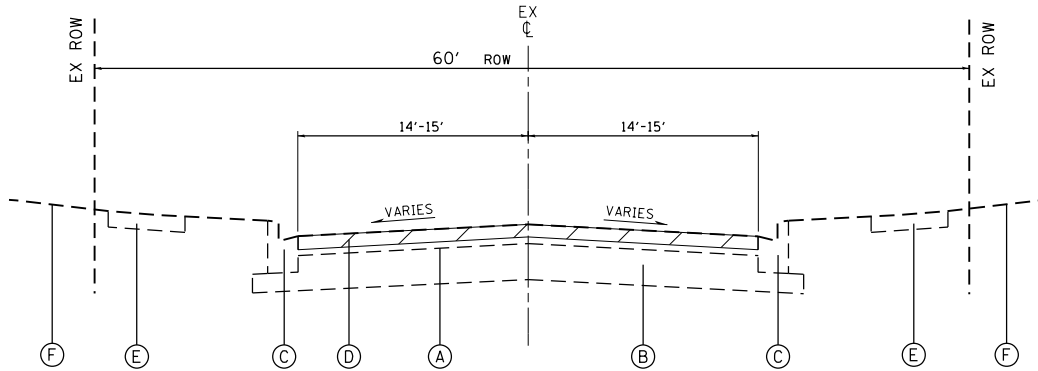

**EXISTING TYPICAL SECTION**

PRAIRIEVIEW DRIVE, SETON CREEK DRIVE  
WOLLMINGTON DRIVE, PEARCES FORD

**NOTE:**

CONTRACTOR SHALL MILL BEFORE PATCHING.

PATCHING LOCATIONS WILL BE DETERMINED BY THE ENGINEER.

RESURFACING TO FINISH 1/4" ABOVE GUTTER FLAG

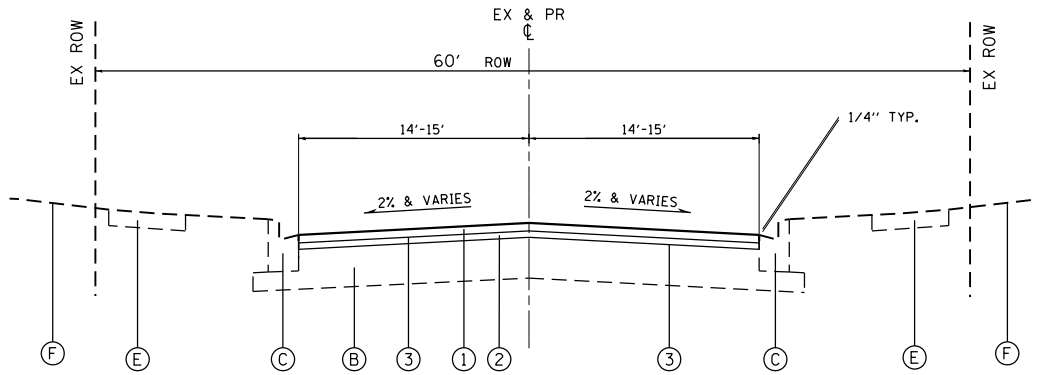

**PROPOSED TYPICAL SECTION**

PRAIRIEVIEW DRIVE, SETON CREEK DRIVE  
WOLLMINGTON DRIVE, PEARCES FORD

**EXISTING LEGEND**

- (A) EXISTING HOT-MIX ASPHALT PAVEMENT, 4"±
- (B) EXISTING AGGREGATE BASE COURSE; 12"±
- (C) EXISTING COMBINATION CONCRETE CURB AND GUTTER (SPOT REMOVAL AND REPLACEMENT AS DIRECTED BY ENGINEER)
- (D) HOT-MIX ASPHALT SURFACE REMOVAL, 2-3/4"
- (E) EXISTING SIDEWALK
- (F) EXISTING GROUND

**PROPOSED LEGEND**

- (1) HOT-MIX ASPHALT SURFACE COURSE, MIX "D", N50; 2"
- (2) POLYMERIZED LEVELING BINDER (M.M.), IL-4.75, N50; 1"
- (3) BITUMINOUS MATERIALS (TACK COAT)

**HOT-MIX ASPHALT MIXTURE REQUIREMENTS**

MIXTURE TYPE	AIR VOIDS
<b>RESURFACING</b>	
HOT-MIX ASPHALT SURFACE COURSE, MIX D, N50; (IL-9.5mm)	3.5% @ 50 GYR.
POLYMERIZED LEVELING BINDER (M.M.), IL-4.75, N50	3.5% @ 50 GYR.
<b>DRIVEWAYS</b>	
HOT-MIX ASPHALT SURFACE COURSE, MIX D, N50; (IL-9.5mm)	3.5% @ 50 GYR.
<b>PATCHING</b>	
CLASS D PATCH (HMA BINDER IL-19mm)	4.0% @ 70 GYR.

THE UNIT WEIGHT TO CALCULATE ALL HMA SURFACE MIXTURE QUANTITIES IS 112 LBS/SQ YD/IN

FOR USE OF RECYCLED MATERIALS SEE BDE SPECIAL PROVISION.

REVISIONS		
#	DATE:	BY:
1.		
2.		
3.		
4.		
5.		
6.		
7.		
8.		
9.		
10.		



**VILLAGE OF OSWEGO  
2019 STREET RESURFACING**

SHEET ORIENTATION

DATE:	04/19/19
HORIZ. SCALE:	N.T.S.
DWN. BY:	DSN. BY: CHK: 147
	BDH
SECTION NO.	19-00000-00-GM
SHEET NO.	1

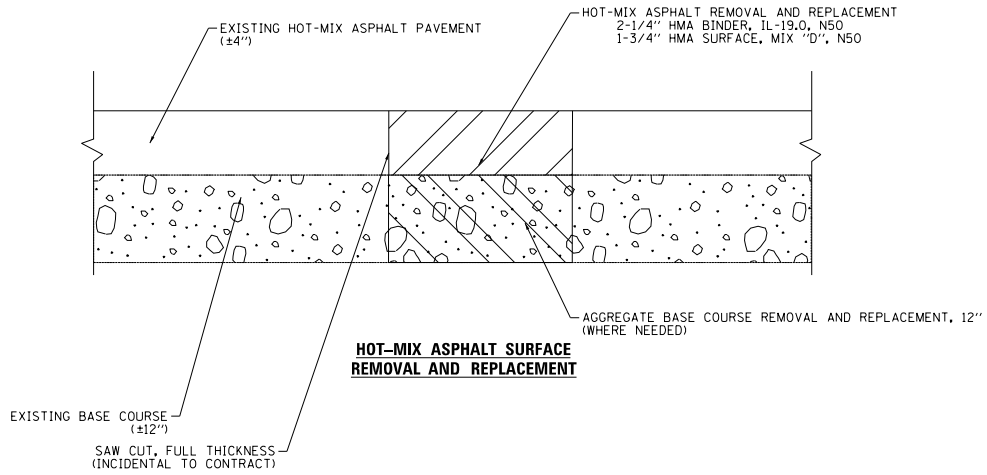

REVISIONS		
#	DATE:	BY:
1.		
2.		
3.		
4.		
5.		
6.		
7.		
8.		
9.		
10.		



HRGreen.com  
Illinois Professional Design Firm  
# 184-001322

**VILLAGE OF OSWEGO  
2019 STREET RESURFACING**

SHEET ORIENTATION

DATE: 04/19/19		
HORIZ. SCALE: N.T.S.		
DWN. BY:	DSN. BY:	CHK# 148
	BDH	
SECTION NO. 19-00000-00-GM		
SHEET NO. <b>2</b>		

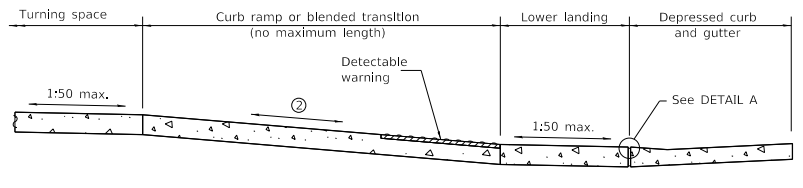
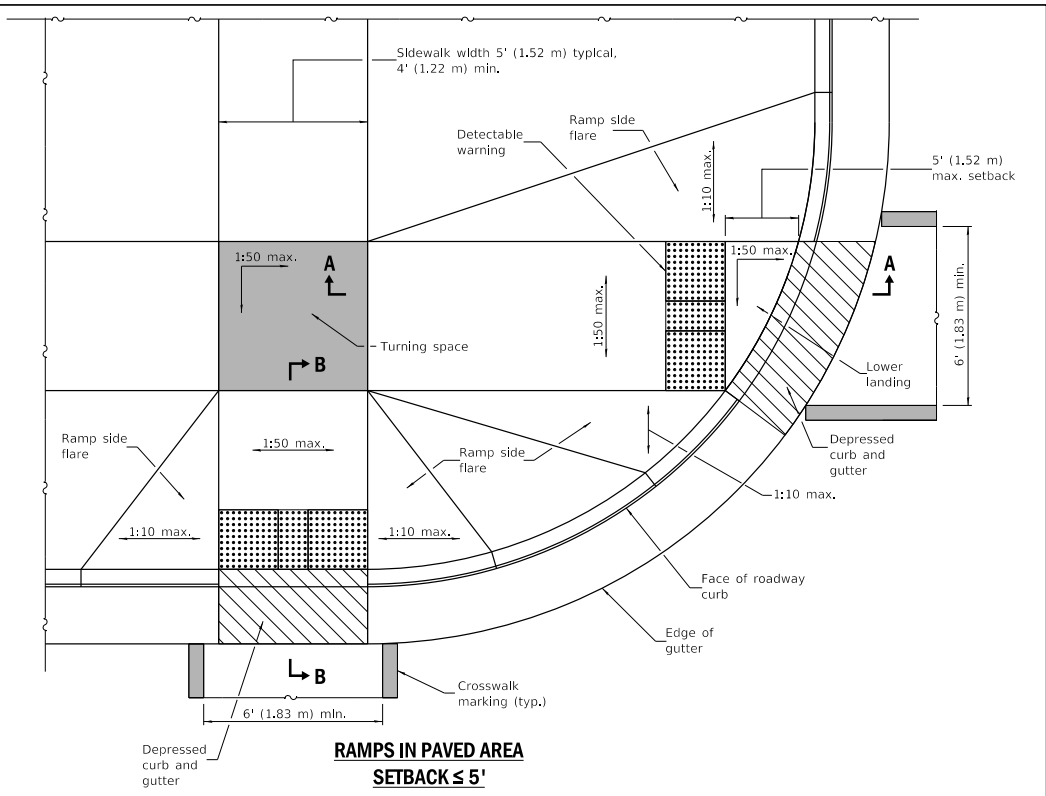
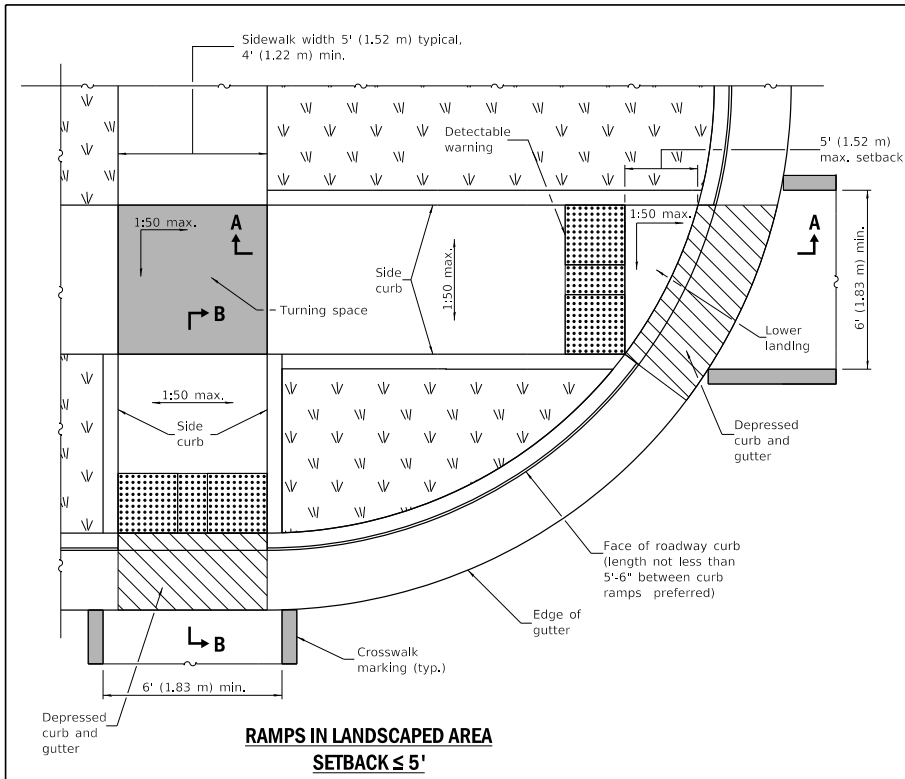

② The running slope of a curb ramp shall be 1:20 min. and 1:12 max. The running slope of a blended transition shall be 1:20 max.

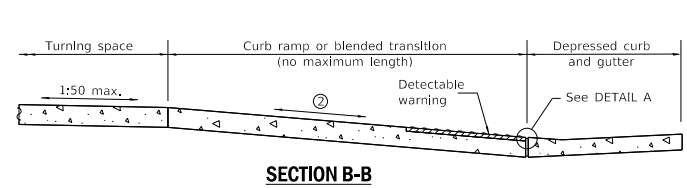

② The running slope of a curb ramp shall be 1:20 min. and 1:12 max. The running slope of a blended transition shall be 1:20 max.

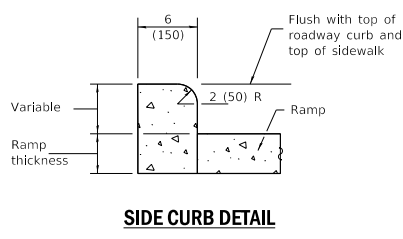
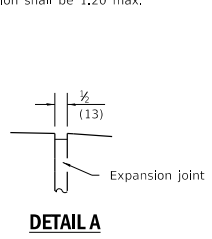

Illinois Department of Transportation

PASSED January 1, 2019

ENGINEER OF POLICY AND PROCEDURES

APPROVED January 1, 2019

ENGINEER OF DESIGN AND ENVIRONMENT

ISSUED 1-1-17

See Sheet 2 for GENERAL NOTES.

DATE	REVISIONS
1-1-19	Removed "15-foot rule", added "Blended transitions" and placement tolerances for detectable warnings.
1-1-18	Omitted diagonal slope at turning spaces and lower landings.

**PERPENDICULAR CURB RAMPS  
FOR SIDEWALKS**

(Sheet 1 of 2)

**STANDARD 424001-11 149**

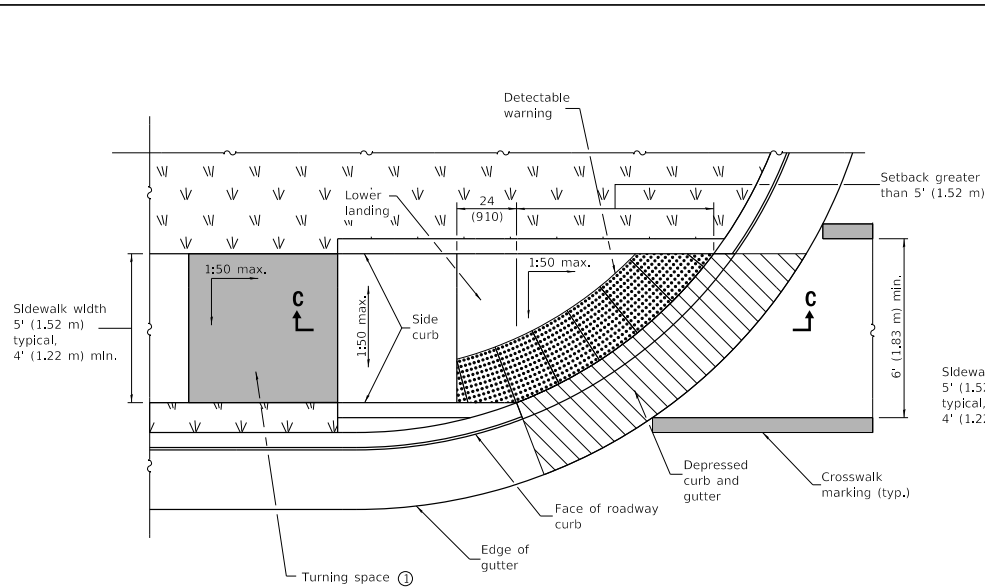

**RAMP IN LANDSCAPED AREA  
SETBACK > 5'**

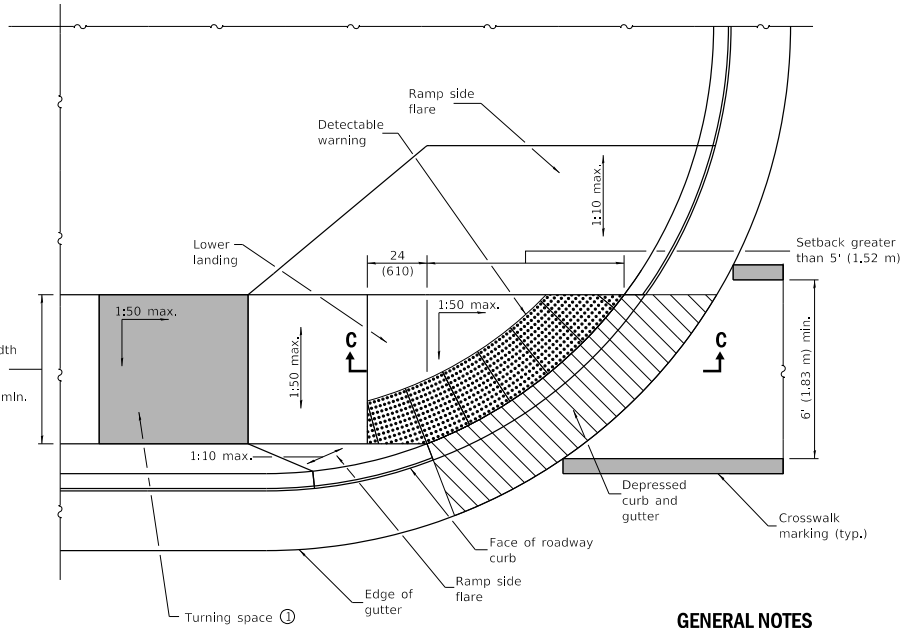

**RAMP IN PAVED AREA  
SETBACK > 5'**

**GENERAL NOTES**

All slope ratios are expressed as units of vertical displacement to units of horizontal displacement (V:H).

Where the turning space is constrained on a side opposite a ramp, the minimum length of the turning space in the direction of the ramp-run shall be 5' (1.52 m).

Where 1:50 maximum slope is shown, 1:64 is preferred.

Detectable warnings are shown in their ideal locations but the following placement tolerances are allowed.

**Side Border** - Detectable warnings should extend the full width of the walking surface (excluding flared sides) but a border along each side up to 2 in. (50 mm) in width is allowed.

**Curb Set-Back** - Detectable warnings located at the back of curb should closely align with the curb but a gap up to 6 in. (150 mm) behind the curb is allowed.

See Standard 606001 for details of depressed curb adjacent to curb ramp.

All dimensions are in inches (millimeters) unless otherwise shown.

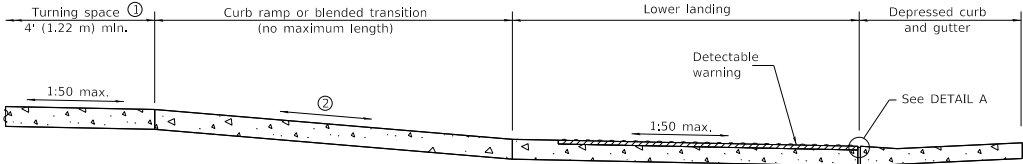

**SECTION C-C**

- ① This turning space not required for blended transitions.
- ② The running slope of a curb ramp shall be 1:20 min, and 1:12 max. The running slope of a blended transition shall be 1:20 max.

Illinois Department of Transportation	
PASSED <i>M. B. ...</i> January 1, 2019 ENGINEER OF POLICY AND PROCEDURES	ISSUED 1-1-17
APPROVED <i>S. ...</i> January 1, 2019 ENGINEER OF DESIGN AND ENVIRONMENT	

<b>PERPENDICULAR CURB RAMPS FOR SIDEWALKS</b> (Sheet 2 of 2)	
<b>STANDARD 424001-11</b>	<b>150</b>

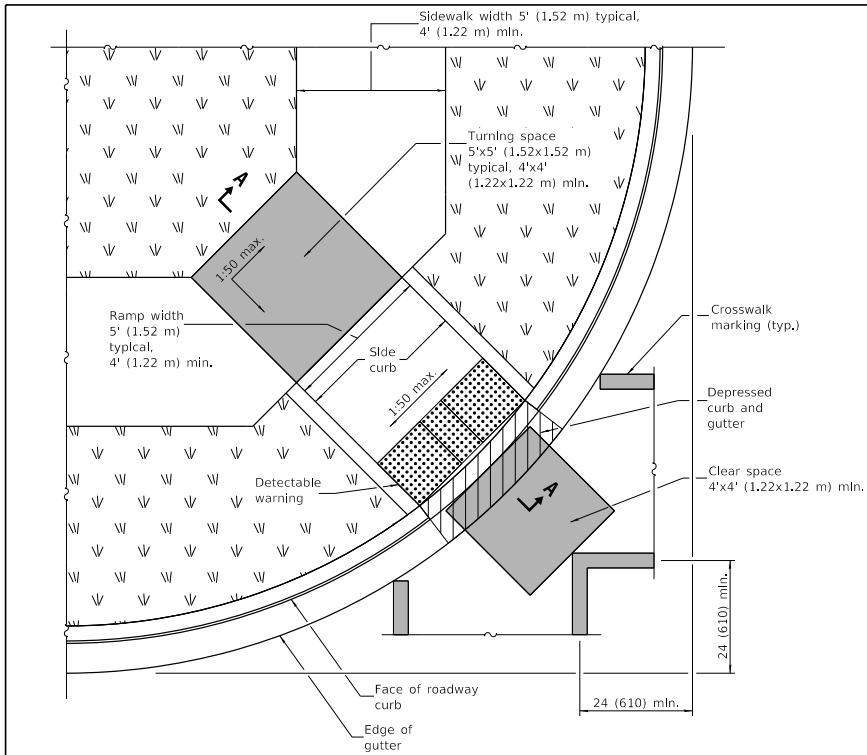

**RAMP IN LANDSCAPED AREA**

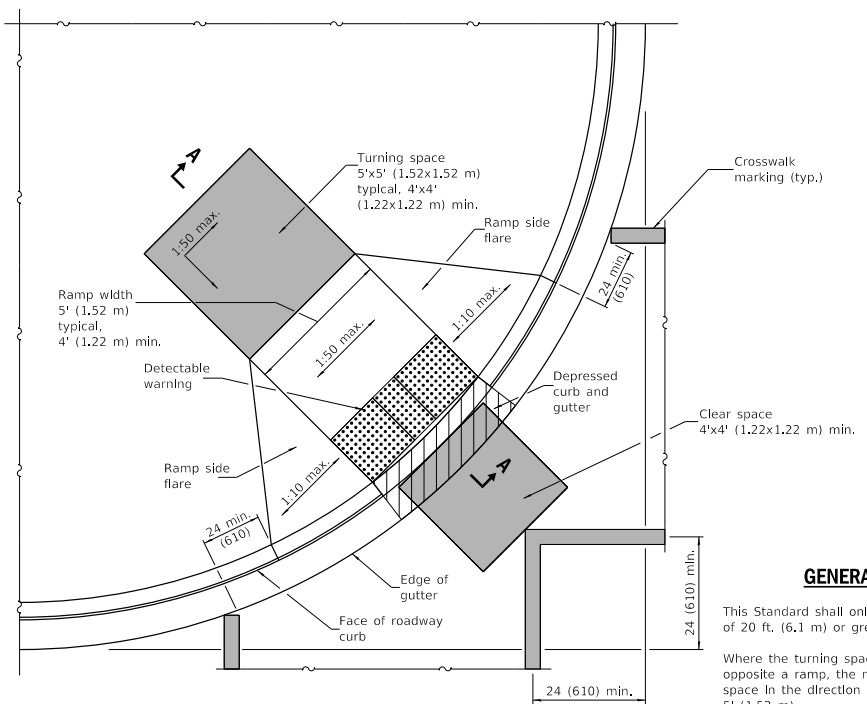

**RAMP IN PAVED AREA**

**GENERAL NOTES**

This Standard shall only be used for curb radii of 20 ft. (6.1 m) or greater.

Where the turning space is constrained on a side opposite a ramp, the minimum length of the turning space in the direction of the ramp-run shall be 5' (1.52 m).

Where 1:50 maximum slope is shown, 1:64 is preferred.

Detectable warnings are shown in their ideal locations but the following placement tolerances are allowed.

**Side Border** - Detectable warnings should extend the full width of the walking surface (excluding flared sides) but a border along each side up to 2 in. (50 mm) in width is allowed.

**Curb Set-Back** - Detectable warnings located at the back of curb should closely align with the curb but a gap up to 6 in. (150 mm) behind the curb is allowed.

All slope ratios are expressed as units of vertical displacement to units of horizontal displacement (V:H).

See Standard 606001 for details of depressed curb adjacent to curb ramp.

All dimensions are in inches (millimeters) unless otherwise shown.

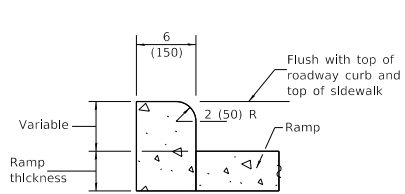

**SIDE CURB DETAIL**

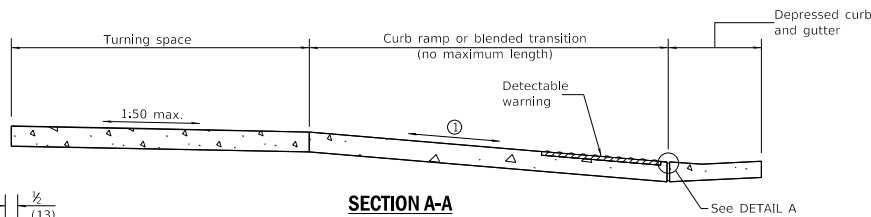

**SECTION A-A**

① The running slope of a curb ramp shall be 1:20 min. and 1:12 max. The running slope of a blended transition shall be 1:20 max.

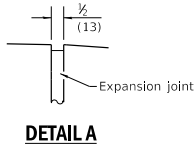

**DETAIL A**

DATE	REVISIONS
1-1-19	Removed "15-foot rule", added "blended transitions" and placement tolerances for detectable warnings.
1-1-18	Omitted diagonal slope at turning spaces.

**DIAGONAL CURB RAMPS FOR SIDEWALKS**

**STANDARD 424006-04 151**

Illinois Department of Transportation

PASSED January 1, 2019  
*Michael B. ...*  
 ENGINEER OF POLICY AND PROCEDURES

APPROVED January 1, 2019  
*John E. ...*  
 ENGINEER OF DESIGN AND ENVIRONMENT

ISSUED 1-1-12

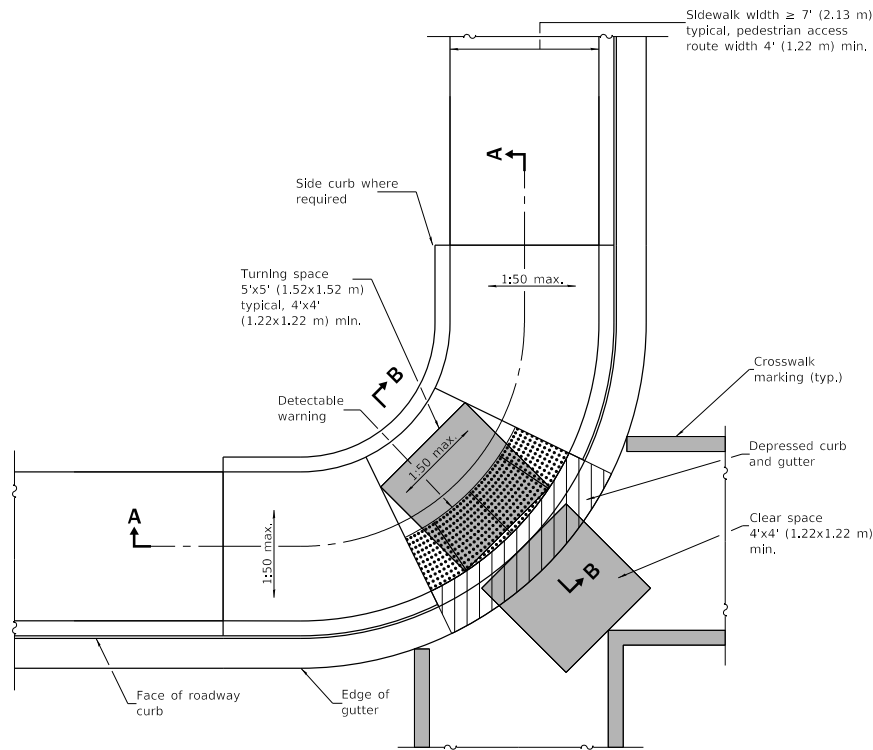

**CORNER PARALLEL CURB RAMP**

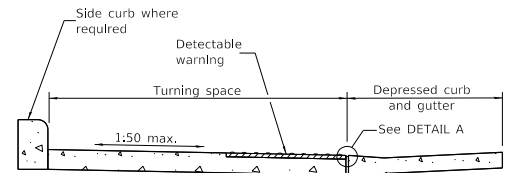

**SECTION B-B**

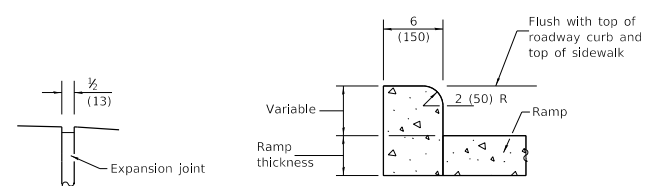

**DETAIL A**

**SIDE CURB DETAIL**

**GENERAL NOTES**

All slope ratios are expressed as units of vertical displacement to units of horizontal displacement (V:H).

Where the turning space is constrained on a side opposite a ramp, the minimum length of the turning space in the direction of the ramp-run shall be 5' (1.52 m).

Where 1:50 maximum slope is shown, 1:64 is preferred.

Detectable warnings are shown in their ideal locations but the following placement tolerances are allowed.

**Side Border** - Detectable warnings should extend the full width of the walking surface (excluding flared slides) but a border along each side up to 2 in. (50 mm) in width is allowed.

**Curb Set-Back** - Detectable warnings located at the back of curb should closely align with the curb but a gap up to 6 in. (150 mm) behind the curb is allowed.

See Standard 606001 for details of depressed curb adjacent to curb ramp.

All dimensions are in Inches (millimeters) unless otherwise shown.

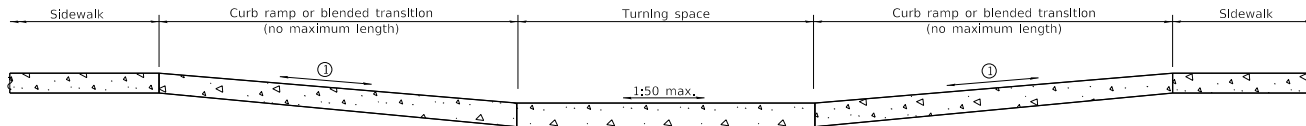

**SECTION A-A**

① The running slope of a curb ramp shall be 1:20 min. and 1:12 max. The running slope of a blended transition shall be 1:20 max.

DATE	REVISIONS
1-1-19	Removed upper landing, added blended transition and detectable warning tolerances.
1-1-17	Revised sidewalk width to include 24 (610) buffer behind curb.

**CORNER PARALLEL CURB RAMPS FOR SIDEWALKS**

**STANDARD 424011-04 152**

Illinois Department of Transportation

PASSED *Michael B. ...* January 1, 2019  
 ENGINEER OF POLICY AND PROCEDURES

APPROVED *J. ...* January 1, 2019  
 ENGINEER OF DESIGN AND ENVIRONMENT

ISSUED 1-1-17



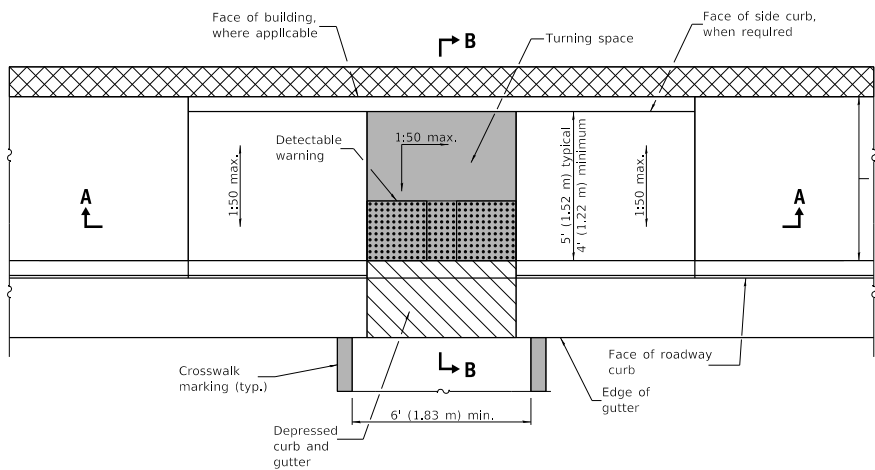

**PARALLEL MID-BLOCK CURB RAMP**

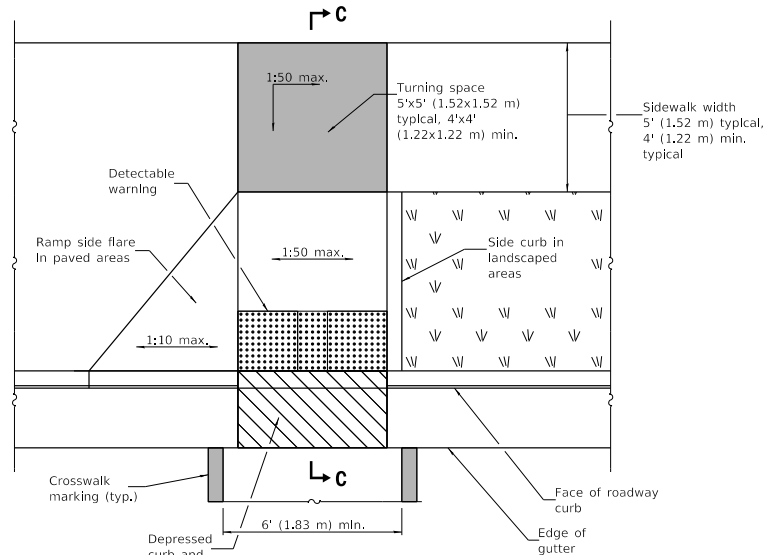

**PERPENDICULAR MID-BLOCK CURB RAMP**

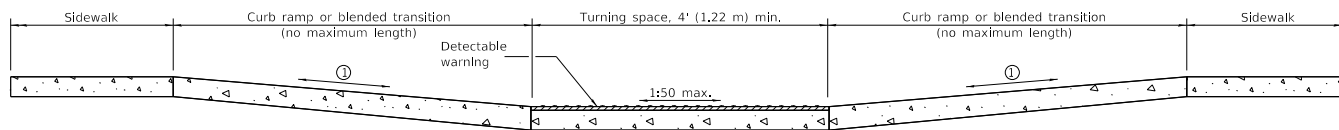

**SECTION A-A**

① The running slope of a curb ramp shall be 1:20 min. and 1:12 max. The running slope of a blended transition shall be 1:20 max.

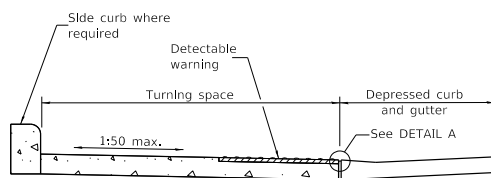

**SECTION B-B**

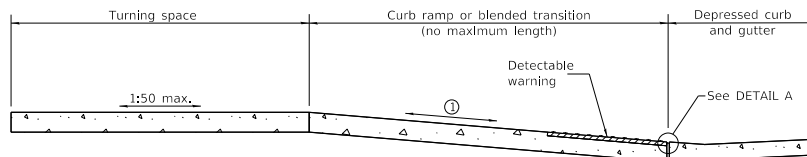

**SECTION C-C**

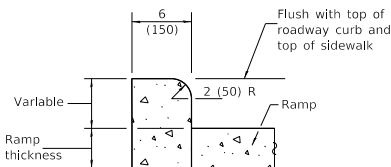

**SIDE CURB DETAIL**

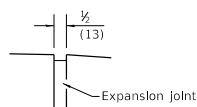

**DETAIL A**

**GENERAL NOTES**

All slope ratios are expressed as units of vertical displacement to units of horizontal displacement (V:H).

Where the turning space is constrained on a side opposite a ramp, the minimum length of the turning space in the direction of the ramp-run shall be 5' (1.52 m).

Where 1:50 maximum slope is shown, 1:64 is preferred.

Detectable warnings are shown in their ideal locations but the following placement tolerances are allowed.

Side Border - Detectable warnings should extend the full width of the walking surface (excluding flared slides) but a border along each side up to 2 in. (50 mm) in. width is allowed.

Curb Set-Back - Detectable warnings located at the back of curb should closely align with the curb but a gap up to 6 in. (150 mm) behind the curb is allowed.

See Standard 606001 for details of depressed curb adjacent to curb ramp.

All dimensions are in inches (millimeters) unless otherwise shown.

DATE	REVISIONS
1-1-19	Removed upper landing, added blended transitions and detectable warning tolerances.
1-1-18	Omitted diagonal slope at turning spaces and upper landings.

**MID-BLOCK CURB RAMPS FOR SIDEWALKS**

STANDARD 424016-05

153

Illinois Department of Transportation

PASSED *M. B. D.* January 1, 2019  
ENGINEER OF POLICY AND PROCEDURES

APPROVED *S. J. C.* January 1, 2019  
ENGINEER OF DESIGN AND ENVIRONMENT

ISSUED 1-1-12

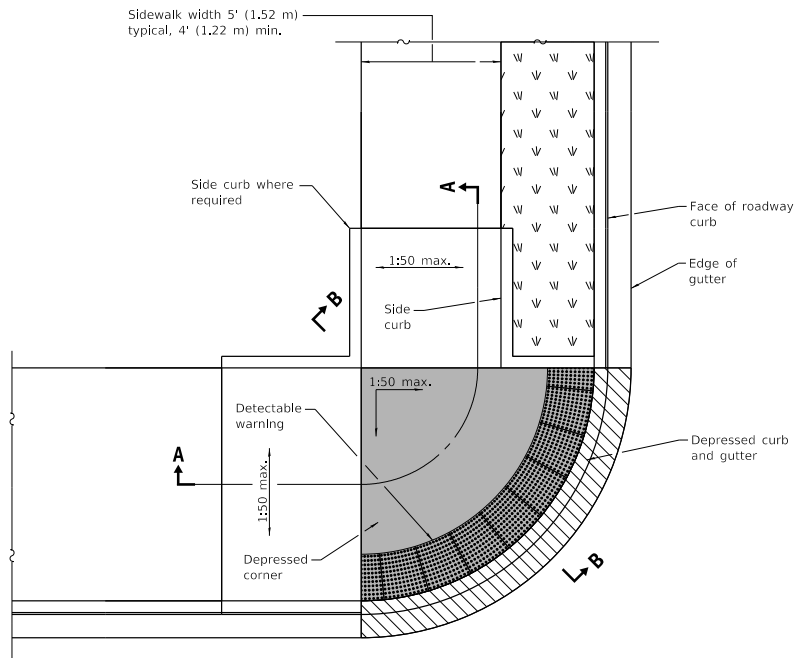

**DEPRESSED CORNER**

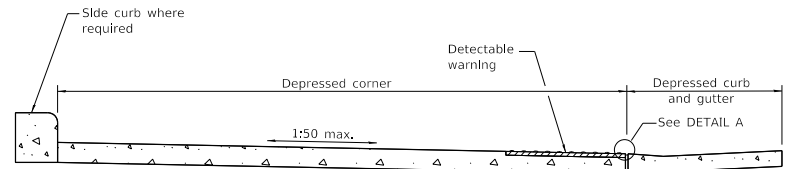

**SECTION B-B**

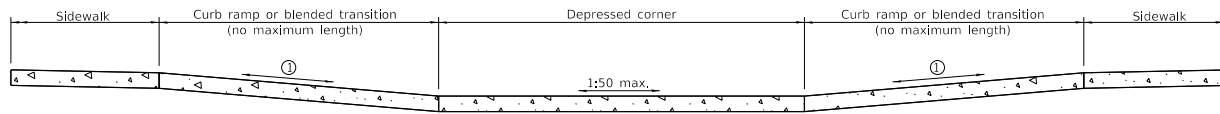

① The running slope of a curb ramp shall be 1:20 min, and 1:12 max. The running slope of a blended transition shall be 1:20 max.

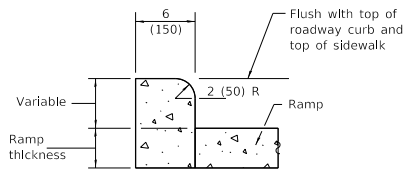
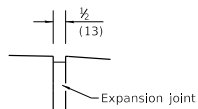

**GENERAL NOTES**

This standard shall only be used for curb radii of 6 ft. (1.83 m) or greater.

All slope ratios are expressed as units of vertical displacement to units of horizontal displacement (V:H).

Where 1:50 maximum slope is shown, 1:64 is preferred.

Detectable warnings are shown in their ideal tolerances but the following placement tolerances are allowed.

**Side Border** - Detectable warnings should extend the full width of the walking surface (excluding flared sides) but a border along each side up to 2 in. (50 mm) in, width is allowed.

**Curb Set-Back** - Detectable warnings located at the back of curb should closely align with the curb but a gap up to 6 in. (150 mm) behind the curb is allowed.

See Standard 606001 for details of depressed curb adjacent to curb ramp.

All dimensions are in inches (millimeters) unless otherwise shown.

DATE	REVISIONS
1-1-19	Removed upper landings, added blended transition and detectable warning tolerances.
1-1-18	Omitted diagonal slope at turning spaces and upper landings.

**DEPRESSED CORNER FOR SIDEWALKS**

STANDARD 424021-05

154

Illinois Department of Transportation

PASSED January 1, 2019  
*Michael B. ...*  
 ENGINEER OF POLICY AND PROCEDURES

APPROVED January 1, 2019  
*John E. ...*  
 ENGINEER OF DESIGN AND ENVIRONMENT

ISSUED 1-1-12

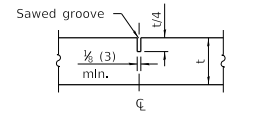
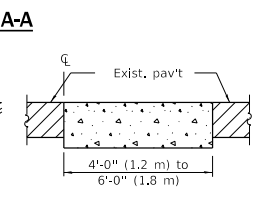
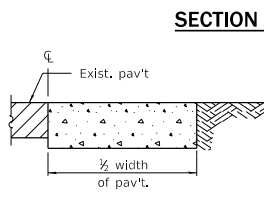
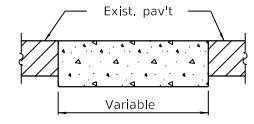
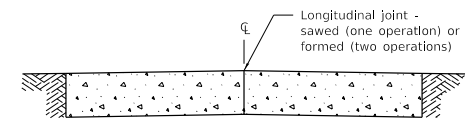
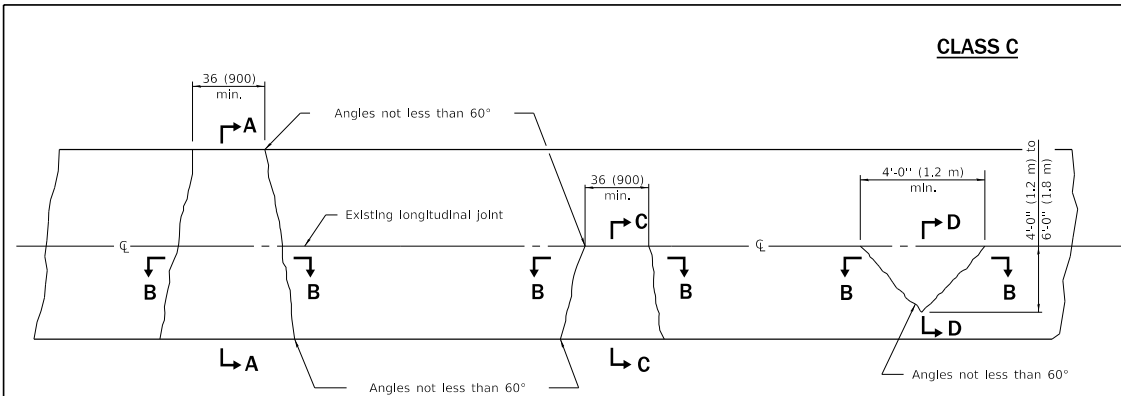

**Note:**  
Longitudinal joints shall be as detailed on Standard 420001, except tie bars are not required for patches 20'-0" (6.0 m) or less in length.

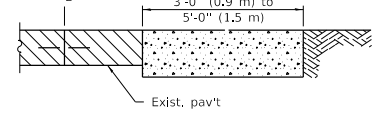
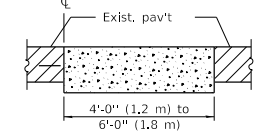
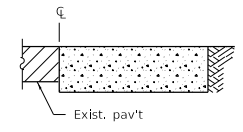
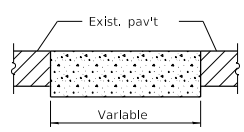
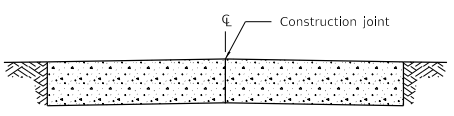
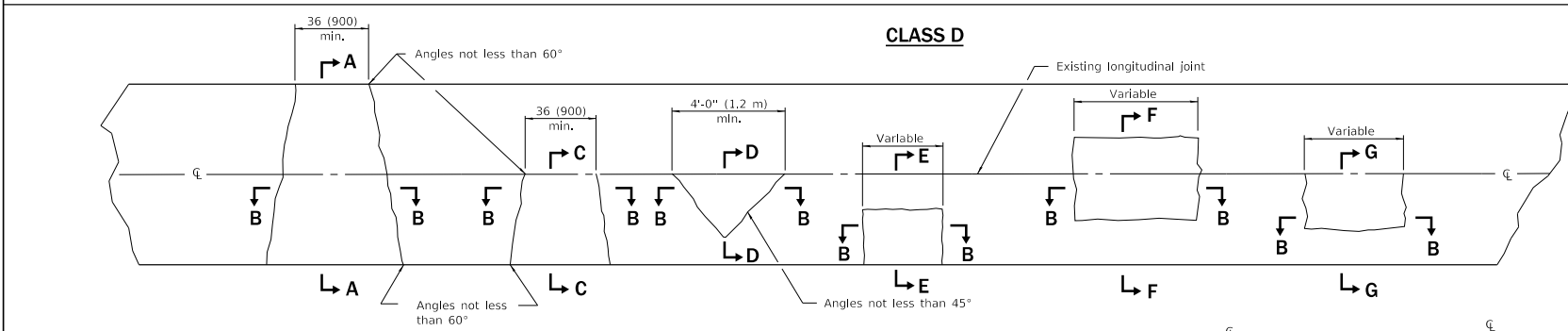

**SECTION A-A**  
(Built in two operations)

**SECTION B-B**

**SECTION C-C**

**SECTION D-D**

**SECTION E-E**

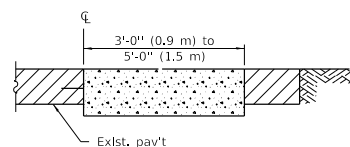
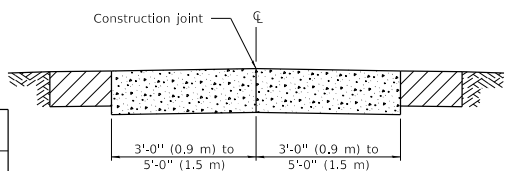

**SECTION F-F**  
(Built In two operations)

**SECTION G-G**

**GENERAL NOTES**  
Existing tie bars shall be either cut or removed. Marginal bars shall be cut.

All dimensions are in inches (millimeters) unless otherwise shown.

Illinois Department of Transportation

PASSED January 1, 2008

ENGINEER OF POLICY AND PROCEDURES

APPROVED January 1, 2008

ENGINEER OF DESIGN AND ENVIRONMENT

ISSUED 1-1-07

DATE	REVISIONS
1-1-08	Switched units to English (metric).
1-1-07	Revised Note for Class C patches.

## CLASS C and D PATCHES

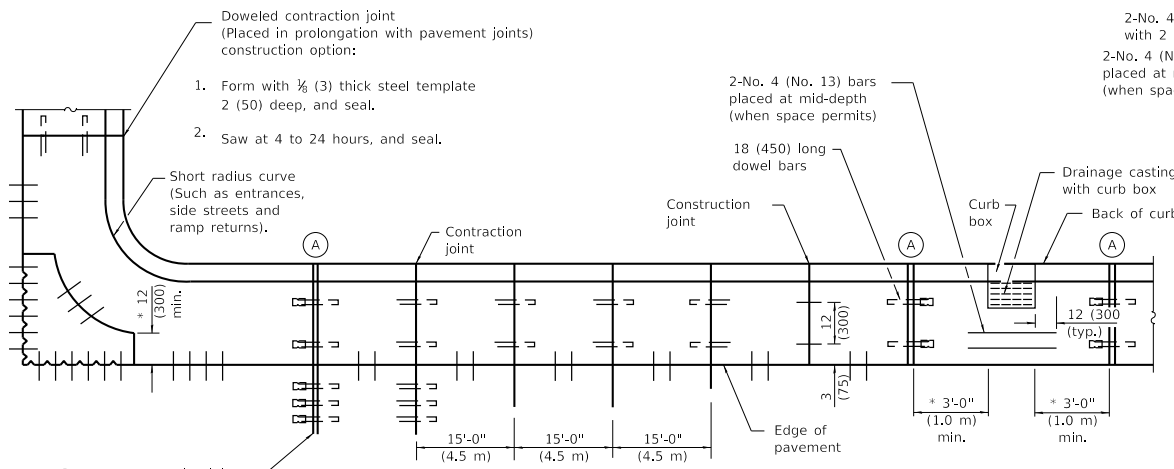

**PLAN**  
**ADJACENT TO PCC PAVEMENT OR PCC BASE COURSE**

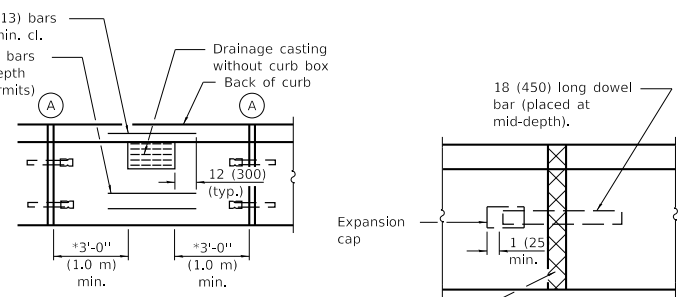

**DETAIL A**  
**EXPANSION JOINT**

\* This dimension shall be adjusted to align with joint on the adjacent pavement

Full depth & width 1 (25) - thick (min.) preformed expansion joint filter.

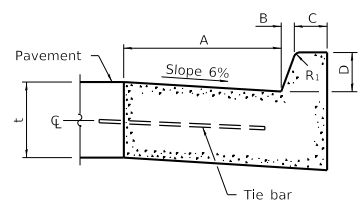

**BARRIER CURB**

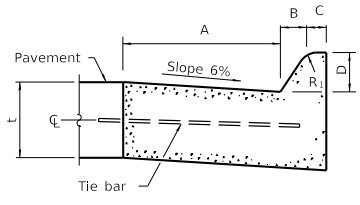

**MOUNTABLE CURB**

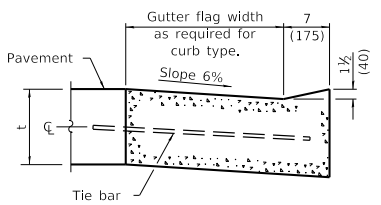

**DEPRESSED CURB (TYPICAL)**

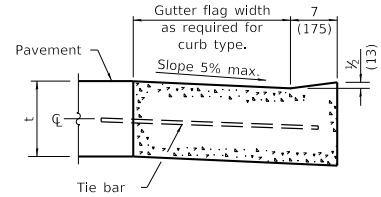

**DEPRESSED CURB ADJACENT TO CURB RAMP ACCESSIBLE TO THE DISABLED**

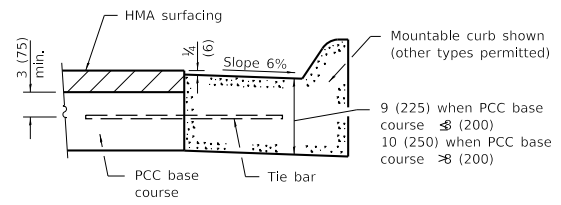

**ADJACENT TO PCC BASE COURSE WITH HMA SURFACING**

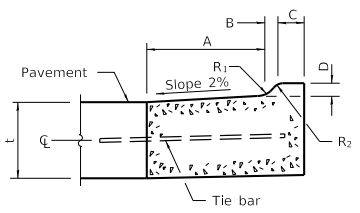

**M-2.06 (M-5.15) and M-2.12 (M-5.30)**

TABLE OF DIMENSIONS BARRIER CURB					
TYPE	A	B	C	D	R <sub>1</sub>
B-6.06 *	6	1	6	6	1
(B-15.15)	(150)	(25)	(150)	(150)	(25)
B-6.12	12	1	6	6	1
(B-15.3)	(300)	(25)	(150)	(150)	(25)
B-6.18	18	1	6	6	1
(B-15.45)	(450)	(25)	(150)	(150)	(25)
B-6.24	24	1	6	6	1
(B-15.60)	(600)	(25)	(150)	(150)	(25)
B-9.12	12	2	5	9	1
(B-22.30)	(300)	(50)	(125)	(225)	(25)
B-9.18	18	2	5	9	1
(B-22.45)	(450)	(50)	(125)	(225)	(25)
B-9.24	24	2	5	9	1
(B-22.60)	(600)	(50)	(125)	(225)	(25)

\* For corner islands only.

TABLE OF DIMENSIONS MOUNTABLE CURB						
TYPE	A	B	C	D	R <sub>1</sub>	R <sub>2</sub>
M-2.06	6	2	4	2	3	2
(M-5.15)	(150)	(50)	(100)	(50)	(75)	(50)
M-2.12	12	2	4	2	3	2
(M-5.30)	(300)	(50)	(100)	(50)	(75)	(50)
M-4.06	6	4	3	4	3	NA
(M-10.15)	(150)	(100)	(75)	(100)	(75)	NA
M-4.12	12	4	3	4	3	NA
(M-10.30)	(300)	(100)	(75)	(100)	(75)	NA
M-4.18	18	4	3	4	3	NA
(M-10.45)	(450)	(100)	(75)	(100)	(75)	NA
M-4.24	24	4	3	4	3	NA
(M-10.60)	(600)	(100)	(75)	(100)	(75)	NA
M-6.06	6	6	2	6	2	NA
(M-15.15)	(150)	(150)	(50)	(150)	(50)	NA
M-6.12	12	6	2	6	2	NA
(M-15.30)	(300)	(150)	(50)	(150)	(50)	NA
M-6.18	18	6	2	6	2	NA
(M-15.45)	(450)	(150)	(50)	(150)	(50)	NA
M-6.24	24	6	2	6	2	NA
(M-15.60)	(600)	(150)	(50)	(150)	(50)	NA

DATE	REVISIONS
1-1-18	Revised General Note for tie bar spacing to 36 (900) cts.
1-1-15	Added B-6.06 (B-15.15) barrier curb and gutter to table (corner islands only).

**CONCRETE CURB TYPE B AND COMBINATION CONCRETE CURB AND GUTTER**

Illinois Department of Transportation

PASSED January 1, 2018

Michael Beard  
ENGINEER OF POLICY AND PROCEDURES

APPROVED January 1, 2018

Maureen M. Bello  
ENGINEER OF DESIGN AND ENVIRONMENT

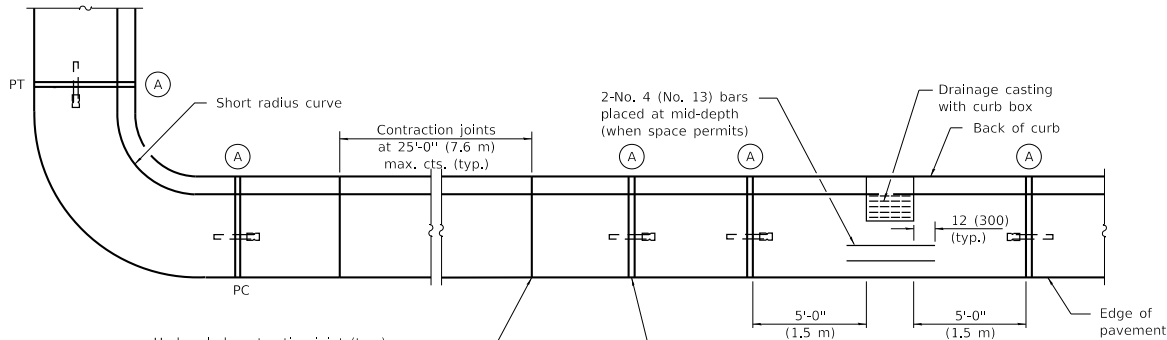

Undoweled contraction joint (typ.) construction options:

1. Form with 3/8" (3) thick steel template 2 (50) deep, and seal.
2. Saw 2 (50) deep at 4 to 24 hours, and seal.
3. Insert 3/4" (20) thick preformed joint filler full depth and width.

Construction joint  
2-No. 4 (No. 13) bars with 2 (50) min. cl.

2-No. 4 (No. 13) bars placed at mid-depth (when space permits)

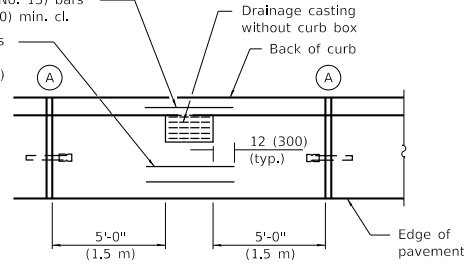

**PLAN**

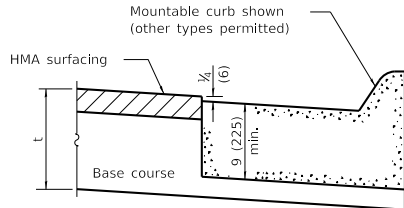

**ON DISTURBED SUBGRADE**

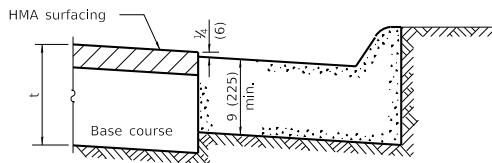

**ON UNDISTURBED SUBGRADE**

**ADJACENT TO FLEXIBLE PAVEMENT**

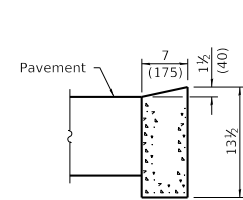

**DEPRESSED CURB**

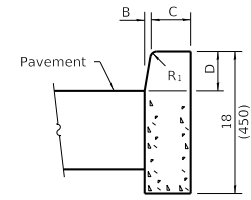

**BARRIER CURB**

**ADJACENT TO FLEXIBLE PAVEMENT**

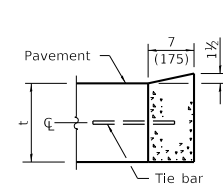

**DEPRESSED CURB**

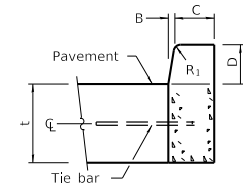

**BARRIER CURB**

**ADJACENT TO PCC PAVEMENT OR PCC BASE COURSE**

**CONCRETE CURB TYPE B**

Illinois Department of Transportation

PASSED January 1, 2018  
*Michael Beard*  
 ENGINEER OF POLICY AND PROCEDURES

APPROVED January 1, 2018  
*Maureen M. Bels*  
 ENGINEER OF DESIGN AND ENVIRONMENT

ISSUED 14-147

**CONCRETE CURB TYPE B  
 AND COMBINATION  
 CONCRETE CURB AND GUTTER**

(Sheet 2 of 2)

STANDARD 606001-07 157

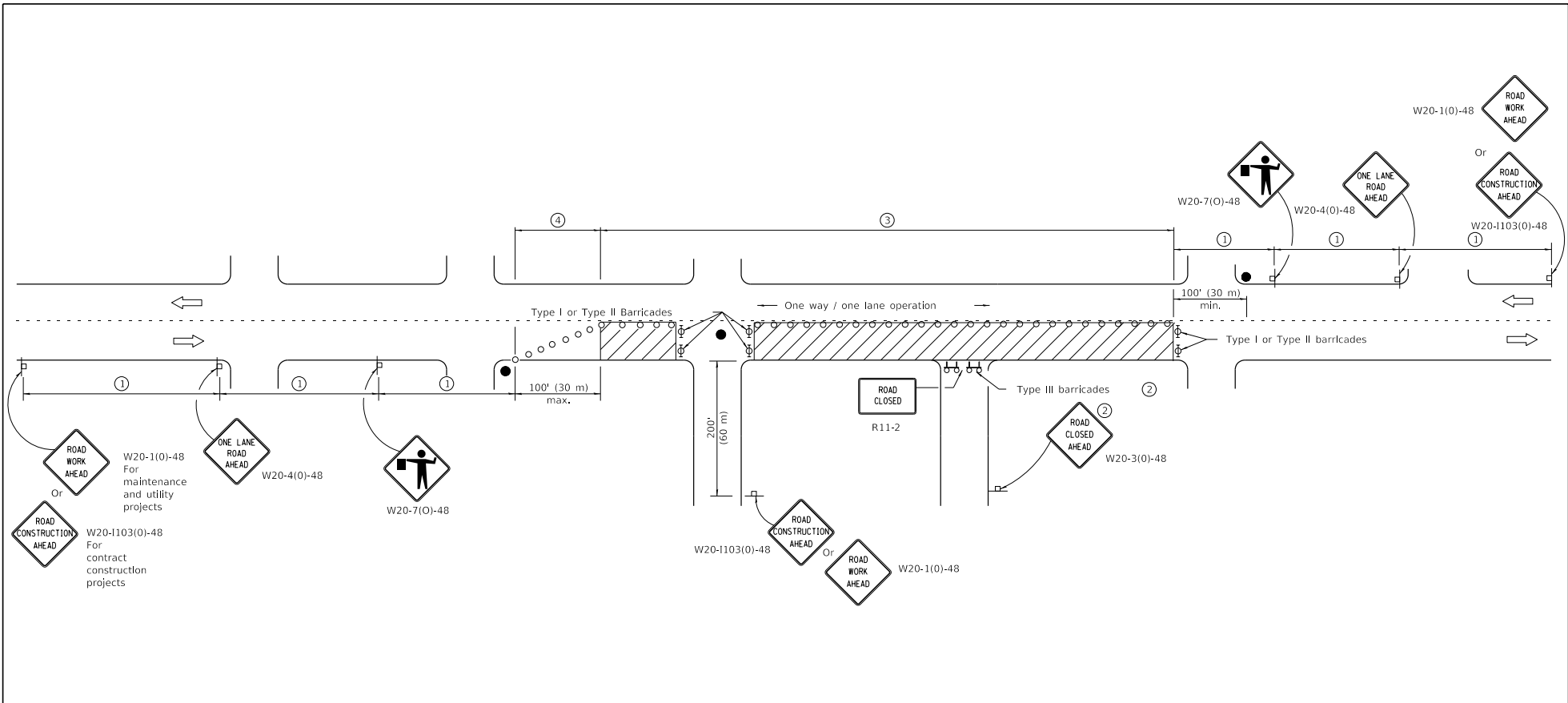

SIGN SPACING	
Posted Speed	Sign Spacing
55	500' (150 m)
50-45	350' (100 m)
<45	200' (60 m)

**SYMBOLS**

- Work area
- Cone, drum or barricade (not required for moving operations)
- Sign on portable or permanent support
- Flagger with traffic control sign
- Barricade or drum with flashing light
- Type III barricade with flashing lights

- ① Refer to SIGN SPACING TABLE for distances.
- ② For approved sideroad closures.
- ③ Cones at 25' (8 m) centers for 250' (75 m). Additional cones may be placed at 50' (15 m) centers. When drums or Type I or Type II barricades are used, the interval between devices may be doubled.
- ④ Cones, drums or barricades at 20' (6 m) centers.

**GENERAL NOTES**

This Standard is used where at any time, day or night, any vehicle, equipment, workers or their activities encroach on the pavement requiring the closure of one traffic lane in an urban area.

All dimensions are in inches (millimeters) unless otherwise shown.

Illinois Department of Transportation

PASSED January 1, 2011  
 ENGINEER OF SAFETY ENGINEERING

APPROVED January 1, 2011  
 ENGINEER OF DESIGN AND ENVIRONMENT

ISSUED 1-1-11

DATE	REVISIONS
1-1-11	Revised flagger sign.
1-1-09	Switched units to English (metric).
	Corrected sign No.'s.

**URBAN LANE CLOSURE,  
2L, 2W, UNDIVIDED**

**STANDARD 701501-06 158**

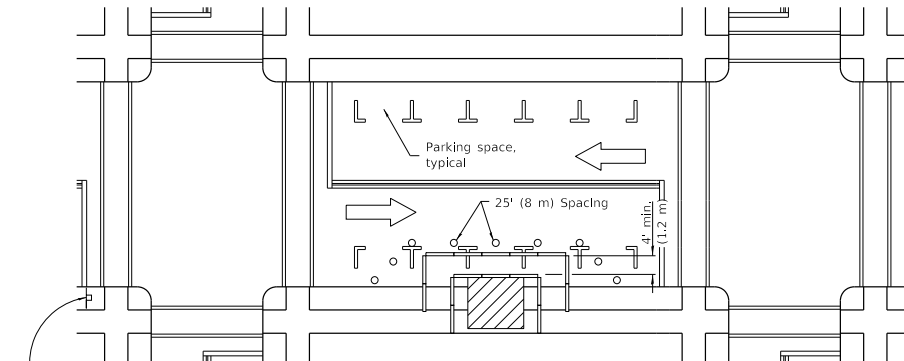

① ROAD CONSTRUCTION AHEAD  
W20-1103(0)-48 for contract construction projects

Or

① ROAD WORK AHEAD  
W20-1(0)-48 for maintenance and utility projects

**SIDEWALK DIVERSION**

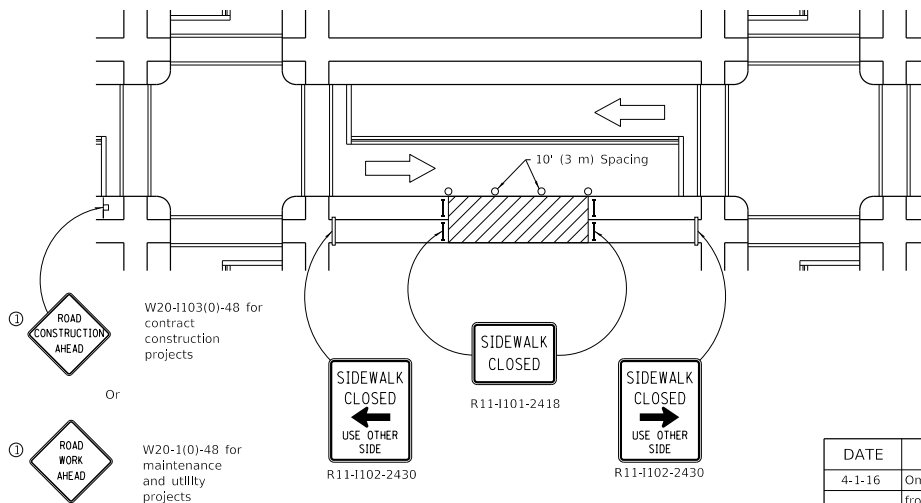

① ROAD CONSTRUCTION AHEAD  
W20-1103(0)-48 for contract construction projects

Or

① ROAD WORK AHEAD  
W20-1(0)-48 for maintenance and utility projects

**SIDEWALK CLOSURE**

- SYMBOLS**
- Work area
  - Sign on portable or permanent support
  - Barricade or drum
  - Cone, drum or barricade
  - Type III barricade
  - Detectable pedestrian channelizing barricade

① Omit whenever duplicated by road work traffic control.

**GENERAL NOTES**

This Standard is used where, at any time, pedestrian traffic must be rerouted due to work being performed.

This Standard must be used in conjunction with other Traffic Control & Protection Standards when roadway traffic is affected.

Temporary facilities shall be detectable and accessible.

The temporary pedestrian facilities shall be provided on the same side of the closed facilities whenever possible.

The SIDEWALK CLOSED / USE OTHER SIDE sign shall be placed at the nearest crosswalk or intersection to each end of the closure. Where the closure occurs at a corner, the signs shall be erected on the corners across the street from the closure. The SIDEWALK CLOSED signs shall be used at the ends of the actual closures.

Type III barricades and R11-2-4830 signs shall be positioned as shown in "ROAD CLOSED TO ALL TRAFFIC" detail on Standard 701901.

All dimensions are in inches (millimeters) unless otherwise shown.

DATE	REVISIONS
4-1-16	Omitted orange safety fence from standard as this is covered in the std. spec.
1-1-12	Added SIDEWALK DIVERSION. Modified appearance of plan views. Renamed Std.

**SIDEWALK, CORNER OR CROSSWALK CLOSURE**

(Sheet 1 of 2)

STANDARD 701801-06

159

Illinois Department of Transportation

PASSED *[Signature]* April 1, 2016  
ENGINEER OF SAFETY ENGINEERING

APPROVED *[Signature]* April 1, 2016  
ENGINEER OF DESIGN AND ENVIRONMENT

ISSUED 1-1-17

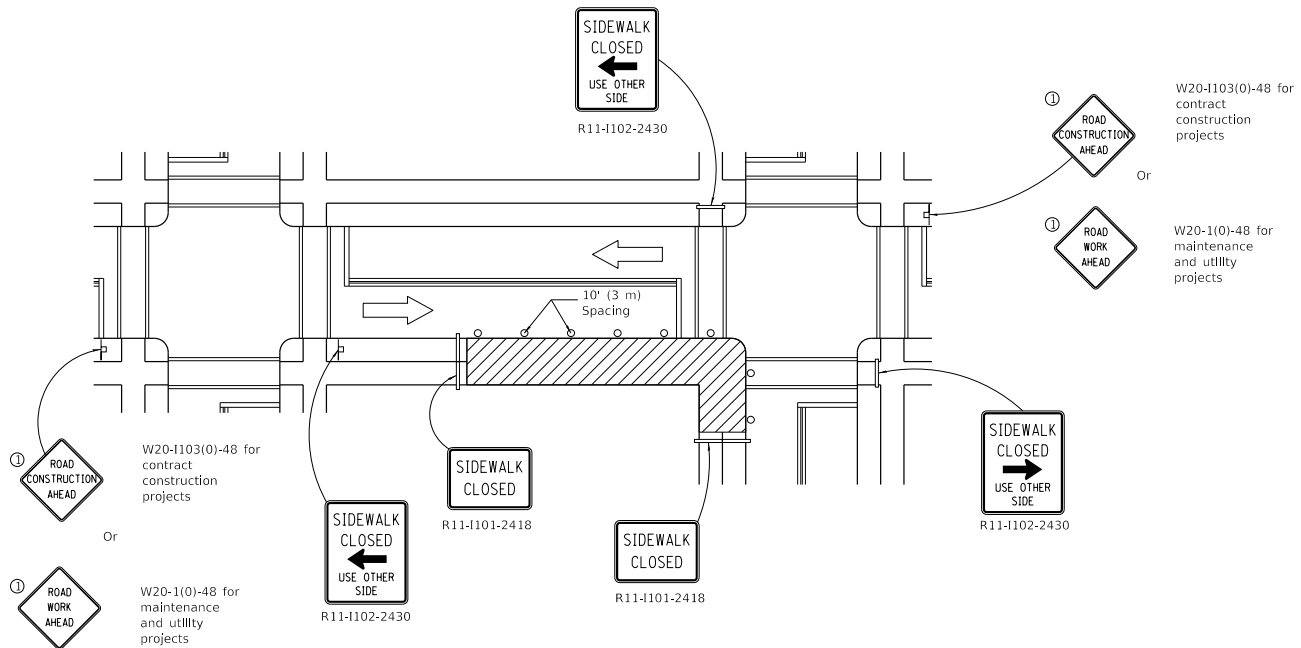

**CORNER CLOSURE**

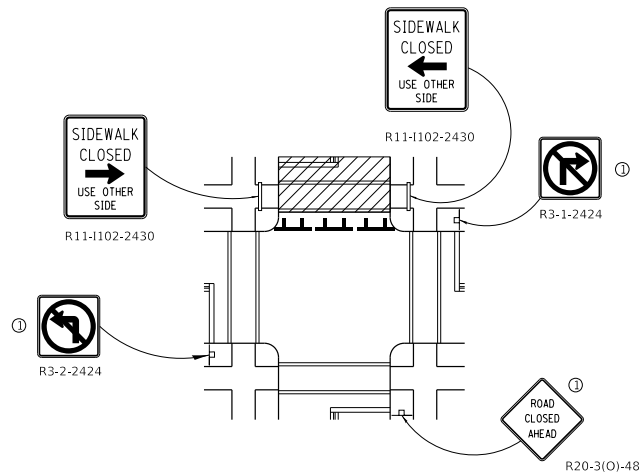

**CROSSWALK CLOSURE**

**SIDEWALK, CORNER OR CROSSWALK CLOSURE**

(Sheet 2 of 2)

Illinois Department of Transportation

PASSED *[Signature]* April 1, 2016  
 ENGINEER OF SAFETY ENGINEERING

APPROVED *[Signature]* April 1, 2016  
 ENGINEER OF DESIGN AND ENVIRONMENT

ISSUED 1-1-97



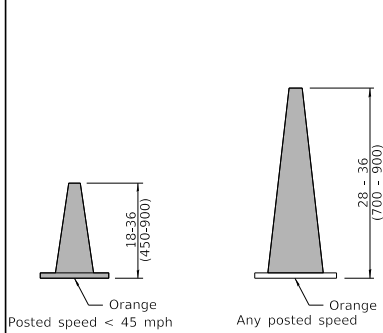

**DAYTIME USE**

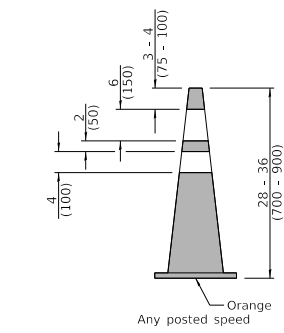

**CONES**

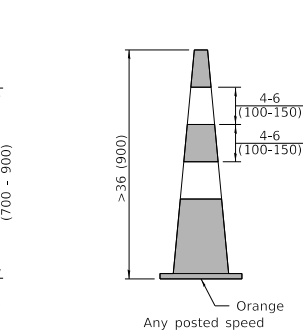

**DAY OR NIGHTTIME USE**

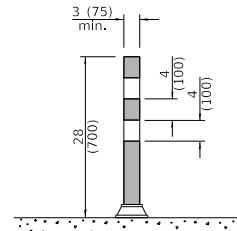

**TUBULAR MARKER**

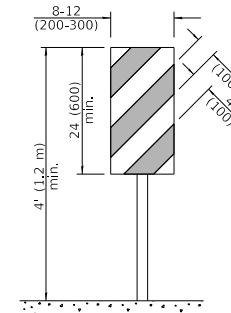

**VERTICAL PANEL  
POST MOUNTED**

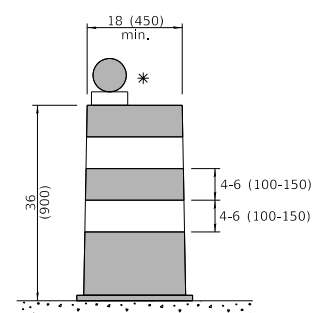

**DRUM**

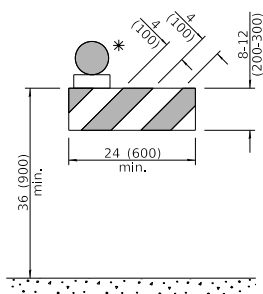

**TYPE I BARRICADE**

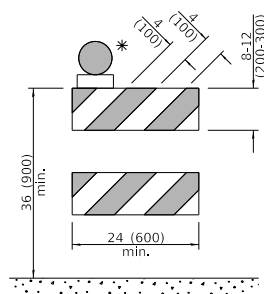

**TYPE II BARRICADE**

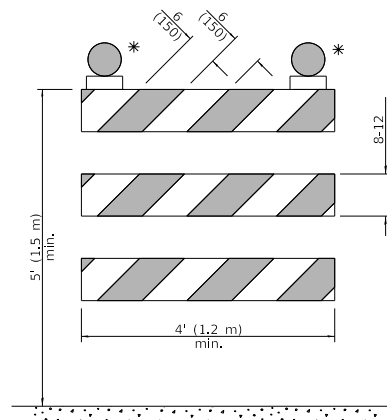

**TYPE III BARRICADE**

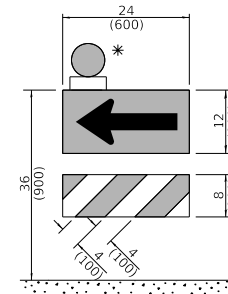

**DIRECTION INDICATOR  
BARRICADE**

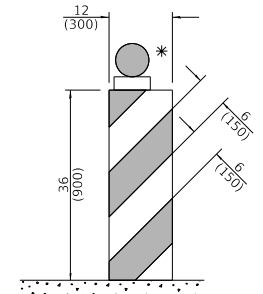

**VERTICAL BARRICADE**

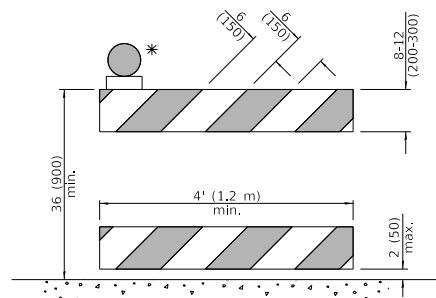

**DETECTABLE PEDESTRIAN  
CHANNELIZING BARRICADE**

\* Warning lights (if required)

**GENERAL NOTES**

All heights shown shall be measured above the pavement surface.

All dimensions are in inches (millimeters) unless otherwise shown.

DATE	REVISIONS
1-1-19	Revised cone usage and added cones >36" (900 m) height.
1-1-18	Revised END WORK ZONE SPEED LIMIT sign from orange to white background.

**TRAFFIC CONTROL DEVICES**

(Sheet 1 of 3)

**STANDARD 701901-08 161**

Illinois Department of Transportation

APPROVED January 1, 2019

ENGINEER OF SAFETY PROG. AND ENGINEERING

APPROVED January 1, 2019

ENGINEER OF DESIGN AND ENVIRONMENT

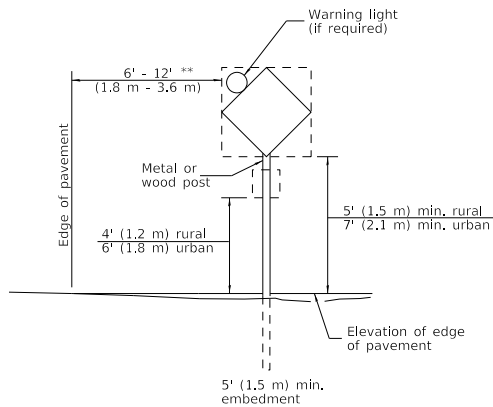

**POST MOUNTED SIGNS**

\*\* When curb or paved shoulder are present this dimension shall be 24 (600) to the face of curb or 6' (1.8 m) to the outside edge of the paved shoulder.

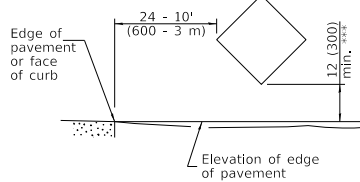

**SIGNS ON TEMPORARY SUPPORTS**

\*\*\* When work operations exceed four days, this dimension shall be 5' (1.5 m) min. If located behind other devices, the height shall be sufficient to be seen completely above the devices.

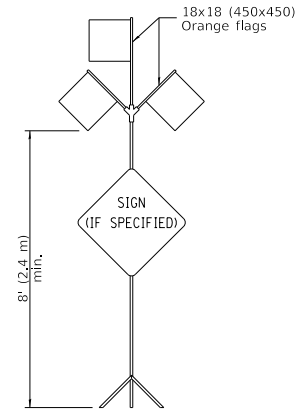

**HIGH LEVEL WARNING DEVICE**

ROAD  
CONSTRUCTION  
NEXT X MILES

G20-1104(0)-6036

END  
CONSTRUCTION

G20-1105(0)-6024

This signing is required for all projects 2 miles (3200 m) or more in length.

ROAD CONSTRUCTION NEXT X MILES sign shall be placed 500' (150 m) in advance of project limits.

END CONSTRUCTION sign shall be erected at the end of the job unless another job is within 2 miles (3200 m).

Dual sign displays shall be utilized on multi-lane highways.

**WORK LIMIT SIGNING**

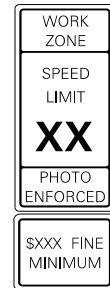

W21-1115(0)-3618

R2-1-3648

R10-1108p-3618 \*\*\*\*

R2-1106p-3618

Sign assembly as shown on Standards or as allowed by District Operations.

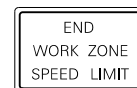

G20-1103-6036

This sign shall be used when the above sign assembly is used.

**HIGHWAY CONSTRUCTION SPEED ZONE SIGNS**

\*\*\*\* R10-1108p shall only be used along roadways under the jurisdiction of the State.

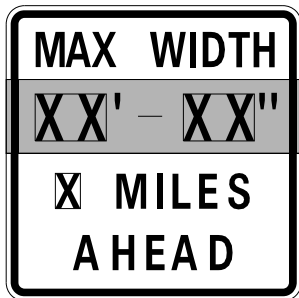

W12-1103-4848

**WIDTH RESTRICTION SIGN**

XX'-XX" width and X miles are variable.

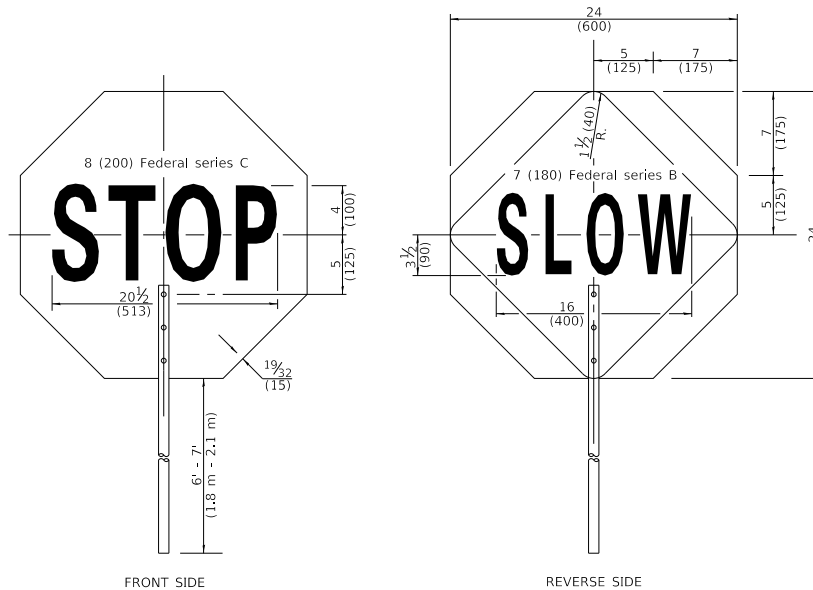

**FLAGGER TRAFFIC CONTROL SIGN**

Illinois Department of Transportation

APPROVED January 1, 2019  
*Cynthia A. ...*  
 ENGINEER OF SAFETY PROG. AND ENGINEERING

APPROVED January 1, 2019  
*...*  
 ENGINEER OF DESIGN AND ENVIRONMENT

**TRAFFIC CONTROL DEVICES**

(Sheet 2 of 3)

STANDARD 701901-08 162

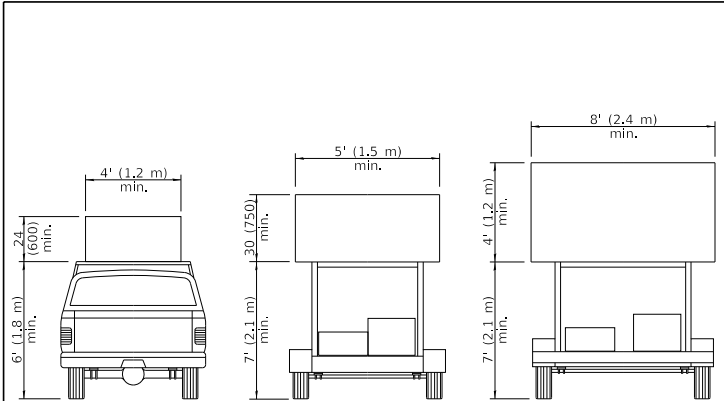

**TYPE A ROOF MOUNTED**  
**TYPE B ROOF OR TRAILER MOUNTED**  
**TYPE C TRAILER MOUNTED**

**ARROW BOARDS**

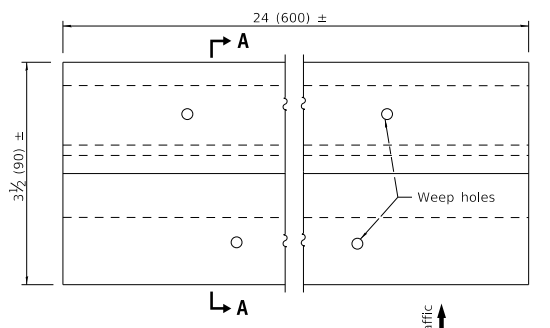

**PLAN**

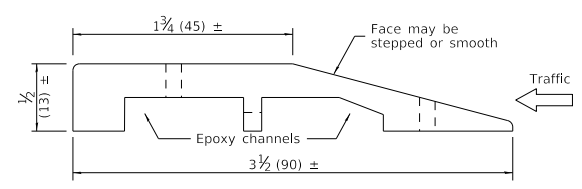

**SECTION A-A**

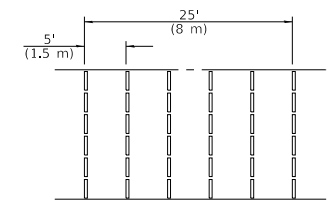
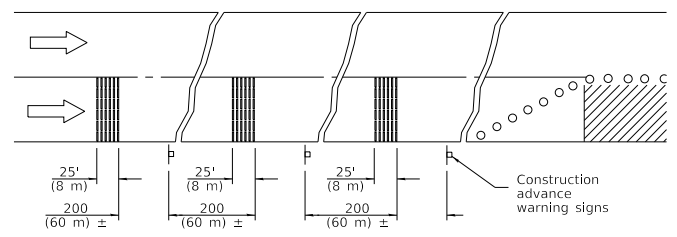

**TYPICAL INSTALLATION**

**TEMPORARY RUMBLE STRIPS**

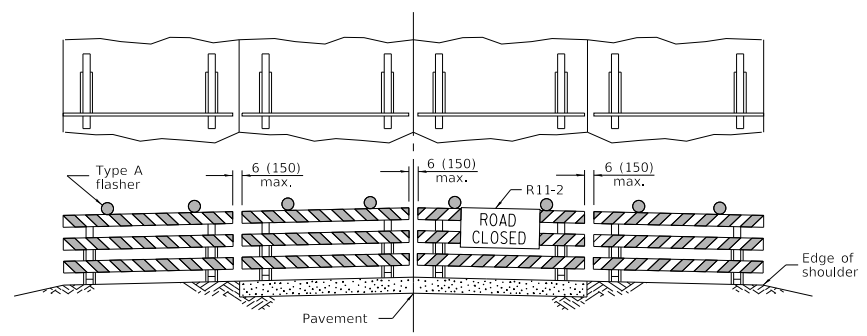

**ROAD CLOSED TO ALL TRAFFIC**

ReflectORIZED striping may be omitted on the back side of the barricades. If a Type III barricade with an attached sign panel which meets NCHRP 350 is not available, the sign may be mounted on an NCHRP 350 temporary sign support directly in front of the barricade.

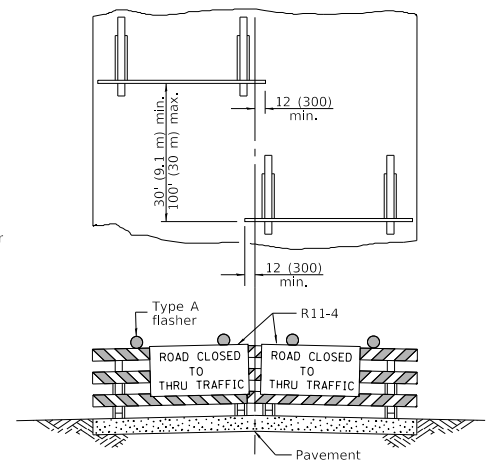

**ROAD CLOSED TO THRU TRAFFIC**

ReflectORIZED striping shall appear on both sides of the barricades. If a Type III barricade with an attached sign panel which meets NCHRP 350 is not available, the signs may be mounted on NCHRP 350 temporary sign supports directly in front of the barricade.

**TYPICAL APPLICATIONS OF TYPE III BARRICADES CLOSING A ROAD**

**TRAFFIC CONTROL DEVICES**

(Sheet 3 of 3)

Illinois Department of Transportation  
 APPROVED January 1, 2019  
 ENGINEER OF SAFETY PROG. AND ENGINEERING  
 APPROVED January 1, 2019  
 ENGINEER OF DESIGN AND ENVIRONMENT



MODEL: 780-3 (REV) 3 (REV) 10/18/2018  
 FILE NAME: I:\PROJECTS\2018\URBAN\_PAVEMENT\_MARKING\780-3 STANDARD DETAILS\_780-3 (REV) 10/18/2018 WORK\_ZONE - SIGNING - PAVEMENT MARKING.dwg

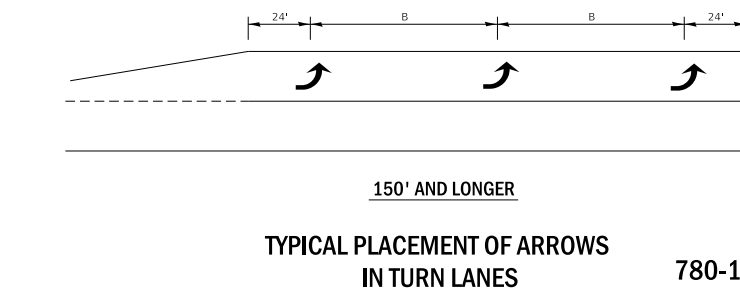
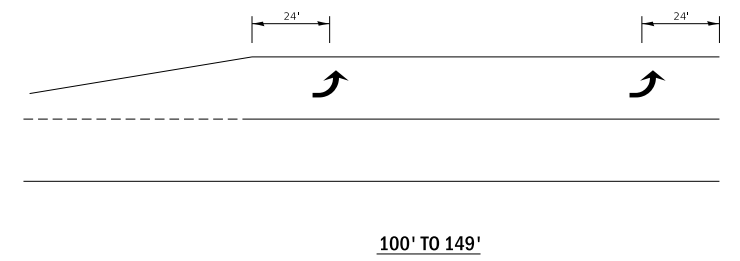
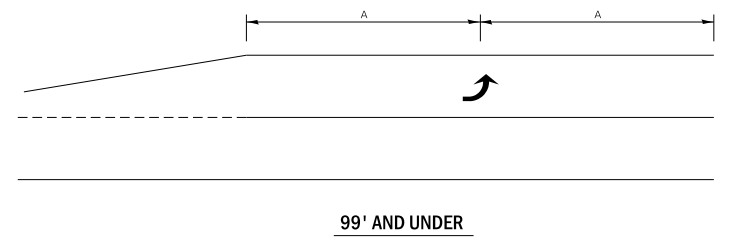
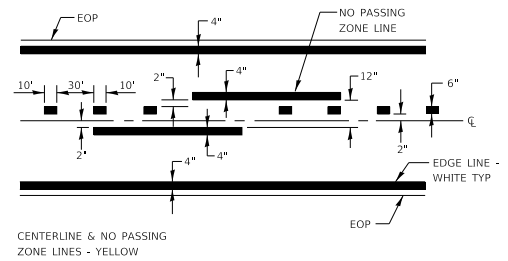
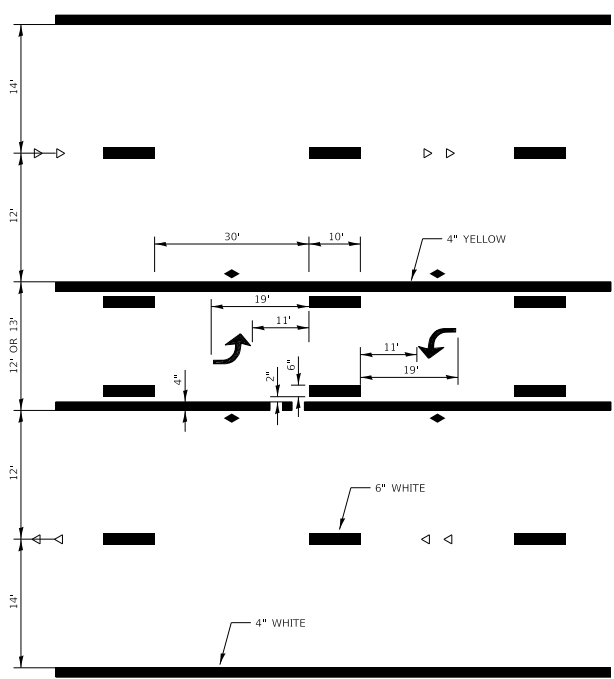
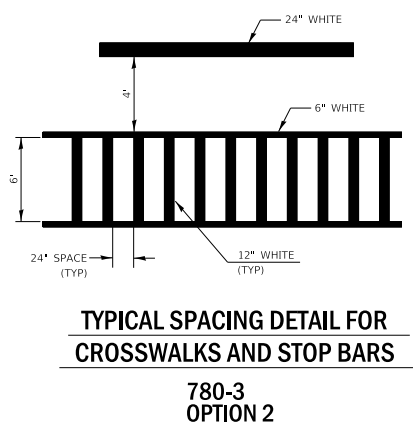
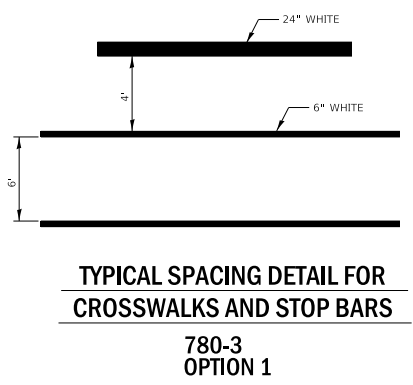

# URBAN PAVEMENT MARKING

USER NAME	DESIGNED	REVISIONS
DRAWN	CHECKED	DATE
PLOT SCALE	DATE	

**STATE OF ILLINOIS  
DEPARTMENT OF TRANSPORTATION**

URBAN PAVEMENT MARKING				F.A. SITE	SECTION	COUNTY	TOTAL SHEETS
SCALE:	SHEET	OF	SHEETS	STA.	TO STA.	CONTRACT	165
ILLINOIS FED. AID PROJECT							

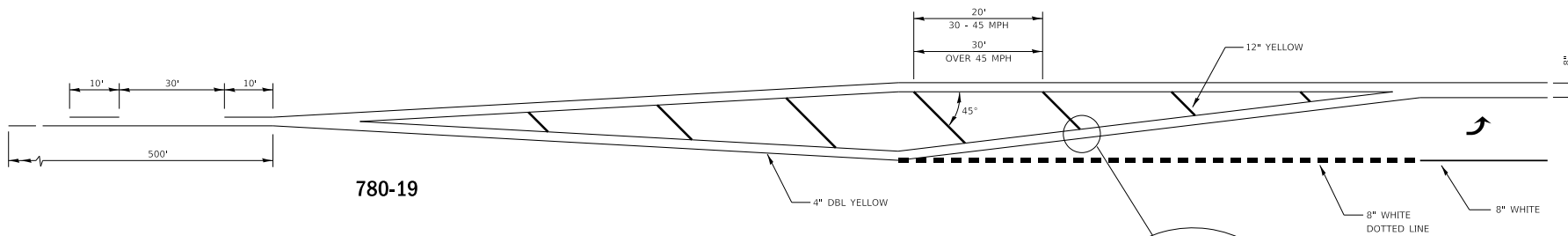

780-19

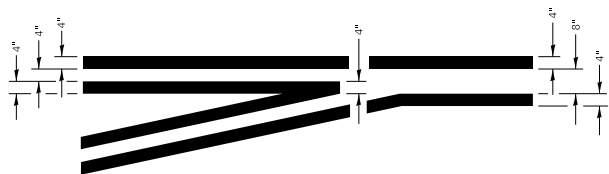

TYPICAL APPLICATION  
@ LEFT TURN LANES

780-1

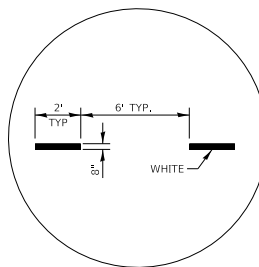
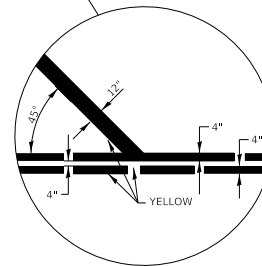

ADVANCE AND INTERSECTION LANE  
DIVIDER LINES

780-5

# URBAN PAVEMENT MARKING

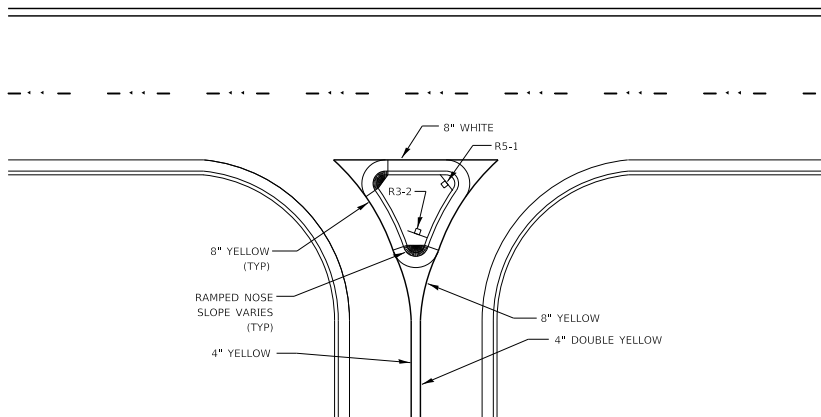

RIGHT IN RIGHT OUT ACCESS PAVEMENT MARKING 780-16

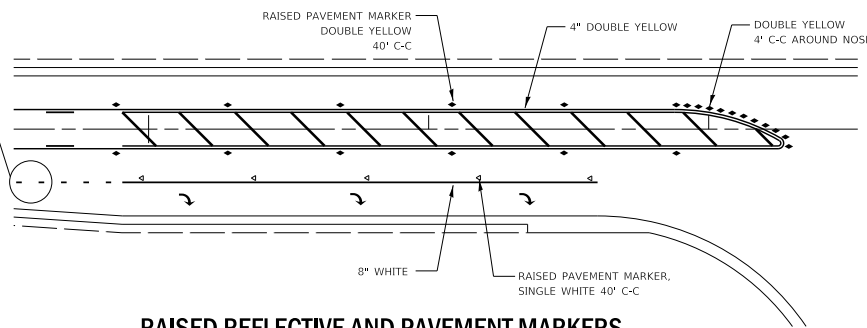

RAISED REFLECTIVE AND PAVEMENT MARKERS  
@ RIGHT TURN LANE

781-1

MODEL: 001 3 0401K  
 FILE NAME: I:\PROJECTS\2018\20180418\20180418\_URBAN\_PAVEMENT\_MARKING.dwg  
 USER: JLD  
 DATE: 4/18/2018 10:58:10 AM  
 PLOT DATE: 4/18/2018 10:58:10 AM  
 PLOT SCALE: 1/8" = 1'-0"

USER NAME	DESIGNED	REVISED
DRAWN	REVISIONS	
CHECKED	REVISIONS	
DATE	REVISIONS	

STATE OF ILLINOIS  
DEPARTMENT OF TRANSPORTATION

URBAN PAVEMENT MARKING

SCALE: SHEET OF SHEETS STA. TO STA.

F.A. SITE	SECTION	COUNTY	TOTAL SHEET
			166
CONTRACT			
ILLINOIS FED. AID PROJECT			

**AGENDA ITEM**

**MEETING TYPE:** Village Board  
**MEETING DATE:** June 18, 2019  
**SUBJECT:** Tree Removal Services Contract Award

**ACTION REQUESTED:**

Approval of a Resolution Authorizing the Execution of a Four (4) Year Contract with Busted Knuckles Landscape, Sheridan, IL, for Tree Removal Services for Various Areas Throughout the Village.

**BOARD/COMMISSION REVIEW:**

N/A

**ACTION PREVIOUSLY TAKEN:**

Date of Action	Meeting Type	Action Taken
N/A	N/A	N/A

**DEPARTMENT:** Public Works

**SUBMITTED BY:** Carri Parker, Purchasing Manager

**FISCAL IMPACT:**

Account: #1006040-542415 Tree Removal Service  
 Total Amount Budgeted in FY2020: \$30,000

Savings of \$60,445 versus using Village employees to perform the work, including at least \$1,880 for the same services from our previous contractor.

**BACKGROUND:**

Tree maintenance is one of the primary responsibilities of the Public Works Department. Under certain circumstances, a tree must be removed based on a safety concern, or aesthetics for the Village of Oswego. Currently, Public Works staff removes small- to medium-size trees and hires a contractor to perform stump grinding for \$10/inch. Staff obtains quotes on an as-needed basis to remove large trees that either requires personnel to climb the trees or which require larger equipment to remove.

Due to the lack of staff within the public works department, there is a backlog of 168 stumps (2120 inches) that need to be removed throughout the Village. As a result, the Village joined the

Oswego Township’s invitation to bid for tree removal services throughout the entire township and village.

**DISCUSSION:**

On April 12, 2019, the Oswego Township and the Village of Oswego held a public bid opening for tree trimming and removal services for various areas throughout Oswego. The township received three (3) bids: Busted Knuckles Landscaping, Pessina Tree Services, and Arborworks. The bid tab is attached for reference. Busted Knuckles Landscaping, LLC, located in Sheridan, IL, was the lowest responsible bidder. Per the terms of the bid document, each agency will award a contract for their work separately. The township subsequently is scheduled to award their portion of the contract on June 24, 2019.

The Village is only interested in contracting for tree removal services and emergency tree services. The emergency specifications state that the contractor must be provided twenty-four (24) hours’ notice of the said project and will have it completed within a twenty-four (24) hour period. The tree removal services are for dead, diseased, hazardous, and inappropriate species trees. The tree removal services include the removal of the tree, removal of branches, brush, and chips, stump grinding, removal of chips after stump grinding, placement of topsoil and grass seed.

Table 1 (below) shows the services received in FY2019 compared to what they would cost with this new contract if the same services were received through Busted Knuckles Landscaping, LLC.

**Table 1: Tree Services Comparison**

Type of Work - # of Items	In-House*	Contractor	Busted Knuckles	Difference
			Comparable prices	
Tree pruning - 792	\$ 62,325			
Tree removal – 114 Trees	\$ 10,755	\$ 11,100	\$ 46,605	\$ 24,750
Stump grinding – 2,287 inches		\$ 22,870		\$ (22,870)
<b>Total</b>	<b>\$ 73,080</b>	<b>\$ 33,970</b>	<b>\$ 46,605</b>	<b>\$ (60,445)</b>

\*Please note: The In-house cost does not include equipment costs, transportation costs, supply purchases and cost for brush disposal.

Analyzing these costs\*, the Village would be saving \$60,445 versus using Village employees to perform the work, including at least \$1,880 for the same services with Busted Knuckles Landscaping, LLC. There are opportunity costs by outsourcing the tree services, as Village staff will be able to focus efforts on increasing the number of pruned trees while addressing other Village priorities. Should the Village not be satisfied with the services received from Busted Knuckles Landscaping, LLC for any reason, the Village can cancel the contract as stated in the contract language.



The advantages of this contract are several folds: 1) we will continue to outsource stump grinding while adding tree removal services; 2) we will have a contractor in place, ready to deal with emergency tree removal without taking time to obtain a quote for each tree 2) we increase the likelihood that we will be reimbursed from FEMA should a declared disaster occur since the contract is in place prior to an emergency declaration.

Per the Mayor's request, I reached out to SD308 to seek their interest in this contract. After speaking with them, they are not interested in tree removal services but are interested in emergency services. I contacted Josh Lesko, owner of Busted Knuckles Landscaping, LLC, and he has agreed to uphold the bid pricing to these two organizations. As a result, I will develop a piggybacking clause that will allow any other governmental organization within the Village limits to be able to contract with Busted Knuckles Landscaping, LLC at the prices provided in the competitive bid process through the Township. Each organization will need to enter into their own agreement, but it is possible for the other entities to obtain the same pricing.

Due to the significant reduction in the Emerald Ash Borer program over the years, Staff has budgeted \$30,000 for FY2020 Tree Removal Services. This will be utilizing Busted Knuckles Landscaping for larger projects that staff is not able to perform this fiscal year. This budgeted amount does not include any emergency services that may arise. To assist with the removal of existing stumps that throughout the Village, Purchasing Manager Parker, has reached out to the United City of Yorkville to borrow their stump grinder as part of the shared services agreement between the two municipalities. Village staff will remove the existing stumps, while Busted Knuckles Landscaping will remove the stump when they remove the tree. This will reduce any safety concerns and increase the aesthetics of the Village by having these areas fully restored.

**RECOMMENDATION:**

Staff requests the Board approves the resolution authorizing the execution of a four (4) year contract with Busted Knuckles Landscape, Sheridan, IL, for tree removal services for various areas throughout the Village.

**ATTACHMENTS:**

- Resolution
- Exhibit A – Tree Removal Services Contract
- Exhibit B – Bid Tab

+ Village of Oswego

Oswego Road District OTB 0219 Bid Tabulations 4/12/19 9:00 AM

Year	Vendor 1				Vendor 2				Vendor 3			
	BUSTED KNUCKLES LAND. LLC				PESSINA TREE SERV				ARBORWORKS			
	STT	NSTT	ETT	TR/ <sub>IN.</sub>	STT	NSTT	ETT	TR	STT	NSTT	ETT	TR
2019	\$ 195. <sup>00</sup>	\$ 195. <sup>00</sup>	\$ 275. <sup>00</sup>	\$ 25. <sup>00</sup>	\$ 244. <sup>00</sup>	\$ 244. <sup>00</sup>	\$ 319. <sup>00</sup>	\$ 35. <sup>00</sup>	\$ 265. <sup>00</sup>	\$ 275. <sup>00</sup>	\$ 275. <sup>00</sup>	\$ 45. <sup>00</sup>
2020	\$ 204. <sup>75</sup>	\$ 204. <sup>75</sup>	\$ 285. <sup>00</sup>	\$ 25. <sup>00</sup>	\$ 257. <sup>00</sup>	\$ 251. <sup>00</sup>	\$ 328. <sup>57</sup>	\$ 36. <sup>00</sup>	\$ 278. <sup>00</sup>	\$ 289. <sup>00</sup>	\$ 289. <sup>00</sup>	\$ 47. <sup>25</sup>
2021	\$ 215. <sup>00</sup>	\$ 215. <sup>00</sup>	\$ 300. <sup>00</sup>	\$ 25. <sup>00</sup>	\$ 258. <sup>00</sup>	\$ 258. <sup>00</sup>	\$ 338. <sup>43</sup>	\$ 37. <sup>45</sup>	\$ 292. <sup>00</sup>	\$ 303. <sup>00</sup>	\$ 303. <sup>00</sup>	\$ 49. <sup>00</sup>
2022	\$ 215. <sup>00</sup>	\$ 215. <sup>00</sup>	\$ 300. <sup>00</sup>	\$ 27. <sup>00</sup>	\$ 266. <sup>03</sup>	\$ 266. <sup>03</sup>	\$ 348. <sup>58</sup>	\$ 38. <sup>57</sup>	\$ 307. <sup>00</sup>	\$ 318. <sup>00</sup>	\$ 318. <sup>00</sup>	\$ 52. <sup>10</sup>

INSURANCE  
NO PACKET

BID BOND  
ENTIRE CONTRACT  
INSURANCE

NO INSURANCE  
NO PACKET

**RESOLUTION NO. 19 - R - \_\_\_\_**

---

**RESOLUTION AUTHORIZING THE EXECUTION OF A FOUR-YEAR  
CONTRACT WITH BUSTED KNUCKLES LANDSCAPE, SHERIDAN, IL,  
FOR TREE REMOVAL SERVICES FOR VARIOUS AREAS  
THROUGHOUT THE VILLAGE**

---

**WHEREAS**, the Village of Oswego (“Village”) has a population of more than 25,000 and is therefore a “Home Rule Unit” under the 1970 Illinois Constitution; and

**WHEREAS**, the Illinois Constitution of 1970 provides that a Home Rule Unit may exercise any power and perform any function pertaining to its government and affairs, including but not limited to the power to regulate for the protection of the public health, safety, morals and welfare; to license, to tax; and to incur debt; and

**WHEREAS**, it is in the best interest of the Village of Oswego to enter into a four-year contract with Busted Knuckles Landscaping, LLC for tree removal services substantially in the form attached hereto marked aa “Exhibit A”.

**NOW, THEREFORE, BE IT RESOLVED BY THE PRESIDENT AND BOARD OF TRUSTEES OF THE VILLAGE OF OSWEGO, KENDALL AND WILL COUNTIES, ILLINOIS**, as follows:

**SECTION 1. INCORPORATION OF RECITALS**

That the recitals set forth above are incorporated here by reference.

**SECTION 2. SUPPORT FOR AGREEMENT**

The Village President and Village Board of Trustees hereby authorize a four-year contract with Busted Knuckles Landscaping, LLC for tree removal services substantially in the form attached as “Exhibit A” and direct the Village Administrator to execute the contract on behalf of the Village.

**SECTION 3. REPEALER**

All Resolutions or parts of Resolutions in conflict with any of the provisions of this Resolution shall be, and the same hereby repealed to the extent of the conflict.

**SECTION 4. SEVERABILITY**

This Resolution and every provision thereof shall be considered severable. If any section, paragraph, clause or provision of this Resolution is declared by a court of law to be invalid or unconstitutional, the invalidity or unconstitutionality thereof shall not affect the validity of any other provisions of this Resolution.

**SECTION 5. EFFECTIVE DATE**

This Resolution shall be in full force and effect from and after its passage.

**PASSED** by the Board of Trustees of the Village of Oswego, Kendall and Will Counties, Illinois this 18<sup>th</sup> day of June 2019.

JAMES MARTER	_____	LUIS PEREZ	_____
TERRY OLSON	_____	JUDY SOLLINGER	_____
PAM PARR	_____	BRIAN THOMAS	_____

**APPROVED** by me, Troy Parlier, as President of the Village of Oswego, Kendall and Will Counties, Illinois this 18<sup>th</sup> day of June 2019.

\_\_\_\_\_  
TROY PARLIER, VILLAGE PRESIDENT

\_\_\_\_\_  
TINA TOUCHETTE, VILLAGE CLERK

STATE OF ILLINOIS     )  
                                  )  
COUNTY OF KENDALL    )       SS

**CLERK'S CERTIFICATE**  
**(RESOLUTION)**

I, Tina Touchette, the duly qualified and acting Village Clerk of the Village of Oswego, Kendall and Will County, Illinois, do hereby certify that I am the keeper of its books and records and that the attached hereto is a true and correct copy of a Resolution entitled:

**RESOLUTION AUTHORIZING THE EXECUTION OF A FOUR-YEAR  
CONTRACT WITH BUSTED KNUCKLES LANDSCAPE, SHERIDAN, IL,  
FOR TREE REMOVAL SERVICES FOR VARIOUS AREAS  
THROUGHOUT THE VILLAGE.**

which Resolution was duly adopted by said Board of Trustees at a regular meeting held on the 18<sup>th</sup> day of June 2019, and thereafter approved by the Village President on the 18<sup>th</sup> day of June 2019.

I do further certify, in my official capacity, that a quorum of said Board of Trustees was present at said meeting and that the Board complied with all requirements of the Illinois Open Meetings Act.

IN WITNESS WHEREOF, I have hereunto set my hand this 18<sup>th</sup> day of June 2019.

\_\_\_\_\_  
Tina Touchette, Village Clerk  
Village of Oswego

(Seal)



## Request for Bids

Tree trimming and removal for various areas throughout  
the Oswego Township and the Village of Oswego

OTB: 0219

By Order Of:

Oswego Township Road District

Village of Oswego Public Works

## Table of Contents

- I. Legal Notice to Bidders
- II. Instructions to Bidders
- III. Project Specifications
- IV. Bid Certifications
- V. References
- VI. Subcontractors
- VII. Equipment List
- VIII. Maps
- IX. Bid Sheets
- X. Appendix

**LEGAL NOTICE**

**REQUEST FOR SEALED BIDS**

**Tree trimming and removal for various areas throughout the Oswego Township and the Village of Oswego.**

**OTB: 0219**

Sealed proposals for tree trimming and removal throughout the Oswego Township will be received at the address listed below until Friday April 12<sup>th</sup> 2019 at 9:00 A.M. Proposals will be publically opened and read aloud at the above stated time and place. Proposals not physically received by the Township by 9:00 A.M. on Friday April 12<sup>th</sup> 2019 will be returned, unopened to the firm. Emailed or faxed proposals will not be accepted. All proposals should be addressed to:

**Oswego Township Road District**

**Re: (vendor name)**

**OTB: 0219**

**Attention: Highway Commissioner**

**84 Templeton Dr. Suite 104**

**Oswego IL 60543**

Bid packets will be available for pickup at two locations 84 Templeton Dr. Suite #104 Oswego, IL 60543 and 1150 Rt. 25 Oswego, IL 60543. They will also be available upon request via email to [mailbox@oswegotownship.org](mailto:mailbox@oswegotownship.org)

If required each bid must be accompanied by a Bid Guarantee in the form of a Bid Bond from a company with an A-1 best rating, or a cashier's check in the amount of ten percent (10%) of the total amount of the proposal and made payable to the Township of Oswego, Highway Department 84 Templeton Dr. Oswego, IL 60543. No bid shall be withdrawn for a period of thirty (30) days after the bid opening date without the consent of the Township. Checks or drafts of unsuccessful bidders will be returned as soon as possible after opening and checking the proposals.

This bid is **NOT** subject to the prevailing wage act. For further information or clarification please visit the Illinois Department of Labor's website.

The Township reserves the right to reject any or all proposals and to waive any informality in bidding.

Award of the Contract: The Oswego Township Highway Commissioner will make the final award of the proposal. The successful bidder and the Township will execute a contract mutually agreeable to both parties within 14 days from the award of bid.



## Instructions to Bidders:

### 1. *Receipt of Bid:*

9:00 A.M. Friday April 12<sup>th</sup> 2019

### 2. *Basis of Bid:*

Sealed bids will be received until the above date and time.

### 3. *Participating Agencies:*

- a. The Oswego Township Road District, 1150 Route 25, Oswego, IL 60543
- b. The Village of Oswego Public Works Department, 100 Theodore Lane Oswego, IL 60543.

### 4. *Bid Description:*

Tree trimming for various areas throughout the Oswego Township and the Village of Oswego.

### 5. *Preparation and Submission of Bids:*

- a. Bids are to be submitted by Friday April 12<sup>th</sup> 2019 at the Oswego Township office located at 84 Templeton Dr. Suite 104 Oswego, IL 60543. Bid Opening to take place at 9:01 A.M. Friday April 12<sup>th</sup> 2019 at the location noted above.
- b. Each bid shall be submitted on the exact forms furnished by the Oswego Township. All blank spaces for bid prices, unit costs and alternates must be filled out in either black or blue ink. In any discrepancy in the amount bid, the prices written out in words shall supersede the figures written.
- c. Each bidder must complete, execute and submit with its bid a certification that contractor is not barred from public contracting due to bid-rigging or bid rotating convictions on the form included with the bidding documents.
- d. Each bidder must submit a complete bid package. If an incomplete package is submitted that Oswego Township Road District reserves the right to dismiss the bid submittal.

- e. The bid shall be submitted in an opaque sealed envelope on or before the stated time and shall bear the name of the individual(s), firm or corporation submitting the bid.
- f. Bidders may attach separate sheets to the bid for the purpose of explanation, exception, alternate items or to cover unit prices if needed.
- g. Bidders may withdraw their bid either personally or by written request at any time before the bid opening and may resubmit it. No bid may be withdrawn or modified after the bid opening except where the award of contract has been delayed for a period of ninety (90) or more days.
- h. In submitting the bid, the bidder further declares that the only person or party interested in the proposal as principals are those names herein; and that the bid is made without collusion with any other person, firm or corporation.
- i. The bidder further declares that they have carefully examined this entire bid package and they familiarized themselves with all of the local conditions affecting the contract and detailed requirements of this work and understand that in making the bid they waive all rights to plead a misunderstanding regarding the same.
- j. The bidder further understands and agrees that if their bid is accepted they are to furnish and provide all necessary machinery, tools, and apparatus. And other means to do all of the work and to furnish all of the materials specified in the contract, except such materials as are to be furnished by the owner (Road District), in the manner and the time therein prescribed, and in accordance with the requirements therein set forth.
- k. The bidder further agrees that if the Road District decides to extend or shorten the work or otherwise alter it by extras or deductions, including elimination of one or more of the items, as provided in the specifications, they will perform the work as altered, increased or decreased.
- l. The bidder agrees that the Road District representative may at any time, during the progress of the work covered by this contract, order other work or materials incidental thereto and that all such work and materials as do not appear in the bid or contract as a specific item covered by a lump sum price, and which are not included under the bid price for other items in the contract, shall be performed as extra work.
- m. The bidder agrees to complete all work no later than the "Time of Completion" stated in their bid after receipt of the "Notice to Proceed" unless otherwise provided, and to execute the work in such a manner and with sufficient materials, equipment and labor as will insure its completion within the time limit specified within the bid, it being understood and agree that completion within the time limit is an essential part of the contract. *WEATHER PERMITTING*
- n. By submitting a bid, the bidder understands and agrees that if their bid is accepted and they fail to enter a contract forthwith, they shall be liable to the Road District for any damages the Road District may suffer as a result of this failing.

6. *Substitutions:* N/A

7. *Conditions:*

- a. The Road District and Village of Oswego are exempt from Federal excise tax and the Illinois Retailers Occupation tax. This bid cannot include any amounts of money for these taxes.
- b. To be valid, the bids shall be itemized so that selection for purchase may be made, there being included in the price of each unit the cost of delivery (FOB Destination).
- c. The Road District and Village of Oswego shall reserve the right to add or to deduct from the base bid and/or alternate bid any item at the prices indicated in the itemization of the bid.
- d. All bids shall be good for ninety (90) days from the date of bid opening.

8. *Basis of Award:*

- a. The Road District reserves the right to reject any or all bids and to waive an informality or technical error and to accept any bid deemed most favorable to the interest of the Township of Oswego. In addition to price, the Road District will also consider the following qualifications/conditions:
  - i. Ability, capacity and skill to fulfill the contract as specified.
  - ii. Ability to supply the commodities, provide the services or complete the construction promptly or within the time specified without delay or interference.
  - iii. Character, integrity, reputation, judgement, experience and efficiency.
  - iv. Quality of performance with previous contracts.
  - v. Previous and existing compliance with laws and ordinances relating to the contract
  - vi. Sufficiency of financial resources.
  - vii. Quality, availability and adaptability of the commodities, services or construction, in relation to the Road District's requirements.
  - viii. Ability to provide future maintenance and service under the contract.
  - ix. Number and scope of conditions attached to the bid/proposal.
  - x. Record of payments for taxes, licenses or other monies due to the Road District.

9. *Insurance Requirements:*

- a. The Contractor will be required to meet the Oswego Township insurance requirements. Unless otherwise specified the Contractor shall, before commencing, satisfactory to the

Oswego Township an additionally named insured in the following minimum amounts with specific coverage which includes underground, explosion, and collapse.

- b. Workmen's Compensation Insurance:
  - i. All Liability imposed by Workmen's Compensation statute
    - 1. Employer's Liability Insurance \$1,000,000
    - 2. Contractual Liability Insurance \$1,000,000
    - 3. Completed Operations Insurance \$ 500,000
- c. Owned, Hired, and Non-Ownership Vehicle, Bodily Injury and Property Damage to the following Limits:
  - i. Commercial General Liability \$2,000,000 (each occurrence)
  - ii. Bodily Injury \$2,000,000 (each person) \$2,000,000 (each accident)
  - iii. Property Damage \$2,000,000 (each accident)
  - iv. Automobile Liability \$1,000,000 combined single limit (each accident)
  - v. Umbrella Liability \$3,000,000 (each occurrence) \$3,000,000 (aggregate)

*10. Guarantee:*

The Contractor will also forward copies of all applicable manufactures warranties for all equipment/commodities supplied by the contractor as part of the contract.

*11. Payment:*

The Contractor will be responsible for following the payment procedures for each specific government entity.

*12. Indemnification:*

The contractor shall protect, indemnify, save, defend and hold forever harmless the Road District and/or its officers, officials, employees, volunteers and agents from and against all liabilities, claims, damages, penalties, causes of action, costs and expenses including without limitation court costs, insurance, deductibles, and attorney's fees and expenses, which the Road District and its officers, officials, employees, volunteers and agents may incur, suffer, sustain or for which the Road District and its officers, officials, employees, volunteers, and agents may become obligated by reason for any accident injury to or death of persons or loss of or damage to property, or civil and/or constitutional infringement of rights (specifically including violations of the Federal Civil Rights Statute), arising indirectly or directly in connection with or under, or as a result of, this or any agreement by virtue of any act or omission of any of the contractor's officers, employees, volunteers, subcontractor and/or agents provided that the contractor shall not be liable for claims, obligations, damages, penalties, causes of action, costs and expenses arising solely by any act or omission of the Road District's officers, officials, employees, volunteers or agents.

*13. Safety:*

The contractor and any subcontractors shall comply with all provisions of the Federal Occupational Safety and Health Act of 1970 (84 Stat. 1590) as amended. Contractors and any subcontractors shall be required to follow the MUTCD regarding any signage requirements and are responsible for knowing such requirements for the specific project. The contractor and any subcontractor are also required to follow any OSHA or Illinois Department of Labor law postings or requirements.

*14. Execution of Documents:*

- a. The contractor in signing the bid documents on the whole or on any portion of the work shall conform to the following requirements:
  - i. A bid signed by an individual other than the individual represented in the bid documents shall have attached thereto a power of attorney evidencing authority to sign the bid in the name of the person for whom it is signed.
  - ii. A bid signed for a partnership shall be signed by all of the partners or by an attorney-in-fact. If signed by an attorney-in-fact, there shall be attached to the bid a power of attorney evidencing authority to sign the bid, executed by the partners.
  - iii. A bid signed for a corporation, shall have the correct corporate name thereof and signature of the president or other authorized officer of the corporations manually written below the corporate name.
  - iv. If such bid is manually signed by an official other than the president of the corporation, a certified copy of a resolution of the board of directors evidencing the authority of such official to sign the bid should be attached to it, Such bid shall also bear the attesting signature of the secretary of the corporation and the impression of the corporate seal. The contract shall be deemed as have been awarded when formal notice of award shall have been duly served upon the intended awardee.

## Project Specifications

### *Purpose:*

The purpose of this bid is to set a best practice tree trimming schedule in place for various areas of the Oswego Township Road District. In keeping with best practice tree trimming and tree removal procedures the Road District increases cost effectiveness, safety and aesthetics.

### *Contract Duration:*

The Road District requires a four (4) year contract in order to represent best tree trimming practices. The Road District and Village of Oswego reserve the right to terminate the contract with the contractor for any reason.

### *Contract Specifications:*

Any changes, alterations or substitutions to any of the requirements laid out in this bid package must be filled out on the "Alterations/Substitutions" sheet in appendix B.

It is the contractor's duty to inspect the area(s) involved in this bid package and evaluate them as needed. The Road District will not be held liable or responsible for any miss-information on behalf of the contractor.

The contractor must inform the Road District Commissioner/Public Works Director or designated appointee one (1) day before any work, besides emergency work, is performed.

All mobilization costs for any work performed shall be included in bid price.

Any damage done while work is being performed by contractor must be repaired by the contractor to the original or a like new state.

Contractor is responsible for hauling away all chips, and shall include cost in price per hour.

Henceforth, in this document the Road Commissioner and Village of Oswego Public Works Director shall be referred to as "Supervisor".

### *Terms Defined:*

Scheduled Tree Trimming: Tree trimming that is scheduled in this bid packet. A drawn out 4 year schedule of maintenance for tree trimming throughout the Oswego Township.

Non-Scheduled Tree Trimming: Tree trimming in areas that are not drawn out in this bid packet that may occur throughout the subsequent years.

Emergency Tree Trimming: Tree trimming that is given less than a twenty-four (24) hour notice to the contractor.

Tree Removal: The removal of a tree that is either dead, diseased, hazardous, or is no longer provides enough benefit for the cost of maintaining the tree or infrastructure surrounding the tree.

Diameter- Measurement standard used when determining tree removal prices.

DBH- Diameter at Breast Height. Trees should be measured at this level when determining the price for removal.

*Scheduled Tree Trimming:*

The Oswego Township Road District has chosen to adopt a policy that revolves around 4 year rotating schedule for tree maintenance throughout the Oswego Township. The Road District requires an ISA certified arborist to be on site while conducting scheduled tree trimming.

Pruning of trees shall be done for both health and safety purposes. The Road District supports a healthy and safe tree maintenance program to minimize recurring costs and maximize tree efficiency and aesthetics. Tree pruning shall be done in accordance with best arborist practices prioritizing safety, then health, then aesthetics. Crown raising pruning technique shall be done to ensure safety for pedestrians and trucks.

Pruning shall be done when trees are in a dormant state, beginning no earlier than December 1<sup>st</sup> and ending no later than March 1<sup>st</sup>. Any work performed shall begin after 8:00 A.M. and end before 5:30 P.M. Monday through Saturday, there shall be no scheduled tree work performed on Sundays.

Tree trimming crews shall be comprised of three (3) workers at least one must be an ISA certified arborist. Tree trimming crews should have all the necessary equipment to do the work performed including but not limited to; bucket truck with 55' reach, and a brush chipper with 250 HP and 20" diameter intake.

Chip disposal shall be included in the price per hour.

Scheduled tree trimming schedule can be found on appendix A.

**For the purposes of this bid, only the Oswego Township Road District will be participating in the scheduled tree trimming portion.**

*Non-Scheduled Tree Trimming:*

Non-scheduled tree trimming is defined as tree trimming not scheduled in this bid package but scheduled at least one working week (5 days) in advance at any point throughout the contract duration.

Non-scheduled tree trimming does NOT require an ISA certified arborist to be on site.

Pruning of trees shall be done for both health and safety purposes. The Road District/Village of Oswego supports a healthy and safe tree maintenance program to minimize recurring costs and maximize tree efficiency and aesthetics. Tree pruning shall be done in accordance with best

arborist practices prioritizing safety, then health, then aesthetics. Crown raising pruning technique shall be done to ensure safety for pedestrians and trucks.

Any work performed shall begin after 8:00 A.M. and end before 5:30 P.M. Monday through Saturday, there shall be no scheduled tree work performed on Sundays.

Tree trimming crews shall be comprised of three (3) workers. Tree trimming crews should have all the necessary equipment to do the work performed including but not limited to; bucket truck with 55' reach, and a brush chipper with 250 HP and 20" diameter intake.

Chip disposal shall be included in the price per hour.

Time and place of tree trimming shall be given to the contractor at least one working week (5 days) in advance of work being performed. The Road District/Village of Oswego and the contractor may work out a time for tree trimming to take place that works in the best interest of both parties. But may not exceed 1 month from the date of first notice.

#### *Emergency Tree Trimming*

Emergency tree trimming is defined as tree trimming that must take place within twenty-four (24) hours of notice given by the Road District/Village of Oswego. The time to complete the tree trimming starts at the time of the first call given by the Road District/Village of Oswego.

Emergency tree trimming does NOT require an ISA certified arborist on site.

Emergency tree trimming crews shall be comprised of, at least, two (2) workers. Tree trimming crews should have all the necessary equipment to do the work performed including but not limited to; bucket truck with 55' reach, and a brush chipper with 250 HP and 20" diameter intake.

Chip disposal shall be included in the price per hour.

Time and place of emergency tree trimming shall be given to the contractor twenty-four (24) hours in advance by the Road District/Village of Oswego. The contractor must complete the work within the twenty-four (24) hours of first notice.

#### *Tree Removal:*

Tree removal shall be performed at the request of the Road District/Village of Oswego or by the notification of the contractor while performing tree trimming duties. Reasons for the removal of a tree are as follows:

- Dead
- Diseased
- Hazardous to human health and property
- Damaging current infrastructure.



- The cost of maintaining the tree outweighs the benefit of the tree.

While performing tree trimming duties the contractor must contact the supervisor or designated appointee and notify them before the removal of a dead, diseased or hazardous tree. The supervisor or designated appointee shall be given appropriate time to inspect the tree and verify the condition of said tree.

Tree removal price shall be calculated using Diameter at Breast Height (DBH) or for general rule 1.3 meters above the ground. For the purposes of this bid package tree removal prices are calculated on a per diameter inch basis.

*Cleanup and Restoration:*

The contractor shall perform the removal of the tree, removal of brush, branches and chips, stump grinding, removal of chips after stump grinding, and placement of top soil and grass seed. All work shall be included in the price per inch.

Stumps should be ground down to a minimum depth of six inches (6") and a minimum width of six inches (6") past the edge of the stump at ground level. All surface roots must be removed. After grinding and chip removal contractor must place a cone in hole made from grinding until such time restoration is completed.

Restoration shall include the placement of top soil to match grade, there must be allotment for settling, and placement of contractors' grade Kentucky Blue grass seed.

Stump grinding and chip removal shall take place no later than five (5) days after the tree has been removed.

Restoration should take place no more than five (5) days after chip removal (weather permitting) and cone placement. In the event that weather does not permit the completion of restoration, the contractor will provide the address to the supervisor or designated appointee.

## CONTRACT

This contract is entered into this 16<sup>th</sup> day of June 2019, by and between the Village of Oswego (Village) and Busted Knuckles Landscaping, LLC (Contractor).

The entire bid package together with all Exhibits and attachments and following sections apply to all proposals requested and accepted by the Village and become a part of the contract unless otherwise specified. The Village assumes that submission of a proposal means that the person submitting the proposal has familiarized himself with all conditions and intends to comply with them unless noted otherwise.

1. **Definitions:** The definitions set forth in the Bid Packet are incorporated herein.
2. **Conditions:** The Contractor is responsible for being familiar with all conditions, instructions, and documents governing this project and bid. Failure to make such investigation and preparations shall not excuse the Contractor from performance of the duties and obligations imposed under the terms of this contract.
3. **Billing/Invoicing:** All billing and invoicing will be at the completion of the job with detailed itemized billing. Billing will include the date, the work performed, and the total cost. After receipt of a correct invoice, payments shall be due and owing by the Village in accordance with the terms and provisions of the Local Government Prompt Payment Act, Illinois Compiled Statutes, Ch. 50, Sec. 505, et. seq.;

If, in the opinion of the Village, the Contractor has not or is not satisfactorily performing the work covered by this specification, and within forty-eight (48) hours of receipt of a written demand from the Village, for performance, has not cured any defect in performance specifically itemized in such demand, the Village may, at its option:

- A. Withhold payment.
- B. Consider all or any part of this contract breached and terminate the contractor, or
- C. May hire another contractor to cure any defects in performance or complete all work covered by this specification for the remaining term of this contract.
- D. Any demand for performance shall be specifically delivered to contractor by personal delivery, certified or registered mail.

The Village will make periodic inspections and follow up as needed with the contractor to discuss any issues, etc.

4. **Insurance Requirements:** The Contractor will provide satisfactory proof of insurance naming the Village, together with their officers, agents, employees and engineers as additional primary, non-contributory named insureds prior to commencing work. All policies shall be written on a "per occurrence" basis. The Contractor shall procure and maintain

insurance for protection from claims under worker's compensation acts, claims for damages because of bodily injury including personal injury, sickness or disease or death of any and all employees or of any person other than such employees, and from claims or damages because of injury to or destruction of property including loss of use resulting therefrom, alleged to arise from the Contractor's or its officers's, agent's, employee's negligence in the performance of services under this Agreement. Contractor's certificate of insurance shall contain a provision that the coverage afforded under the policy(s) will not be canceled or reduced without thirty (30) days prior written notice (hand delivered or registered mail) to the Village. Contractor shall promptly forward new certificate(s) of insurance evidencing the coverage(s) required herein upon annual renewal of the subject policies. Failure of the Contractor to supply a valid certificate of insurance, or if a previously valid certificate of insurance has expired and is not replaced, is grounds for issuance of a stop work order until such time as a valid certificate of insurance is provided. Failure of the Village to collect or demand a certificate of insurance shall not be deemed a waiver of the requirement to provide one.

The limits of liability for the insurance required by this Subsection shall not be less than the following:

**Workmen's Compensation Insurance:**

All Liability imposed by Workmen's Compensation statute

Employer's Liability Insurance	\$1,000,000
Contractual Liability Insurance	\$1,000,000
Completed Operations Insurance	\$ 500,000

Owned, Hired, and Non-Ownership Vehicle, Bodily Injury and Property Damage to the following Limits:

Commercial General Liability	\$2,000,000 (each occurrence)
Bodily Injury	\$2,000,000 (each person) \$2,000,000 (each accident)
Property Damage	\$2,000,000 (each accident)
Automobile Liability	\$1,000,000 combined single limit (each accident)
Umbrella Liability	\$3,000,000 (each occurrence) \$3,000,000 (aggregate)

5. **Force Majeure:** Whenever a period of time is provided for in this Agreement for the Contractor or the Village to do or perform any act or obligation, neither party shall be liable for any delays or inability to perform if such delay is due to a cause beyond its control and without its fault or negligence including, without limitation: a) Acts of nature; b) Acts or

failure to act on the part of any governmental authority other than the Village or Contractor, including, but not limited to, enactment of laws, rules, regulations, codes or ordinances subsequent to the date of this Agreement; c) Acts of war; d) Acts of civil or military authority; e) Embargoes; f) Work stoppages, strikes, lockouts, or labor disputes; g) Public disorders, civil violence, or disobedience; h) Riots, blockades, sabotage, insurrection, or rebellion; i) Epidemics or pandemics; j) Terrorist acts; k) Fires or explosions; l) Nuclear accidents; m) Earthquakes, floods, hurricanes, tornadoes, or other similar calamities; n) Major environmental disturbances; or o) Vandalism. If a delay is caused by any of the force majeure circumstances set forth above, the time period shall be extended for only the actual amount of time said party is so delayed. Further, either party claiming a delay due to an event of force majeure shall give the other party written notice of such event within three (3) business days of its occurrence or it shall be deemed to be waived.

6. **Liquidated Damages:** Time is of the essence to the contract. Should the Contractor fail to complete the work within the specified time stipulated in the contract or within such extended time as may have been allowed, the Contractor shall be liable and shall pay to the Village the amount shown in the schedule of deductions, not as a penalty but as liquidated damages, for each day of overrun in the contract time or such extended time as may have been allowed. The liquidated damages for failure to complete the contract on time are approximate, due to the impracticality of calculating and proving actual delay costs. This schedule of deductions establishes the cost of delay to account for administration, engineering, inspection, supervision and other costs and expenses during periods of extended and delayed performance. The costs of delay represented by this schedule are understood to be a fair and reasonable estimate of the costs that will be borne by the Village during extended and delayed performance by the Contractor of the work. The liquidated damage amount specified will accrue and be assessed until final completion of the total physical work of the contract even though the work may be substantially complete.
7. **Contract Term:** The contract will commence as of the date of this contract and expire on April 30, 2022.
8. **Change Orders:** After contract is awarded, additional purchases or modifications may be made under the contract, or the terms of the contract may be extended, without rebidding the materials, supplies, services or equipment involved, provided that the change order:
  - A. Is not of such a size or nature as to undermine the integrity of the original bidding process; and
  - B. Is germane to the original contract; and
  - C. Does not exceed twenty percent (20%) of the contracted amount; and
  - D. Is approved by the Board of Trustees or by the Village Administrator, or his/her designee for change orders that are not greater than fifteen thousand dollars (\$15,000.00).

9. **Compliance with Laws and Regulations:** In addition to the bid and performance bonds set forth above, the contractor must furnish and pay for satisfactory any other security required by law or by the specifications for this particular project. Upon receipt of the performance bond, the Village will return the bid bond to the contractor.
- A. The Contractor must comply with all applicable laws prerequisite to doing business in the state.
  - B. The Contractor must have a valid Federal Employer Tax Identification Number or Tax Identification Number (for individuals).
  - C. The Contractor must provide a Statement of Compliance with provisions of the State and Federal Equal Opportunity Employer requirements.
  - D. The Contractor must provide evidence of any professional or trade license required by law or local ordinance for any trade or specialty area in which the Contractor is seeking a contract award. Additionally, the Contractor must disclose any suspension or revocation of such license held by the company, or of any director, officer or manager of the company. Any material changes to the Contractor's status, at any time, must be reported in writing to the Village within 14 days of its occurrence. Failure to comply with this requirement is grounds for the Contractor to be deemed non-responsible.
10. **Independent Contractor:** There is no employee/employer relationship between the Contractor and the Village. Contractor is an independent contractor and not the Village's employee for all purposes, including, but not limited to, the application of the Fair Labors Standards Act minimum wage and overtime payments, Federal Insurance Contribution Act, the Social Security Act, the Federal Unemployment Tax Act, the Worker's Compensation Act (820 ILCS 305/1, et seq.). The Village will not (i) provide any form of insurance coverage, including but not limited to health, worker's compensation, professional liability insurance, or other employee benefits, or (ii) deduct any taxes or related items from the monies paid to Contractor. The performance of the services described herein shall not be construed as creating any joint employment relationship between the Contractor and the Village, and the Village is not and will not be liable for any obligations incurred by the Contractor, including but not limited to unpaid minimum wages and/or overtime premiums, nor does there exist an agency relationship or partnership between the Village and the Contractor.
11. **Approval and Use of Subcontractors:** The Contractor shall perform the Services with its own personnel and under the management, supervision, and control of its own organization unless otherwise approved by the Village in writing. All subcontractors and subcontracts used by the Contractor shall be in the discretion of the Village and in advance by the Village. The Village's approval of any subcontractor or subcontract shall not relieve the Contractor of full responsibility and liability for the provision, performance, and completion of the Work in full compliance with, and as required by or pursuant to, this Contract. If the Contractor chooses to use subcontractors to perform any of the Work, the Work performed under any subcontract shall be subject to all of the provisions of this Contract in the same manner as if performed by employees of the Contractor. Every reference in this Contract to

“Contractor” shall be deemed to also apply to all subcontractors of the Contractor. Every subcontract entered into by the Contractor to provide the Work or any part thereof shall include a provision binding the subcontractor to all provisions of this Contract.

- A. If any personnel or subcontractor fail to perform the part of the Work undertaken by it in a manner satisfactory to the Village, the Contractor shall immediately upon notice from the Village remove and replace such personnel or subcontractor. The Village shall have no claim for damages, for compensation in excess of the contract price, or for a delay or extension of the contract time as a result of any such removal or replacement.
12. **Assignment:** Neither the Village nor the Contractor shall assign or transfer any rights or obligations under this Agreement without the prior written consent of the other party.
  13. **Governing Law:** This Contract and the rights of Owner and Contractor under this Contract shall be interpreted according to the internal laws of the State of Illinois. Venue for any action related to this Contract will be in the Circuit Court of Kendall County, Illinois.
  14. **Changes in Law:** Unless otherwise explicitly provided in this Contract, any reference to laws shall include such laws as they may be amended or modified from time to time.
  15. **Time:** The Contract Time is of the essence of this Contract. Except where otherwise stated, references in this Contract to days shall be construed to refer to calendar days.
  16. **Termination:** The Village shall have the right at any time and for any reason (without any penalty) to terminate, in whole or in part, this Contract, provided that the Village shall provide Contractor at least thirty (30) days’ prior written notice of such termination whereupon this Agreement shall automatically terminate immediately after the 31st day.
    - A. When this contract, or any portion hereof, is terminated or cancelled by the Village, and the Contractor released before all items of work included in this contract have been completed, payment may be made be prorated as a percentage of completion of the actual work at contract unit prices, and no claims for loss of anticipated profits or other damages will be made and are hereby waived.
    - B. Termination of a contract, as stated above, will not relieve the Contractor or his/her surety of the responsibility of replacing defective work or materials.
  17. **Piggybacking Clause:** This contract may be used to perform any Work on facilities or properties under the jurisdiction of the Village of Oswego including, but not limited to, interior and exterior building renovations and repairs, site work, electrical, plumbing, HVAC, concrete, masonry, maintenance of bridges, roofing replacement and/or repairs, streetscape repairs and improvements to Village sites. This Contract may also be used as a joint purchase agreement between the Village, Oswego Community School District 308, Oswegoland Park District, Oswego Library District, Oswego Township, Oswego Fire

Protection District, as well as any other agencies participating in a shared services agreement with the Village.

18. **Additional Items:** The Village and Contractor further agree that

- A. Certifies that it is not barred from bidding or contracting with the Village as a result of a violation of either Paragraph 33E-3 (Bid rigging) or 33E-4 (Bid rotating) of Act 5, Chapter 720 of the Illinois Compiled Statutes regarding criminal interference with public contracting, and
- B. Swears under oath that it is not delinquent in the payment of any tax administered by the Illinois Department of Revenue as required by Chapter 65, Act 5, paragraph 11-42.1 of the Illinois Compiled Statutes, and
- C. States that it has a written sexual harassment policy as required by the Illinois Human Rights Act (775 ILCS 5/2-105(A) (4)) a copy of which shall be provided to the Village upon request, and
- D. Agrees to comply with the requirements of the Illinois Human Rights Act regarding Equal Employment Opportunities as required by Section 2-105 of the Illinois Human Rights Act (775 ILCS 5/2-105) and agrees to comply with the EQUAL EMPLOYMENT OPPORTUNITY CLAUSE in Appendix A, Section 750, Part 750, Chapter X, Subtitle B of Title 44 of the Illinois Administrative Code incorporated herein by reference, and
- E. Agrees to comply with the civil rights standards set forth in Title VII of the Civil Rights Act as mandated in Executive Order No. 11246, U.S.C.A. Section 2000e n.114 (September 24, 1965), and
- F. Agrees to comply with the Substance Abuse Prevention on Public Works Projects Act (820 ILCS 265/1 et seq.) if this Project is a "public work" within the meaning of the Illinois Prevailing Wage Act (820 ILCS 130/.01 et seq.) and prohibit substance abuse while performing such work and has a substance abuse prevention program, and
- G. Agrees to provide a drug free workplace pursuant to the Drug Free Workplace Act (30 ILCS 580/1 et seq.) (25 or more employees under a contract of more than \$5,000 or for individuals only when greater than \$5,000), and
- H. Agrees to comply with the Employment of Illinois Workers on Public Works Act (30 ILCS 570/0.01 et seq.) and employ Illinois laborers if at the time of this contract is executed or if during the term of this contract there is excessive unemployment in Illinois as defined in the Act.

19. **Indemnity and Hold Harmless Agreement:** To the fullest extent permitted by law, Contractor shall indemnify, defend, save and hold the Village, their trustees, officers, employees, agents, attorneys and lenders (collectively the "Indemnitees") harmless from and against all loss and expense (including, but not limited to, reasonable attorney's fees and other costs and expenses) by reason of any liability or allegation of liability, against the Indemnitees, or any of them, for damages because of property damage or bodily injury, occupational sickness or disease, including death, resulting therefrom, while performing the work or while at the site where work under the Contract is being conducted or elsewhere, while engaged in the performance of Work under the Contract, however such injuries may be caused, whether attributable to a breach of statutory duty or administrative regulation

or otherwise, and such injuries for which liability is imputed to the Indemnitees, or any of them, or damage or injury, directly or indirectly arising or alleged to arise out of the performance of or the failure to perform the work or the failure to protect the work or the site, or the condition of the work, the site, adjoining land or driveways, or streets or alleys used in connection with the performance of the work. Without limiting the generality of the foregoing, the defense and indemnity set forth in this section includes, subject only to the limitations contained in this section, all liabilities, damages, losses, claims, demands and actions on account of bodily injury, death or property loss to an Indemnitee or to any other person or entities, whether based upon, or claimed to be based upon, statutory, contractual, tort or other liability of any Indemnitee. In addition, such defense and indemnity shall include all liabilities, damages, losses, claims, demands and actions for defamation, false arrest, malicious prosecution or any other infringement or similar rights.

The provisions of the indemnity provided for herein shall not be construed to indemnify any Indemnitee for its own negligence or to the extent not permitted by law or to eliminate or reduce any other indemnification, right or remedy which the Village is otherwise entitled to assert. This provision shall survive completion, expiration, or termination of this Agreement.

If any claim indemnified hereunder has not been settled or discharged when the work is completed, final payment of the Contract Sum shall not be due, unless and until Contractor provides a bond or other security equal to 150% of the amount of such claim in a form and substance satisfactory to the Village. In any and all claims against any Indemnitee or any of its agents or employees by any employee of Contractor, anyone directly or indirectly employed by him or anyone for whose acts he may be liable, the indemnification obligation under this Section shall not be limited in any way by any limitation on the amount or type of damages, compensation or benefits payable by or for Contractor under Worker's Compensation acts or other employees benefit acts.



**CONTRACT SIGNATURES**

IN WITNESS WHEREOF the parties hereto have executed or caused to be executed by their duly authorized agents, this contract in DUPLICATE, each of which shall be deemed original, on the day and year first written.

\_\_\_\_\_  
Village of Oswego Administrator Date

\_\_\_\_\_  
Attest Title

\_\_\_\_\_  
Busted Knuckles Landscaping LLC  
(Printed Name of Contractor)

\_\_\_\_\_  
2994 N 4201<sup>st</sup> Road  
Address

\_\_\_\_\_  
Sheridan IL 60551  
City State Zip Code

\_\_\_\_\_  
*Ashua Lesto*  
Signature of Authorized Representative

\_\_\_\_\_  
*Owner* *6-10-19*  
Title Date

## Professional References

Name:	Fox Township
Address:	8495 Fox River Dr., Millbrook IL
Phone:	815-483-6401
Contact:	Brad Mathre

Name:	Little Rock Township
Address:	611 W Main St. Plano IL 60545
Phone:	630-552-3304
Contact:	Richard Wade

Name:	Dekalb Co Forest Preserve (Sannauk)
Address:	15250 US-34 Sandwich, IL 60548
Phone:	815-751-4886      815-901-5787
Contact:	Terry Hannan , Scott Suda

## Subcontractor List

Name:	
Address:	
Phone:	
Contact:	

Name:	
Address:	
Phone:	
Contact:	

Name:	
Address:	
Phone:	
Contact:	

## Equipment List

1. 2006 International 4300 75' Elevator forestry truck
2. 1992 GMC Topkick 6500 60' LRII Altec forestry truck
3. 1993 GMC Topkick 6500 20 Yrd chip truck
4. 2003 Verbarck Hurricane 2400 20" chipper
5. '96 Vermeer BC1250 12" chipper
6. 2001 Rayco 1625 stump grinder
7. 2018 PJ 16' 20K Dump trailer
8. 2000 PJ 14' 14K Dump trailer
9. 2007 New holland C190 track skid steer
10. 2003 New holland LS190 wheel skid steer
11. 2002 F450 Dump truck
12. 2002 Chevy 2500HD service truck
13. 2012 GMC 3500HD Pick up.
14. 1992 Farmhand F8926 tub grinder
15. Various Saws and climbing gear

# Road District/Village of Oswego Bid Sheet: Tree Trimming and Removal

## Tree Trimming Scheduled Maintenance (Road District Only):

Year:	2019	2020	2021	2022
Price Per Hour:	\$195 <sup>00</sup>	\$204.75	\$215 <sup>00</sup>	\$215 <sup>00</sup>

## Tree Trimming Non-Scheduled Work (5 days advanced notice):

Year:	2019	2020	2021	2022
Price Per Hour:	\$195 <sup>00</sup>	\$204.75	\$215 <sup>00</sup>	\$215 <sup>00</sup>

## Tree Trimming Emergency Work:

Year:	2019	2020	2021	2022
Price Per Hour:	\$275 <sup>00</sup>	\$285 <sup>00</sup>	\$300 <sup>00</sup>	\$300 <sup>00</sup>

## Tree Removal Price (Diameter)

Year:	2019	2020	2021	2022
Price Per Inch:	\$25	\$25	\$25	\$27

Contractor: Busted Knuckles Landscaping LLC

Address: 2994 W 4201<sup>st</sup> rd Sheridan, IL 60551

Phone: 630-608-7007

Fax: —

Email: Lesko93@gmail.com

Authorized Agent Signature: 

Date: 3-28-19





# CERTIFICATE OF LIABILITY INSURANCE

DATE (MM/DD/YYYY)  
04/05/2019

THIS CERTIFICATE IS ISSUED AS A MATTER OF INFORMATION ONLY AND CONFERS NO RIGHTS UPON THE CERTIFICATE HOLDER. THIS CERTIFICATE DOES NOT AFFIRMATIVELY OR NEGATIVELY AMEND, EXTEND OR ALTER THE COVERAGE AFFORDED BY THE POLICIES BELOW. THIS CERTIFICATE OF INSURANCE DOES NOT CONSTITUTE A CONTRACT BETWEEN THE ISSUING INSURER(S), AUTHORIZED REPRESENTATIVE OR PRODUCER, AND THE CERTIFICATE HOLDER.

**IMPORTANT:** If the certificate holder is an ADDITIONAL INSURED, the policy(ies) must have ADDITIONAL INSURED provisions or be endorsed. If SUBROGATION IS WAIVED, subject to the terms and conditions of the policy, certain policies may require an endorsement. A statement on this certificate does not confer rights to the certificate holder in lieu of such endorsement(s).

<b>PRODUCER</b> Crum-Halsted Agency Inc 100 South Latham St Suite 101 Sandwich IL 60543		<b>CONTACT NAME:</b> Jordan Pinehar <b>PHONE (A/C, No, Ext):</b> (815) 786-2105 <b>FAX (A/C, No):</b> (815) 786-2512 <b>E-MAIL ADDRESS:</b> jpinehar@crumhalsted.com	
<b>INSURED</b> Busted Knuckles Landscaping LLC 2994 N 4201st Rd Sheridan IL 60551		<b>INSURER(S) AFFORDING COVERAGE</b>	
		INSURER A : Westfield Insurance	NAIC # 24112
		INSURER B : Pekin Insurance Company	24228
		INSURER C : Liberty Mutual Insurance Co	23043
		INSURER D :	
		INSURER E :	
		INSURER F :	

COVERAGES      CERTIFICATE NUMBER: 2019 - 2020      REVISION NUMBER:

THIS IS TO CERTIFY THAT THE POLICIES OF INSURANCE LISTED BELOW HAVE BEEN ISSUED TO THE INSURED NAMED ABOVE FOR THE POLICY PERIOD INDICATED. NOTWITHSTANDING ANY REQUIREMENT, TERM OR CONDITION OF ANY CONTRACT OR OTHER DOCUMENT WITH RESPECT TO WHICH THIS CERTIFICATE MAY BE ISSUED OR MAY PERTAIN, THE INSURANCE AFFORDED BY THE POLICIES DESCRIBED HEREIN IS SUBJECT TO ALL THE TERMS, EXCLUSIONS AND CONDITIONS OF SUCH POLICIES. LIMITS SHOWN MAY HAVE BEEN REDUCED BY PAID CLAIMS.

INSR LTR	TYPE OF INSURANCE	ADDL INSD	SUBR WVD	POLICY NUMBER	POLICY EFF (MM/DD/YYYY)	POLICY EXP (MM/DD/YYYY)	LIMITS
A	<input checked="" type="checkbox"/> COMMERCIAL GENERAL LIABILITY <input type="checkbox"/> CLAIMS MADE <input checked="" type="checkbox"/> OCCUR GEWL - AGGREGATE LIMIT APPLIES PER <input type="checkbox"/> POLICY <input checked="" type="checkbox"/> PROJECT <input type="checkbox"/> LOC <input type="checkbox"/> OTHER	Y		CWP024280R	03/19/2019	03/19/2020	EACH OCCURRENCE \$ 1,000,000 DAMAGE TO RENTED PREMISES (Eq occurrence) \$ 100,000 MED EXP (Any one person) \$ 5,000 PERSONAL & ADV INJURY \$ 1,000,000 GENERAL AGGREGATE \$ 2,000,000 PRODUCTS - COMPROP AGG \$ 2,000,000
B	<b>AUTOMOBILE LIABILITY</b> <input type="checkbox"/> ANY AUTO <input type="checkbox"/> OWNED AUTOS ONLY <input checked="" type="checkbox"/> HIRED AUTOS ONLY <input type="checkbox"/> SCHEDULED AUTOS <input checked="" type="checkbox"/> NON-OWNED AUTOS ONLY	Y		00P735661	03/19/2019	03/19/2020	COMBINED SINGLE LIMIT (Pa accident) \$ BODILY INJURY (Per person) \$ 1,000,000 BODILY INJURY (Per accident) \$ 1,000,000 PROPERTY DAMAGE (Per accident) \$ 1,000,000
	<b>UMBRELLA LIAB</b> <input type="checkbox"/> OCCUR <b>EXCESS LIAB</b> <input type="checkbox"/> CLAIMS MADE DED \$      RETENTION \$						EACH OCCURRENCE \$ AGGREGATE \$
C	<b>WORKERS COMPENSATION AND EMPLOYERS' LIABILITY</b> ANY PROPRIETOR PARTNER EXECUTIVE OFFICER/MEMBER EXCLUDED? (Mandatory in NH) If yes, describe under DESCRIPTION OF OPERATIONS below	Y/N	N/A	WC539S387540015	02/27/2019	02/27/2020	<input checked="" type="checkbox"/> PER STATUTE <input type="checkbox"/> OTHER E - EACH ACCIDENT \$ 500,000 E - DISEASE - EM-EMPLOYEE \$ 500,000 E - DISEASE - POLICY LIMIT \$ 500,000

DESCRIPTION OF OPERATIONS / LOCATIONS / VEHICLES (ACORD 101, Additional Remarks Schedule, may be attached if more space is required)  
It is agreed the Certificate holder is added as an additional insured with respects to the General Liability and Auto Liability when required by written contract.  
Umbrella follows form. Tree removal and tree trimming is covered under the insureds liability policy.

### CERTIFICATE HOLDER

### CANCELLATION

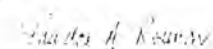
Oswego Township Road District Attn: Highway Commissioner 84 Templeton Dr. Suite 104 Oswego IL 60543	SHOULD ANY OF THE ABOVE DESCRIBED POLICIES BE CANCELLED BEFORE THE EXPIRATION DATE THEREOF, NOTICE WILL BE DELIVERED IN ACCORDANCE WITH THE POLICY PROVISIONS.  AUTHORIZED REPRESENTATIVE 
--	--



## ISA Certified Arborist® Exam Score Report

**CANDIDATE:** Josh Lesko

**CANDIDATE ID:** 267524

**REGISTRATION NUMBER:** 351689377

**EXAM:** ISA Certified Arborist® Exam

**DATE:** 4/3/19

**SITE:** 67769

**VALIDATION:** 350492031

**PASSING SCORE:** 76%

**CANDIDATE SCORE:** 85%

**GRADE:** pass

DOMAIN TITLE	DOMAIN SCORE
Soil Management	76%
Identification & Selection	93%
Installation & Establishment	100%
Safe Work Practices	85%
Tree Biology	78%
Pruning	79%
Diagnosis & Treatment	85%
Urban Forestry	83%
Tree Protection	100%
Tree Risk Management	86%

### Thank you for choosing Pearson VUE!

This examination was delivered at a Pearson VUE Authorized Center. For all your ISA testing needs, please contact your local Pearson VUE Authorized Center or visit our World Wide Web site at [www.pearsonvue.com/isa](http://www.pearsonvue.com/isa) or call 888-711-9958 (United States), 888-711-9958 (Canada). For phone numbers not listed, visit the web site.

**You Can Authenticate This Score Report Using Pearson VUE's Digital Embosser!** To maintain the integrity of this testing program and the value of your certification, Pearson VUE introduces Digital Embossing! Digital Embossing eliminates the possibility of unauthorized embossing of counterfeit score reports. To authenticate this score report, go to [www.pearsonvue.com/authenticate](http://www.pearsonvue.com/authenticate).





**AGENDA ITEM**

**MEETING TYPE:** Village Board

**MEETING DATE:** June 18, 2019

**SUBJECT:** Pedestrian Crossings on Washington Street

**ACTION REQUESTED:**

Approval of a Resolution Authorizing the Execution of a Professional Engineering Services Contract with Christopher B. Burke Engineering Ltd. in an Amount of \$94,500.00 for a Traffic Study of Washington Street

**BOARD/COMMISSION REVIEW:**

N/A

**ACTION PREVIOUSLY TAKEN:**

Date of Action	Meeting Type	Action Taken
11/13/2018	Committee of Whole	Discussion Regarding Pedestrian Crossings on Washington Street
6/18/19	Committee of Whole	Discussion Regarding Pedestrian Crossings on Washington Street

**DEPARTMENT:** Public Works

**SUBMITTED BY:** Public Works Director/Village Engineer Jennifer M. Hughes, P.E., CFM

**FISCAL IMPACT:**

FY20 Budget: \$80,000 – Project cost \$94,500 – net \$14,500 unbudgeted if quiet zone work is deferred for a year

**BACKGROUND:**

Pedestrian safety in the downtown is a high priority for the Village. We have a vision for a vibrant, welcoming downtown which cannot be fully realized unless it is easily and safely accessible for pedestrians. To that end, the Village has worked—and will continue to work—with the Illinois Department of Transportation (IDOT) to improve the convenience and safety of

pedestrian crossings. As Washington Street (US 34) is a state highway under IDOT's jurisdiction, any improvements along US 34 must be approved by IDOT.

IDOT late 2018/early 2019, IDOT completed a traffic signal warrant analysis and confirmed that the intersection still does not meet warrants for the signal. They offered that the Village could update the study to consider future traffic based upon community growth and downtown redevelopment. They stated that if we meet these future warrants, and if the public supports the signals despite the delays that will be caused by the signals, they then may authorize the signals to be constructed at the Village's cost.

The engineering for the traffic signals at Main and Harrison Streets is complex due to the proximity to signals at Madison Street, IL 31, and the railroad crossing. Each of these items needs to interact and ensure that intersections can clear when trains approach. In addition, IDOT has made it clear that we will also need to ensure that the intersections meet the requirements of the Americans with Disabilities Act.

In a separate but related project, the Village is working on establishing a railroad quiet zone through the downtown. This zone would create an environment where train engineers would not need to sound their horn except when they believe there is an imminent hazard. We would need to modify the railroad crossing signals on Washington and connect them the new traffic signals.

We incorporated the following projects into Capital Improvement Program:

- \$60,000 for design of traffic signals at Main and Harrison in FY20
- \$300,000 for construction of a traffic signal at Main in FY21
- \$300,000 for construction of a traffic signal at Harrison in FY22
- \$20,000, \$6,000, and \$1,174,000 for a railroad quiet zone through the downtown in FY20, 21, and 22, respectively.

We can use the funds for design to conduct the study.

## **DISCUSSION:**

Based upon Christopher B. Burke Engineering Ltd.'s experience working on the quiet zone study and their extensive background of completing similar studies, staff selected CBBEL for this work. The scope of the project includes:

1. Obtain vehicle and pedestrian counts sufficient to complete the study.
2. Working with the Community Development Department, use existing traffic, recognized growth factors such as those determined by CMAP, the Comprehensive Plan and forecasted development in the downtown to project future vehicle and pedestrian counts over a five- and ten-year planning horizons.
3. Prepare signal warrant analysis for each intersection under existing conditions and projected five and ten-year planning horizons.

4. Conduct modeling to determine impacts to corridor. Using traffic visualization software, prepare a video to help residents, public officials, and others understand the impacts.
5. Prepare engineering concept plans for each intersection in enough detail to:
  - a. Determine feasibility of construction of traffic signals including power sources, and
  - b. Identify and develop a plan to resolve any ADA impacts at the intersections.
6. Identify short term (30-90 days) actions that can be taken to improve pedestrian safety in the corridor.
7. Determine if a signal interconnect system will be required in the corridor that ties in train pre-emption for the crossing between Main and Harrison Streets.
8. Identify long term actions that could be taken to improve pedestrian safety should traffic signals not be approved at these locations.
9. Identify utility impacts for all options.
10. Prepare cost estimates for all options.
11. Identify permit requirements.
12. Conduct up to two public meetings to gather input from residents and the downtown business community. The purpose of the meetings is to gauge public support for alternative improvements for pedestrians that may increase delay for motorists. Exhibits to be presented included concept drawings of the traffic signals, traffic simulation results, and other documents to clearly demonstrate the options and impacts of improvements. Prepare a summary of the meetings and document resident input as preferences for the options.
13. Coordinate the scope of work with IDOT to ensure they will accept the proposed approach. Present a written report as well as meeting with IDOT and Village officials to discuss the results.

The scope does not include preparation of construction plans, construction plans, specifications, estimates, and bid documents for the Village and IDOT approved concept, bid services, or construction observation/documentation.

**RECOMMENDATION:**

Staff recommends approval of a contract with Christopher B. Burke Engineering Ltd.

**ATTACHMENTS:**

- Resolution No. 19 - R - \_\_\_\_ Authorizing PSA with CBBEL for Traffic Study
- Exhibit A – CBBEL PSA.pdf

**RESOLUTION NO. 19 - R - \_\_\_\_**

---

**RESOLUTION AUTHORIZING THE EXECUTION OF A PROFESSIONAL ENGINEERING SERVICES CONTRACT WITH CHRISTOPHER B. BURKE LTD, ROSEMONT, IL IN THE AMOUNT OF \$94,500.00 FOR A TRAFFIC STUDY OF WASHINGTON STREET**

---

**WHEREAS**, the Village of Oswego (“Village”) has a population of more than 25,000 and is therefore a “Home Rule Unit” under the 1970 Illinois Constitution; and

**WHEREAS**, the Illinois Constitution of 1970 provides that a Home Rule Unit may exercise any power and perform any function pertaining to its government and affairs, including but not limited to the power to regulate for the protection of the public health, safety, morals and welfare; to license, to tax; and to incur debt; and

**WHEREAS**, it is in the best interest of the Village of Oswego to approve the agreement substantially in the form attached hereto marked as “Exhibit A”.

**NOW, THEREFORE, BE IT RESOLVED BY THE PRESIDENT AND BOARD OF TRUSTEES OF THE VILLAGE OF OSWEGO, KENDALL AND WILL COUNTIES, ILLINOIS,** as follows:

**SECTION 1. INCORPORATION OF RECITAL**

That the recitals set forth above are incorporated here by reference.

**SECTION 2. SUPPORT FOR CONTRACT**

The Village President and Village Board of Trustees are hereby authorized and directed to execute on behalf of the Village of Oswego a professional services contract with Christopher B. Burke Engineering, Ltd., Rosemont, IL, for the performance of a traffic study of Washington Street substantially in the form attached as “Exhibit A.”

**SECTION 3. REPEALER**

All Resolutions or parts of Resolutions in conflict with any of the provisions of this Resolution shall be, and the same hereby repealed.

**SECTION 4. SEVERABILITY**

This Resolution and every provision thereof shall be considered severable. If any section, paragraph, clause or provision of this Resolution is declared by a court of law to be invalid or unconstitutional, the invalidity or unconstitutionality thereof shall not affect the validity of any other provisions of this Resolution.

**SECTION 5. EFFECTIVE DATE**

This Resolution shall be in full force and effect from and after its passage.

**PASSED** by the Board of Trustees of the Village of Oswego, Kendall and Will Counties, Illinois this 18<sup>TH</sup> day of June 2019.

JAMES MARTER	_____	LUIS PEREZ	_____
TERRY OLSON	_____	JUDY SOLLINGER	_____
PAM PARR	_____	BRIAN THOMAS	_____

**APPROVED** by me, Troy Parlier, as President of the Village of Oswego, Kendall and Will Counties, Illinois this 18<sup>th</sup> day of June 2019.

\_\_\_\_\_  
TROY PARLIER, VILLAGE PRESIDENT

\_\_\_\_\_  
Tina Touchette, Village Clerk

STATE OF ILLINOIS     )  
  )  
COUNTY OF KENDALL    )     SS

**CLERK'S CERTIFICATE**  
**(RESOLUTION)**

I, Tina Touchette, the duly qualified and acting Village Clerk of the Village of Oswego, Kendall and Will Counties, Illinois, do hereby certify that I am the keeper of its books and records and that the attached hereto is a true and correct copy of a Resolution entitled:

**RESOLUTION AUTHORIZING THE EXECUTION OF A PROFESSIONAL ENGINEERING SERVICES CONTRACT WITH CHRISTOPHER B. BURKE LTD, ROSEMONT, IL IN THE AMOUNT OF \$94,500.00 FOR A TRAFFIC STUDY OF WASHINGTON STREET**

which Resolution was duly adopted by said Board of Trustees at a meeting held on the 18th day of June 2019, and thereafter approved by the Village President on the 18th day of June 2019.

I do further certify, in my official capacity, that a quorum of said Board of Trustees was present at said meeting and that the Board complied with all requirements of the Illinois Open Meetings Act.

IN WITNESS WHEREOF, I have hereunto set my hand this \_\_\_ day of \_\_\_\_\_ 2019.

\_\_\_\_\_  
Tina Touchette, Village Clerk  
Village of Oswego

(Seal)



## **PROFESSIONAL SERVICES AGREEMENT**

This agreement is made this 18<sup>th</sup> day of June 2019, between and shall be binding upon the Village of Oswego, Kendall and Will Counties, an Illinois Municipal Corporation hereinafter referred to as the "Village" and Christopher B. Burke Engineering, LTD., hereinafter referred to as the "Engineer" and its successors.

The Engineer shall serve as the Village's consultant. This relationship is that of a buyer and seller of professional services and it is understood that the parties have not entered into any joint venture or partnership with the other. The Engineer shall not be considered to be the agent of the Village. The Engineer shall render Engineering services in accordance with generally accepted and currently recognized Engineering practices and principles. The Engineer shall strive to conduct services under this contract in a manner consistent with that level of care and skill ordinarily exercised by members of the profession currently practicing in the same locality under similar conditions as of the date of this contract. Each party shall designate one person to act with authority in its behalf. The person designated shall review and respond promptly to communications received from the other party.

### **PROJECT UNDERSTANDING AND APPROACH**

The Village seeks to improve pedestrian safety and the intersections of Washington Streets (US 34) with Main Street and Harrison Street. In particular, the Village seeks to install traffic signals at these intersections so that pedestrians have clear right-of-way to cross the streets. The corridor within which these signals are located extends approximately from signal at Chicago Road/Madison Street (5 Corners) to Washington Street/IL 31 (by Village Hall).

### **SCOPE OF SERVICES**

#### **Phase 1**

1. Obtain vehicle and pedestrian counts sufficient to complete the study.
2. Working with the Community Development Department, use existing traffic, recognized growth factors such as those determined by CMAP, the Comprehensive Plan and forecasted development in the downtown to project future vehicle and pedestrian counts over a five- and ten-year planning horizons.

3. Prepare signal warrant analysis for each intersection under existing conditions and projected five and ten-year planning horizons.
4. Conduct modeling to determine impacts to corridor. Using traffic visualization software, prepare a video to help residents, public officials, and others understand the impacts.
5. Prepare Engineering concept plans for each intersection in enough detail to:
  - a. Determine feasibility of construction of traffic signals including power sources
  - b. Identify and develop a plan to resolve any ADA impacts at the intersections
6. Identify short term (30-90 days) actions that can be taken to improve pedestrian safety in the corridor.
7. Determine if a signal interconnect system will be required in the corridor that ties in train pre-emption for the crossing between Main and Harrison Streets.
8. Identify long term actions that could be taken to improve pedestrian safety should traffic signals not be approved at these locations.
9. Identify utility impacts for all options.
10. Prepare cost estimates for all options.
11. Identify permit requirements.
12. Conduct up to two public meetings to gather input from residents and the downtown business community. The purpose of the meetings is to gauge public support for alternative improvements for pedestrians that may increase delay for motorists. Exhibits to be presented included concept drawings of the traffic signals, traffic simulation results, and other documents to clearly demonstrate the options and impacts of improvements. Prepare a summary of the meetings and document resident input as preferences for the options.
13. Coordinate the scope of work with IDOT to ensure they will accept the proposed approach. Present a written report as well as meeting with IDOT and Village officials to discuss the results.

## **SECTION II - SUPPLEMENTAL SERVICES**

Normal and customary engineering services do not include service in respect to the following categories of work, which are usually referred to as SUPPLEMENTAL SERVICES. If Client shall so advise Engineer and Engineer shall perform or obtain from others such services, Engineer will be paid on an hourly basis per Exhibit B, at the option of Client. Additional Supplemental Services for the project include, but are not limited to, the following:

- Services due to major changes in general scope of the project.
- Preparation of a topographic survey and Intersection Design Studies.
- Revising studies, reports, and design documents previously approved by the Client



and/or other government agencies.

- Providing for full or part-time construction observation. Construction inspection, supervision, direction or surveillance of the work of the Contractor(s), his employees or agents, will not be provided and we shall not be liable for the results of any such interpretations or decisions rendered in good faith. The Contractor(s) will be informed by the Client that neither the presence of our field staff nor the observation and testing by our firm shall excuse him in any way for defects discovered in the work. We understand that full-time inspection and testing services will be provided by others. It should be understood that we will not be responsible for job and site safety on this project; job and site safety shall be the sole responsibility of the Contractor(s).
- Providing engineering design and construction services for unusual or unanticipated improvements, and for additional off-site improvements requested by the Client, municipality, other government agencies, or necessary to the project development beyond that being included under BASIC SERVICES herein.
- Preparation of PESA and PSI.
- Preparation of any plats or legal descriptions.
- Construction, soils or materials testing.

### **SCHEDULE**

Engineer is prepared to begin work on the Phase I study upon a notice-to-proceed. It is our understanding that the Village would like the preliminary results of the warrant study completed 60 days from the notice-to-proceed. The remaining tasks will be completed as the project progresses through the public meeting efforts and review and approval process with IDOT and the Village.

### **PERSONAL PROTECTIVE EQUIPMENT**

The Engineer shall comply with the Village Personal Protective Equipment (PPE) policy. The policy at minimum requires anyone on a construction site to wear a safety vest and steel-toed shoes. Various situations calling for further safety requirements are indicated in the policy.

### **SUPERVISION OF WORK**

The Engineer shall not at any time supervise, direct, or have control over any contractor's work, nor shall the Engineer have authority over or responsibility for the means, methods, techniques, sequences, or procedures of construction selected or used by any contractor, nor for safety precautions and programs in connection with the contractors' work, nor for any failure of any contractor to comply with laws and regulations applicable to contractor's work. The Engineer

neither guarantees the performance of any contractor nor assumes responsibility for any contractor's failure to furnish and perform its work. The Engineer shall have no authority to stop any contractors' work but will advise Village of work that does not meet approved plans and specifications.

### **DELIVERY AND REUSE OF DOCUMENTS**

All drawings, specifications, reports, and any other project documents prepared by the Engineer in connection with any or all of the services furnished thereunder shall be delivered to the Village for the express use of the Village. The Engineer does have the right to retain original documents but shall cause to be delivered to the Village such quality of documents so as to assure complete reproducibility of the documents delivered. In particular the Village may request, at no additional cost, the delivery of additional sets of drawings or documents if the Engineer fails to deliver a fully reproducible document.

### **SUBLETTING OF CONTRACT**

The Engineer may sublet portions of the work. Sub-consultants shall conform, in all respects, to the applicable provisions specified for the Engineer and shall further be subject to approval by the Village prior to the performance of any work by the sub-consultant. Rejection of a particular sub-consultant shall not be causing to alter the original contract or to request additional compensation. The Engineer shall identify all proposed sub-consultants who will furnish services. The work to be done by the sub-consultant shall be outlined in detail to the Village prior to the start of work and identified in the progress reports submitted by the Engineer. The qualifications of the proposed sub-consultant shall be submitted to the Village, in the same format and basic requirements as required of the Engineer. At all times the Engineer shall maintain no less than fifty-one (51) percent of the dollar value of the contract by direct employees of the Engineer.

### **CONTRACT AMOUNT AND PRICES**

For the Engineer's services described in the contract documents, the Village agrees to pay, and the Engineer agrees to accept as full payment for the services which are the subject matter of this Agreement in accordance with the General Provisions and the "Local Government Prompt Payment Act". Fees shall be as described in Exhibit A - Engineer's Work Effort and Fee.

Unless specifically agreed to by the Village, the following expenses will not be allowed: charges for items that are considered a normal cost of doing business or are considered a normal feature in an office, for example, charges for sending or receiving facsimiles or emails; CADD or computer charges; telephone, pager or other telecommunication charges; copies or reproductions for the internal use of the Engineer (copies or reproductions for external use, i.e. submittals to the Village or other governing agencies, are allowable as reimbursable expenses.)

### **INVOICING AND PAYMENT**

Each project shall be computed and paid in accordance with Exhibit A. In the event that the actual hours exceed the approved estimated hours by more than 10% for tasks outside the general scope of services, the Engineer shall obtain authorization from the Village prior to commencing

any additional work. The Engineer shall submit invoices in duplicate. Invoices will cover the work performed from the first of each month to the end of that specific month. Only one invoice shall be submitted per month. An invoice must be submitted for work done through April 30 of each year as this is the end of the Village's fiscal year. Statements shall include a detailed breakdown of all charges incurred. The invoice shall detail personnel name, title, pay rate, hours charged, and task performed. If personnel worked on more than one task during the invoice period, each task shall be identified with the corresponding hours charged. All direct costs shall be itemized consistent with the various categories stated within the Proposal. Invoices shall be based on actual hours of performance.

Invoices shall be accompanied by progress reports. Invoices submitted without a progress report will be considered incomplete and will not be processed for payment. The following five items shall be clearly addressed in each report as necessary to indicate project status:

1. Work performed in the period covered by the invoice.
2. Work to be performed in the next period.
3. Deliverables and due dates, particularly noting items due in the next period (updated schedule).
4. Items that the Engineer is waiting for from the Village or other agencies.
5. A summary or statement discussing the financial status of the individual work order – is the project under, on, or over budget. If over budget, identify the reason and provide an estimate number of hours and cost to complete the project.

Sub-consultant costs are not considered direct costs for purposes of calculating the withheld amount. Should overruns for any of the items within the Proposal become evident due to unforeseen circumstances beyond the Engineer's control, the Engineer shall notify the Village immediately and no further work shall be done by the Engineer until authorization to proceed in writing has been received from the Village.

### **CHANGES**

The Village reserves the right by written amendment to make changes in requirements, amount of work, or time schedule. The Engineer and the Village shall negotiate appropriate adjustments acceptable to both parties to accommodate any changes.

### **SUSPENSION OF SERVICES**

The Village may, at any time, by written order to the Engineer require the Engineer to stop all, or any part, of the services required by this contract. Upon receipt of such an order the Engineer shall immediately comply with its terms and take all steps to minimize the incurrence of costs allocable to the services covered by the order. The Village will pay for costs associated with suspension provided the Village deems them reasonable.

### **TERMINATION OF CONTRACT**

The Village reserves the right to terminate the whole or any part of any contract awarded based on the use of these short-lists, upon ten (10) calendar days written notice to the Engineer. The Village further reserves the right to cancel the whole or any part of the contract if the Engineer fails to perform any of the provisions in the contract or fails to make delivery within the time

stated. The Engineer will not be liable to perform if situations arise by reason of strikes, acts of God or the public enemy, acts of the Village, fires or floods.

Upon such termination, the Engineer shall cause to be delivered to the Village all surveys, reports, permits, agreements, calculations, drawings, specifications, partially and completed estimates and data, as well as products of computer aided drafting, design and writing that have been paid for by the Village. Costs of termination incurred by the Engineer before the termination date will be reimbursed by the Village only, if prior to the effective termination date, the Village receives from the Engineer a list of actions necessary to accomplish termination and the Village agrees in writing that those actions be taken. Upon receipt of the termination notice the Engineer shall stop all work until said agreement is reached.

## **INSURANCE**

(A) During the term of the contract, the Engineer shall provide the following types of insurance in not less than the specified amounts:

- i. Comprehensive General Liability - \$1,000,000.00 per occurrence;
- ii. Auto Liability - Combined Single Limit Amount of \$1,000,000.00 on any Engineer owned, and/or hired, and/or non-owned motor vehicles engaged in operations within the scope of this contract;
- iii. Workers Compensation - Statutory; Employers Liability \$1,000,000.00 (the policy shall include a 'waiver of subrogation');
- iv. Umbrella Coverage - \$2,000,000.00 (this shall apply to General Liability, Auto Liability and Professional Liability, except if the amount for Professional Liability exceeds these combined limits, then Umbrella Coverage does not need to apply to Professional Liability); and
- v. Professional Liability - \$1,000,000.00.

(B) The Engineer shall furnish to the Village satisfactory proof of coverage of the above insurance requirements, by a reliable company or companies, before commencing any work. Such proof shall consist of certificates executed by the respective insurance companies and filed with the Village. Said certificates shall contain a clause to the effect that, for the duration of the contract, the insurance policy shall be canceled, expire or changed so as to the amount of coverage only after written notification 30 days in advance to the Village. In addition, said certificates shall list the Village and its officers, agents and employees as additional insureds on all required insurance policies except the policy for professional liability.

(C) The Engineer shall require sub-consultants, if any, not protected under the Engineer's policies, to take out and maintain insurance of the same nature in amounts, and under the same terms, as required of the Engineer.

## **INDEMNIFICATION**

The Engineer shall indemnify and save harmless the Village, its officers, agents, employees, representatives and assigns, from lawsuits, actions, costs (including attorneys' fees), claims or liabilities of any character brought because of any injuries or damages received or sustained by any person, persons, or property on account of negligent act or omission or any willful

misconduct of said Engineer, its officers, agents and/or employees arising out of, or in performance of any of the provisions of the contract, including any claims or amounts recovered for any infringements of patent, trademark or copyright; or from any claims or amounts arising or recovered under the "Worker's Compensation Act" or any other law, ordinance, order or decree. In connection with any such claims, lawsuits, actions or liabilities, the Village, its officers, agents, employees, representatives and their assigns shall have the right to defense counsel of their choice. The Engineer shall be solely liable for all costs of their defense and for all expenses, fees, judgments, settlements and all other costs arising out of such claims, lawsuits, actions or liabilities.

### **COMPLIANCE WITH LAWS**

The Engineer shall, at all times, observe and comply with all laws, ordinances and regulations of the Federal, State, and local governments, which may in any manner affect the preparation of proposals or the performance of the contract.

### **COMPLIANCE WITH OSHA STANDARDS**

The Engineer shall comply with all applicable requirements and standards as specified by the Occupational Safety and Health Act for duration of the contract.

### **PERMITS AND LICENSES**

The Engineer shall obtain, at its own expense, all permits and licenses which may be required to complete the contract, and/or are required by municipal, state, and federal regulations and laws.

### **TAXES**

The Village is exempt, by law, from paying the following taxes: Federal Excise Tax, Illinois Retailer's Occupation Tax, Use Tax and Municipal Retailers' Occupation Tax on materials and services purchased by the Village. A copy of the Village tax-exempt letter will be provided to the successful Engineer when requested.

### **NON-DISCRIMINATION**

- a. Engineer shall, as a party to a public contract:
  1. Refrain from unlawful discrimination in employment and undertake affirmative action to assure equality of employment opportunity and eliminate the effects of past discrimination;
  2. By submission of this Proposal, the Engineer certifies that it is an "equal opportunity employer" as defined by Section 2000(e) of Chapter 21, Title 42, U.S. Code Annotated and Executive Orders #11246 and #11375 (42 U.S.C., Section 2000 (e)); Exec. Order No. 11246, 30 F.R. 12319 (1965); Exec. Order No. 11375, 32 F.R. 14303 (1967) which are incorporated herein by reference. The Equal Opportunity Clause, Section 6.1 of the Rules and Regulations of the Department of Human Rights of the State of Illinois, is a material part of any contract awarded on the basis of this Proposal.

- b. It is unlawful to discriminate on the basis of race, color, sex, national origin, ancestry, age, marital status, physical or mental handicap or unfavorable discharge for military service. Engineer shall comply with standards set forth in Title VII of the Civil Rights Act of 1964, 42 U.S.C. S2000 et seq. and The Human Rights Act of the State of Illinois (775 ILCS 5/1 - 101).

**FORCE MAJEURE**

The Village shall not be liable for any fault or delay caused by any contingency beyond their control including but not limited to acts of God, wars, strikes, walkouts, fires, natural calamities, or demands or requirements of other governmental agencies.

**VENUE**

The parties hereto agree that for purposes of any lawsuit(s) between them concerning the contract, its enforcement, or the subject matter thereof, venue shall be in Kendall County, Illinois, and the laws of the State of Illinois shall govern the cause of action.

**CONFLICT OF INTEREST**

The Engineer agrees to not perform professional services during the term of the contract for any person, firm or corporation, for any project or work that may be subject to the Village's review/inspection, to occur or occurring within the corporate limits of the Village, or contiguous to the corporate limits of the Village, without notification to the Village prior to rendering services. The Engineer agrees to provide the Village with written notification whenever the services provided under this agreement shall require the Engineer to review or inspect work performed by any other firm or corporation for whom the Engineer is or has within the previous twelve (12) months provided professional services, or with which any of the Engineer's owners, partners or principals have a financial interest. The Engineer agrees to provide written notification to the Village whenever the Engineer, or any other firm or corporation with which any of the Engineer's owners, partners or principals have a financial interest, performs services or work that may be subject to the Village's review/inspection, or is contiguous to the corporate limits of the Village. The Village may at its discretion disqualify the Engineer from participation as a representative of the Village in such projects or in projects potentially impacted.

**ENGINEER'S CERTIFICATION**

Consultant Engineering Services to the Village, hereby certifies that said Engineer:

- A. Certifies that it is not barred from bidding or contracting with the Village as a result of a violation of either Paragraph 33E-3 (Bid rigging) or 33E-4 (Bid rotating) of Act 5, Chapter 720 of the Illinois Compiled Statutes regarding criminal interference with public contracting, and
- B. Swears under oath that it is not delinquent in the payment of any tax administered by the Illinois Department of Revenue as required by Chapter 65, Act 5, paragraph 11-42.1 of the Illinois Compiled Statutes, and

- C. States that is has a written sexual harassment policy as required by the Illinois Human Rights Act (775 ILCS 5/2-105(A) (4) a copy of which shall be provided to the Village upon request, and
- D. Agrees to comply with the requirements of the Illinois Human Rights Act regarding Equal Employment Opportunities as required by Section 2-105 of the Illinois Human Rights Act (775 ILCS 5/2-105) and agrees to comply with the EQUAL EMPLOYMENT OPPORTUNITY CLAUSE in Appendix A, Section 750, Part 750, Chapter X, Subtitle B of Title 44 of the Illinois Administrative Code incorporated herein by reference, and
- E. Agrees to comply with the civil rights standards set forth in Title VII of the Civil Rights Act as mandated in Executive Order No. 11246, U.S.C.A. Section 2000e n.114 (September 24, 1965), and
- F. Agrees to comply with the Substance Abuse Prevention on Public Works Projects Act (820 ILCS 265/1 et seq.) if this Project is a “public work” within the meaning of the Illinois Prevailing Wage Act (820 ILCS 130/.01 et seq.) and prohibit substance abuse while performing such work and has a substance abuse prevention program, and
- G. Agrees to provide a drug-free workplace pursuant to the Drug-Free Workplace Act (30 ILCS 580/1 et seq.) (25 or more employees under a contract of more than \$5,000 or for individuals only when greater than \$5,000), and
- H. Agrees to comply with the Employment of Illinois Workers on Public Works Act (30 ILCS 570/0.01 et seq.) and employ Illinois laborers if at the time of this contract is executed or if during the term of this contract there is excessive unemployment in Illinois as defined in the Act.

IN WITNESS WHEREOF the parties hereto have executed or caused to be executed by their duly authorized agents, this contract of which shall be deemed original, on the day and year first written.

---

Village of Oswego Representative Date

---

Attest Title

Christopher B. Burke 847-823-0500

---

(Printed Name of Engineer) Phone Number

9575 W. Higgins Road, Suite 600 Rosemont, IL 60018

Address City, State, Zip Code



---

Signature of Authorized Representative

President June 10, 2019

---

Title Date



**EXHIBIT A: PROPOSED FEE**

The proposed Scope of Services will be invoiced on a Time & Material basis using the rate schedule below not to exceed the estimated total below of \$94,500.00.

<b>Task Description</b>	<b>Hours</b>	<b>Cost</b>
Task 1 – Meetings and Coordination	150	\$18,000.00
Task 2 – Data Collection and Field Observations	28	\$7,500.00
Task 3 – Traffic Signal Warrant Analysis	80	\$10,000.00
Task 4 – Crash Analysis	74	\$8,000.00
Task 5 – Railroad Report	80	\$10,000.00
Task 6 – Traffic/Capacity Analysis	60	\$8,000.00
Task 7 – Improvement Concepts and Cost Estimates	70	\$10,000.00
Task 8 – Project Report	95	\$12,000.00
Task 9 – Project Management and QC/QA	38	\$6,000.00
Task 10 – Direct Costs (*)	-	\$5,000.00
<b>TOTAL</b>	<b>657</b>	<b>\$94,500.00</b>

\*Direct costs include expenses for traffic counting, mileage/toll reimbursement and prints/copies for external use.

<b>Position</b>	<b>Hourly Rate</b>
Engineer VI	\$70.00
Engineer IV	\$54.41
Engineer III	\$46.70
Engineer I/II	\$33.08
Engineering Technician IV	\$48.25
CAD Technician II	\$46.92
Landscape Architect	\$55.50

**EXHIBIT B: RATE SCHEDULE**

**CHRISTOPHER B. BURKE ENGINEERING, LTD.**  
**STANDARD CHARGES FOR PROFESSIONAL SERVICES**  
**JANUARY, 2019**

<u>Personnel</u>	<u>Charges*</u> <u>(\$/Hr)</u>
Principal	265
Engineer VI	241
Engineer V	200
Engineer IV	163
Engineer III	146
Engineer I/II	116
Survey V	220
Survey IV	188
Survey III	165
Survey II	121
Survey I	96
Engineering Technician V	190
Engineering Technician IV	155
Engineering Technician III	140
Engineering Technician I/II	65
CAD Manager	170
Assistant CAD Manager	147
CAD II	130
GIS Specialist III	142
GIS Specialist I/II	90
Landscape Architect	163
Environmental Resource Specialist V	208
Environmental Resource Specialist IV	163
Environmental Resource Specialist III	134
Environmental Resource Specialist I/II	90
Environmental Resource Technician	110
Administrative	100
Engineering Intern	61
Information Technician III	125
Information Technician I/II	112
<u>Direct Costs</u>	
Outside Copies, Blueprints, Messenger, Delivery Services, Mileage	Cost + 12%

\*Charges include overhead and profit

Christopher B. Burke Engineering, Ltd. reserves the right to increase these rates and costs by 5% after December 31, 2019.

**AGENDA ITEM**

**MEETING TYPE:** Village Board  
**MEETING DATE:** June 18, 2019  
**SUBJECT:** Staffing Changes

**ACTION REQUESTED:**  
 Approval of a Resolution Modifying Authorized Staffing Levels

**BOARD/COMMISSION REVIEW:**  
 NA

**ACTION PREVIOUSLY TAKEN:**

Date of Action	Meeting Type	Action Taken
NA	NA	NA

**DEPARTMENT:** Human Resource  
**SUBMITTED BY:** Christina Burns, Assistant Village Administrator; Jeff Burgner, Police Chief

**FISCAL IMPACT:**  
 Administrative Assistant: Total cost savings between \$11,178.77 and \$14,167.04.  
 Sergeant: Cost increase totaling FY20 - \$3,198, FY21 – \$12,342 & FY22 – \$15,209, based on difference between a patrol officer and sergeant salary.

**BACKGROUND:**  
 Staff regularly evaluates the best way to allocate staff to meet Village needs. The adopted FY2020 Budget outlines the personnel allocations for each department. Staff is requesting a modification of staffing levels in the Police, Administration and Building and Zoning departments to meet evolving needs.

**DISCUSSION:**  
Administrative support staff  
 The Village recently conducted a staffing analysis that prioritized the most effective ways to grow Village staff to meet increasing demands. Additional administrative support ranked high on the list, with each Department in Village Hall in need of additional administrative help. A full-

time Administrative Assistant in the FY 2020 Corporate budget to address these needs, with the intention of further defining the role prior to hiring the position.

Economic Development, Community Development/Building & Zoning, the Clerk’s Office and Finance all indicated a need for additional administrative support. Tasks included answering calls, greeting walk-up counter visitors, processing payments or permits, maintaining electronic and physical files, and assisting with scheduling. Additionally, a vacancy in the Executive Assistant position provides the opportunity to review how responsibilities are allocated more broadly. Previously, the Executive Assistant provided support for the Village Board, Village Administrator and Village Clerk.

After thorough discussion, staff is recommending hiring three part-time Administrative Assistants in lieu of a full-time position. Two positions would be assigned to Building and Zoning to assist with permitting, filing and assisting customers at the counter. Building and Zoning would also take over the Special Events permitting process that is currently shared between the Village Clerk and Finance Department. The third position would be assigned to the Village Clerk to provided support previously provided by the Executive Assistant. Finally, the Executive Assistant would be assigned to support the Village Board, Administrator and Economic Development Director.

A full-time Administrative Assistant, inclusive of taxes, benefits and pension, has a total cost between \$74,500 and \$96,800 based on salary and benefit selections. The three part-time positions total between \$60,300 and \$85,600 due to the elimination of benefit and pension costs. Staff is recommending assigning this position to Grade II (between \$18.68 and \$26.52 per hour) based on comparable wages for part-time administrative support positions in other communities.

Administrative Assistant Cost Comparison

	Min	Max
Full time/hr	\$ 21.70	\$ 30.82
Wage	\$ 45,136.00	\$ 64,105.60
Benefits	\$ 29,358.10	\$ 32,719.51
Total Cost	\$ 74,494.10	\$ 96,825.11
Part time/hr	\$ 18.68	\$ 26.52
Wage	\$ 18,680.00	\$ 26,520.00
Benefits	\$ 1,429.02	\$ 2,028.78
Total Cost x3	\$ 60,327.06	\$ 85,646.34
Savings	\$ 14,167.04	\$ 11,178.77

Police Department staffing

The Village budget includes authorization for 49 sworn officers. Of those, four serve as department command, eight are allocated to sergeant and 37 as patrol officers. Staff is requesting

promoting an officer to the rank of sergeant to serve as the sergeant of the Criminal Intelligence Team (CIT) which is an arm of the Kendall County Cooperative Police Assistant (KCCPAT). CIT is a multi-jurisdictional task force that focuses on gang, gun and drug related investigations and offenses throughout Kendall County. It was established in May 2015 and comprises officers from Oswego, Kendall County Sheriff's Office, Yorkville Police Department, and Montgomery Police Department. CIT provides the Village with a team of officers that specialize in gang related crimes in an effort to minimize violent crimes from occurring in the Village. The team works closely with other Chicagoland gang units to share critical gang related intelligence. The team of four serves as a force multiplier regarding enforcement efforts to member agencies when issues arise that relate to gang, gun and drug related criminal activity.

The CIT has had a rotation of sergeants from the member agencies to lead the team. The most recent CIT Sergeant was promoted to a Deputy Chief position in Yorkville. It is now Oswego's turn to supply a sergeant. By assigning a Sergeant, Oswego will have a Patrol Officer return from KCCPAT to the general patrol staff in the operations of the Department.

Promoting a Patrol Officer to Sergeant will minimize the risk for overtime at the sergeant's level on patrol shifts and not cause an increased risk of overtime at the patrol rank. We will not need to hire another Patrol Officer to fill the vacancy from the promotion since we will have the Patrol Officer from KCCPAT returning to patrol. The assignment of a Sergeant to CIT is not planned to last more than five years. It would be expected that another member agency would step up and provide the next supervisor for a similar term in CIT. Once our Department completes our obligation, this member would return to the Department and be reintroduced to our staffing plan through the potential of adding a Commander position that would be appointed in accordance to Village Code. If the Department was not able to grow the command staff team at that time, we would look for other options to absorb that role.

The overall sworn level in the Department is currently 49 and would remain at that level even with the proposed promotion. The staffing costs to be considered would be the difference between a Patrol Officer and a Sergeant salary. Typically, any overtime worked in the CIT is reimbursed through Federal funding and would be a passthrough for the Village, therefore our risk would be minimal from an overtime perspective. If authorized, this promotion would take place in January of 2020 which would assist in controlling cost rather than promote immediately. The proposed revised Police Department organization chart is attached.

**3 Year Salary Comparison  
Collective Bargaining Agreements Expire April 30, 2022**

	Difference
FY20 (Jan 1 <sup>st</sup> – April 30 <sup>th</sup> )	\$3,198
FY21	\$12,342
FY22	\$15,209

**RECOMMENDATION:**

1. Approval of a Resolution Modifying Authorized Staffing Allocation in the FY2020 Budget and
2. Approval of a Resolution Adopting a Revised Salary Schedule for FY2020 (Part-time Administrative Assistant)

**ATTACHMENTS:**

- Proposed Police Department Organization Chart
- A Resolution Modifying Staffing Allocation in the FY2020 Budget
- A Resolution Adopting a Revised Salary Schedule for Fiscal Year 2020
  - Exhibit A: Revised Salary Schedule for Fiscal Year 2020

**VILLAGE OF OSWEGO - Salary Ranges**  
Fiscal Year 2020

<u>Position</u>	<u>Min.</u>	<u>Mid.</u>	<u>Max.</u>	
<u>Grade 0</u>	\$ 20,520.11	\$ 24,829.34	\$ 29,138.56	
Police Cadet	\$ 1,710.01	\$ 2,069.11	\$ 2,428.21	Monthly Salary
Public Works Seasonal Intern (Undergraduate)	\$ 9.87	\$ 11.94	\$ 14.01	Hourly Rate
<u>Grade I</u>	\$ 29,612.21	\$ 35,830.78	\$ 42,049.34	
Community Service Officer	\$ 2,467.68	\$ 2,742.56	\$ 3,134.35	Monthly Salary
Graduate Student Intern	\$ 14.24	\$ 17.23	\$ 20.22	Hourly Rate
Part-time Records Clerk				
<u>Grade II</u>	\$ 38,844.23	\$ 47,001.52	\$ 55,158.81	
Part-time Administrative Assistant	\$ 3,237.02	\$ 3,916.79	\$ 4,596.57	Monthly Salary
	\$ 18.68	\$ 22.60	\$ 26.52	Hourly Rate
<u>Grade III</u>	\$ 41,994.78	\$ 50,813.68	\$ 59,632.58	
Records Clerk	\$ 3,499.56	\$ 4,234.47	\$ 4,969.38	Monthly Salary
	\$ 20.19	\$ 24.43	\$ 28.67	Hourly Rate
<u>Grade IV</u>	\$ 45,144.39	\$ 54,624.71	\$ 64,105.03	
Administrative Assistant	\$ 3,762.03	\$ 4,552.06	\$ 5,342.09	Monthly Salary
	\$ 21.70	\$ 26.26	\$ 30.82	Hourly Rate
<u>Grade V</u>	\$ 48,530.20	\$ 58,721.55	\$ 68,912.89	
Deputy Village Clerk	\$ 4,044.18	\$ 4,893.46	\$ 5,742.74	Monthly Salary
Utility Billing Coordinator	\$ 23.33	\$ 28.23	\$ 33.13	Hourly Rate
B&Z Assistant				
Finance Assistant				
<u>Grade VI</u>	\$ 52,169.98	\$ 63,125.67	\$ 74,081.37	
Code Enforcement Officer	\$ 4,347.50	\$ 5,260.47	\$ 6,173.45	Monthly Salary
Executive Assistant	\$ 25.08	\$ 30.35	\$ 35.62	Hourly Rate
Accreditation Manager				
Evidence Custodian				
<u>Grade VII</u>	\$ 60,288.93	\$ 72,949.60	\$ 85,610.28	
Human Resource Generalist	\$ 5,024.08	\$ 6,079.13	\$ 7,134.19	Monthly Salary
Plumbing Inspector	\$ 28.99	\$ 35.07	\$ 41.16	Hourly Rate
Staff Accountant				
Building Inspector				
Community Engagement Coordinator				
<u>Grade VIII</u>	\$ 64,810.60	\$ 78,420.82	\$ 92,031.05	
Chief Building Inspector	\$ 5,400.88	\$ 6,535.07	\$ 7,669.25	Monthly Salary
Planner	\$ 31.16	\$ 37.70	\$ 44.25	Hourly Rate
Chief Infrastructure Inspector				
<u>Grade IX</u>	\$ 67,748.68	\$ 81,975.90	\$ 96,203.13	
Village Clerk	\$ 5,645.72	\$ 6,831.33	\$ 8,016.93	Monthly Salary
Records Supervisor				
Purchasing Manager				
Facilities Manager				
Project Engineer				
<u>Grade X</u>	\$ 75,878.52	\$ 94,848.15	\$ 113,817.78	
Assistant Public Works Director	\$ 6,323.21	\$ 7,904.01	\$ 9,484.81	Monthly Salary
IT/GIS Manager				
<u>Grade XI</u>	\$ 84,983.94	\$ 106,229.93	\$ 127,475.91	
Building and Zoning Manager	\$ 7,082.00	\$ 8,852.49	\$ 10,622.99	Monthly Salary
Assistant Finance Director				
Police Commander				
<u>Grade XII</u>	\$ 95,182.01	\$ 118,977.51	\$ 142,773.01	
Deputy Chief	\$ 7,931.83	\$ 9,914.79	\$ 11,897.75	Monthly Salary
Assistant Village Administrator				
Economic Development Director				

<u>Grade XIII</u>	\$ 106,603.84	\$ 133,254.81	\$ 159,905.77	
Community Development Director	\$ 8,883.65	\$ 11,104.57	\$ 13,325.48	Monthly Salary
Finance Director				
Public Works Director				
Police Chief				
<u>Grade XIV</u>	\$ 119,396.32	\$ 149,245.40	\$ 179,094.48	
Vacant	\$ 9,949.69	\$ 12,437.12	\$ 14,924.54	Monthly Salary
<u>Grade XV</u>	\$ 133,723.87	\$ 167,154.84	\$ 200,585.81	
Village Administrator (see agreement)	\$ 11,143.66	\$ 13,929.57	\$ 16,715.48	Monthly Salary
<u>Represented Employees:</u>	<u>Min</u>	<u>Max</u>	<u>No. Steps</u>	
Technician (5/1/2019 to 4/30/2020)	\$ 44,805.00	\$ 61,764.19	13	
Mechanic (5/1/2019 to 4/30/2020)	\$ 51,500.00	\$ 70,993.32	13	
Supervisor (5/1/2019 to 4/30/2020)	\$ 55,620.00	\$ 76,672.78	13	
Superintendent (5/1/2019 to 4/30/2020)	\$ 61,800.00	\$ 85,191.98	13	
Police Officer (5/1/2019 to 4/30/2020)	\$ 61,183.73	\$ 96,051.24	9	
Sergeant (5/1/2019 to 4/30/2020)	\$ 105,647.64	\$ 110,456.79	3	

\*Local 150, MAP and Sergeants Agreements expire April 30, 2022



# Oswego Police Organization Chart

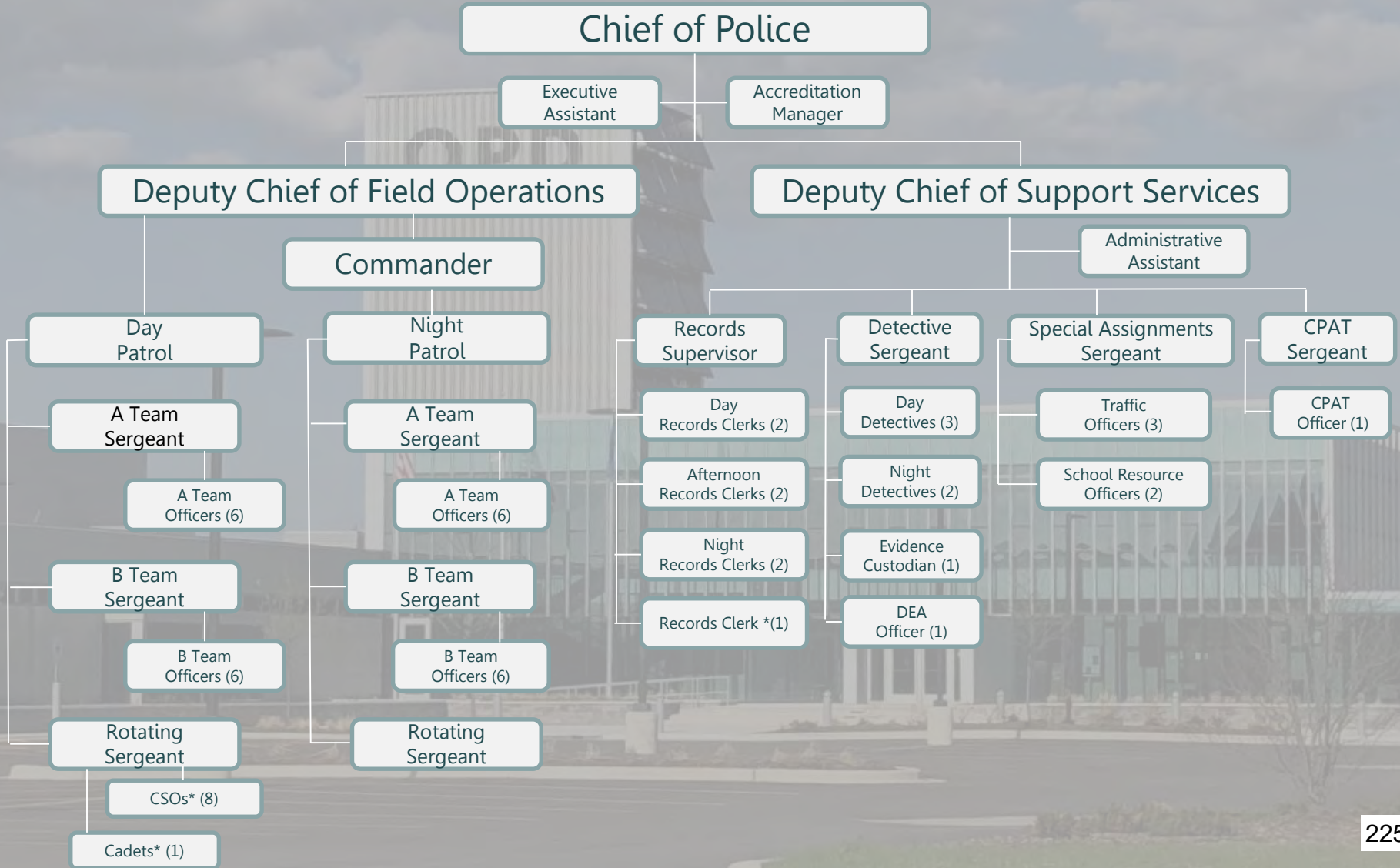

\*Part-Time

**RESOLUTION NO. 19 - R - \_\_\_\_**

---

**A Resolution Modifying Authorized  
Staffing from the FY2020 Budget  
(Part-time Administrative Assistant and Sergeant)**

---

**WHEREAS**, the Village of Oswego (“Village”) has a population of more than 25,000 and is therefore a “Home Rule Unit” under the 1970 Illinois Constitution; and

**WHEREAS**, the Illinois Constitution of 1970 provides that a Home Rule Unit may exercise any power and perform any function pertaining to its government and affairs, including but not limited to the power to regulate for the protection of the public health, safety, morals and welfare; to license, to tax; and to incur debt; and

**WHEREAS**, the Village of Oswego Fiscal Year 2020 Budget includes a new position of full-time Administrative Assistant to meet growing administrative support needs within the Village; and

**WHEREAS**, the Village’s needs can best be met by the hiring of three part-time Administrative Assistants; and

**WHEREAS**, the Village of Oswego Fiscal Year 2020 Budget includes funding for eight Sergeants and thirty-seven Patrol Officers; and

**WHEREAS**, the Village of Oswego desires to support the Criminal Intelligence Team which is an arm of the Kendall County Cooperative Police Assistant Team with the allocation of a sergeant to provide leadership to the team; and

**WHEREAS**, it is in the best interest of the Village of Oswego to hire three part-time Administrative Assistants and promote an additional Sergeant.

**NOW, THEREFORE, BE IT RESOLVED BY THE PRESIDENT AND BOARD OF TRUSTEES OF THE VILLAGE OF OSWEGO, KENDALL AND WILL COUNTIES, ILLINOIS,** as follows:

**SECTION 1. INCORPORATION OF RECITALS**

That the recitals set forth above are incorporated here by reference.

**SECTION 2. SUPPORT FOR STAFFING CHANGE**

The Village President and Village Board of Trustees hereby authorize the Village Administrator to hire three part-time administrative assistants, and the Board of Police Commissioners to appoint a ninth sergeant, maintaining the forty-nine sworn officers within the department.

**SECTION 3. REPEALER**

All Resolutions or parts of Resolutions in conflict with any of the provisions of this Resolution shall be, and the same hereby repealed to the extent of the conflict.

**SECTION 4. SEVERABILITY**

This Resolution and every provision thereof shall be considered severable. If any section, paragraph, clause or provision of this Resolution is declared by a court of law to be invalid or unconstitutional, the invalidity or unconstitutionality thereof shall not affect the validity of any other provisions of this Resolution.

**SECTION 5. EFFECTIVE DATE**

This Resolution shall be in full force and effect from and after its passage.

**PASSED** by the Board of Trustees of the Village of Oswego, Kendall and Will Counties, Illinois this \_\_\_ day of \_\_\_ 2019.

JAMES MARTER	_____	LUIS PEREZ	_____
TERRY OLSON	_____	JUDY SOLLINGER	_____
PAM PARR	_____	BRIAN THOMAS	_____

**APPROVED** by me, Troy Parlier, as President of the Village of Oswego, Kendall and Will Counties, Illinois this \_\_\_ day of \_\_\_ 2019.

\_\_\_\_\_  
TROY PARLIER, VILLAGE PRESIDENT

\_\_\_\_\_  
Tina Touchette, Village Clerk

STATE OF ILLINOIS     )  
                                  )  
COUNTY OF KENDALL    )     SS

**CLERK'S CERTIFICATE**  
**(RESOLUTION)**

I, Tina Touchette, the duly qualified and acting Village Clerk of the Village of Oswego, Kendall and Will Counties, Illinois, do hereby certify that I am the keeper of its books and records and that the attached hereto is a true and correct copy of a Resolution entitled:

**A Resolution Modifying Authorized  
Staffing from the FY2020 Budget  
(Administrative Assistant and Sergeant)**

which Resolution was duly adopted by said Board of Trustees at a meeting held on the \_\_\_ day of \_\_\_\_\_ 2019, and thereafter approved by the Village President on the \_\_\_ day of \_\_\_\_\_ 2019.

I do further certify, in my official capacity, that a quorum of said Board of Trustees was present at said meeting and that the Board complied with all requirements of the Illinois Open Meetings Act.

IN WITNESS WHEREOF, I have hereunto set my hand this \_\_\_ day of \_\_\_\_\_ 2019.

\_\_\_\_\_  
Tina Touchette, Village Clerk  
Village of Oswego

(Seal)

**RESOLUTION NO. 19 - R - \_\_\_\_**

---

**A Resolution Adopting Revised  
Fiscal Year 2020 Salary Ranges  
(Part-Time Administrative Assistant)**

---

**WHEREAS**, the Village of Oswego (“Village”) has a population of more than 25,000 and is therefore a “Home Rule Unit” under the 1970 Illinois Constitution; and

**WHEREAS**, the Illinois Constitution of 1970 provides that a Home Rule Unit may exercise any power and perform any function pertaining to its government and affairs, including but not limited to the power to regulate for the protection of the public health, safety, morals and welfare; to license, to tax; and to incur debt; and

**WHEREAS**, the Village of Oswego intends to create a new position of part-time Administrative Assistant; and

**WHEREAS**, it is in the best interest of the Village of Oswego to maintain salary ranges for the purpose of transparent employee compensation.

**NOW, THEREFORE, BE IT RESOLVED BY THE PRESIDENT AND BOARD OF TRUSTEES OF THE VILLAGE OF OSWEGO, KENDALL AND WILL COUNTIES, ILLINOIS,** as follows:

**SECTION 1. INCORPORATION OF RECITALS**

That the recitals set forth above are incorporated here by reference.

**SECTION 2. SUPPORT FOR SALARY RANGES**

The Village President and Village Board of Trustees hereby adopt the Fiscal Year 2020 Salary Ranges as stated in Exhibit A.

**SECTION 3. REPEALER**

All Resolutions or parts of Resolutions in conflict with any of the provisions of this Resolution shall be, and the same hereby repealed to the extent of the conflict.

**SECTION 4. SEVERABILITY**

This Resolution and every provision thereof shall be considered severable. If any section, paragraph, clause or provision of this Resolution is declared by a court of law to be invalid or unconstitutional, the invalidity or unconstitutionality thereof shall not affect the validity of any other provisions of this Resolution.

**SECTION 5. EFFECTIVE DATE**

This Resolution shall be in full force and effect from and after its passage.

**PASSED** by the Board of Trustees of the Village of Oswego, Kendall and Will Counties, Illinois this \_\_\_ day of \_\_\_ 2019.

JAMES MARTER	_____	LUIS PEREZ	_____
TERRY OLSON	_____	JUDY SOLLINGER	_____
PAM PARR	_____	BRIAN THOMAS	_____

**APPROVED** by me, Troy Parlier, as President of the Village of Oswego, Kendall and Will Counties, Illinois this \_\_\_ day of \_\_\_ 2019.

\_\_\_\_\_  
TROY PARLIER, VILLAGE PRESIDENT

\_\_\_\_\_  
Tina Touchette, Village Clerk

STATE OF ILLINOIS     )  
  )  
COUNTY OF KENDALL    )           SS

**CLERK'S CERTIFICATE**  
**(RESOLUTION)**

I, Tina Touchette, the duly qualified and acting Village Clerk of the Village of Oswego, Kendall and Will Counties, Illinois, do hereby certify that I am the keeper of its books and records and that the attached hereto is a true and correct copy of a Resolution entitled:

**A Resolution Adopting Revised  
Fiscal Year 2020 Salary Ranges  
(Part- Time Administrative Assistant)**

which Resolution was duly adopted by said Board of Trustees at a meeting held on the \_\_\_ day of \_\_\_\_\_ 2019, and thereafter approved by the Village President on the \_\_\_ day of \_\_\_\_\_ 2019.

I do further certify, in my official capacity, that a quorum of said Board of Trustees was present at said meeting and that the Board complied with all requirements of the Illinois Open Meetings Act.

IN WITNESS WHEREOF, I have hereunto set my hand this \_\_\_ day of \_\_\_\_\_ 2019.

\_\_\_\_\_  
Tina Touchette, Village Clerk  
Village of Oswego

(Seal)

## CALENDAR UPDATE

### July 4- Village Office Closed

#### **Location: Oswego Village Hall, 100 Parkers Mill, Oswego, IL**

Historic Preservation Commission Meeting	June 26, 2019	7:00 p.m.
Cultural Arts Commission Meeting	July 10, 2019	6:00 p.m.
Planning and Zoning Commission Meeting	July 11, 2019	7:00 p.m.
Committee of the Whole Meeting	July 16, 2019	6:00 p.m.
Regular Village Board Meeting	July 16, 2019	7:00 p.m.
Economic Development Commission	August 7, 2019	6:00 p.m.

#### **Location: Oswego Public Works Facility, 100 Theodore Drive, Oswego, IL**

#### **Location: Oswego Police Department, 3355 Woolley Road, Oswego, IL**

Administrative Adjudication	June 27, 2019	5:00 p.m.
Police Commission Meeting	July 11, 2019	5:00 p.m.
Police Pension Board Meeting	July 25, 2019	3:15 p.m.